

# OFFSET AGRICULTURAL DISKS

**DH5108-DH5110**

**DH5112-DH5114-DH5116**



## Introduction

READ THIS MANUAL carefully to learn how to operate and service your machine correctly. Failure to do so could result in personal injury or equipment damage. This manual and safety signs on your machine may be ordered from your John Deere dealer.

THIS MANUAL SHOULD BE CONSIDERED a permanent part of your machine and should remain with the machine when you sell it.

MEASUREMENTS in this manual are given in customary U.S. units. Only use the correct replacement parts and fasteners.

RIGHT-HAND AND LEFT-HAND sides are determined by facing in the direction the implement will travel when going forward.

WRITE DOWN PRODUCT IDENTIFICATION NUMBERS. Accurately record all the numbers to help in tracing the machine should it be stolen. Your John Deere dealer also needs these numbers when you order parts. File the identification numbers in a secure place away from the machine.

WARRANTY coverage is provided by John Deere according to the terms of the Construction, Utility, and Forestry Products Standard Warranty Statement. Carefully read the warranty statement on the back of your original purchase order for details on coverage and limitations of this warranty.

This warranty provides you the assurance that Frontier will back its products where defects appear within the warranty period. In some circumstances, Frontier also provides field improvements, often without charge to the customer, even if the product is out of warranty. Should the equipment be abused or modified to change its performance beyond the original factory specifications, or if the equipment is used for a purpose other than that which it was designed for, the warranty will become void and field improvements may be denied.

THE TIRE MANUFACTURERS warranty is separate and apart from the equipment warranty and may not apply outside the U.S.

# Contents

Introduction	1
General Arrangement – Models DH5108 / DH5110 / DH5112	4
General Arrangement – Models DH5114 / DH5116	5
General Information	6
Pre-Delivery Checklist	7
Delivery Checklist	7
After Sale Checklist	8
Daily Checklist	8
Seasonal Checklist	8
Decal Identification and Placement	9
Safety First	10
Attaching the Disc to the Tractor	11
Transporting the Disc	11
Adjusting the Transport Levelling Control Arm	12
Transport and Operating Safety	13
Operating the Disk	
General Operating Guidelines	14
Reposition the Hitch	14
Change the Gang Angles	15
Adjust the Levelling Control Arm	16
Service and Maintenance Safety	17
Lubricate the Disk	18
Check the Oil-Bath Bearings	19
Adjusting the Scrapers	19
Repack and Pre-Load Wheel Hub Bearings	20
Fluid and Fastener Specifications	
Disc Gang Assembly Axles	21
Fastener Torque Values	21
Oil-Bath Bearing Oil	21
Tire and Wheel Service	21
Keep Gang Assemblies Tight	22
Assembly Safety	23
Assemble the Disk	24
Disk Gang Assembly Procedure	32
Detailed Parts Diagrams	33
Hitch and Bridle Assembly (Models DH5108 / DH5110 / DH5112)	34
Hitch and Bridle Assembly (Models DH5114 / DH5116)	35
Frame and Transport Assembly (Models DH5108 / DH5110 / DH5112)	36
Frame and Transport Assembly (Models DH5114 / DH5116)	37
Control Arm Assembly (Models DH5108 / DH5110 / DH5112)	38
Control Arm Assembly (Models DH5114 / DH5116)	39
Gang Bars and Scrapers	40

Gang Assembly (1.625 Axle)	41
Gang Assembly (2.125 Axle)	42
Oil-Bath Bearing Assembly (1.625 Axle)	43
Oil-Bath Bearing Assembly (2.125 Axle)	44
Hydraulic Cylinder (CTD)	45
Hydraulic Cylinder (RAM)	46
Disc Blades	47
6-Bolt Hub	48
Tire and Wheel Assembly	49
Light Kit	50
Decals, Reflectors and Logos	51
Specifications	52
Storage	53

# PRODUCT GENERAL ARRANGEMENT AND IDENTIFICATION MODELS DH5108 / DH5110 / DH5112

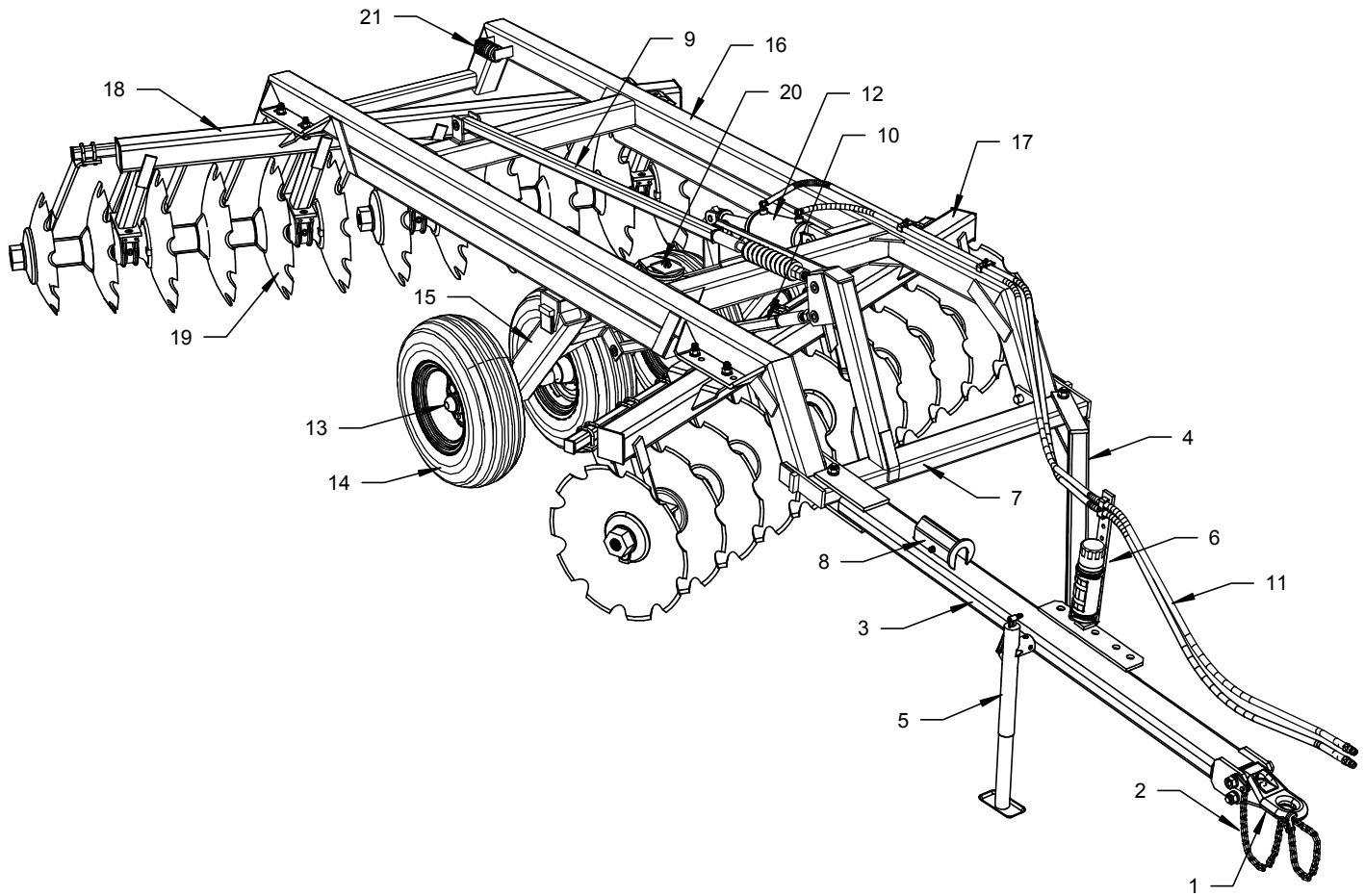

- |    |                                   |    |                                |
|----|-----------------------------------|----|--------------------------------|
| 1  | Hitch Tongue                      | 11 | Hydraulic Hose Kit             |
| 2  | Safety Chain                      | 12 | Hydraulic Cylinder             |
| 3  | Hitch                             | 13 | Hub Assembly                   |
| 4  | Side Arm                          | 14 | Tire and Wheel Assembly        |
| 5  | Jack                              | 15 | Transport Assembly             |
| 6  | Hose Holder & Manual Cannister    | 16 | Main Frame                     |
| 7  | Bridle                            | 17 | Front Gang Bar c/w Scraper Bar |
| 8  | Transport Stay (Storage Location) | 18 | Rear Gang Bar c/w Scraper Bar  |
| 9  | Transport Control Arm             | 19 | Disc Gang Assembly             |
| 10 | Leveling Control Arm              | 20 | Gang Wrenches                  |
|    |                                   | 21 | Depth Control Segments         |

# PRODUCT GENERAL ARRANGEMENT AND IDENTIFICATION MODELS DH5114 / DH5116

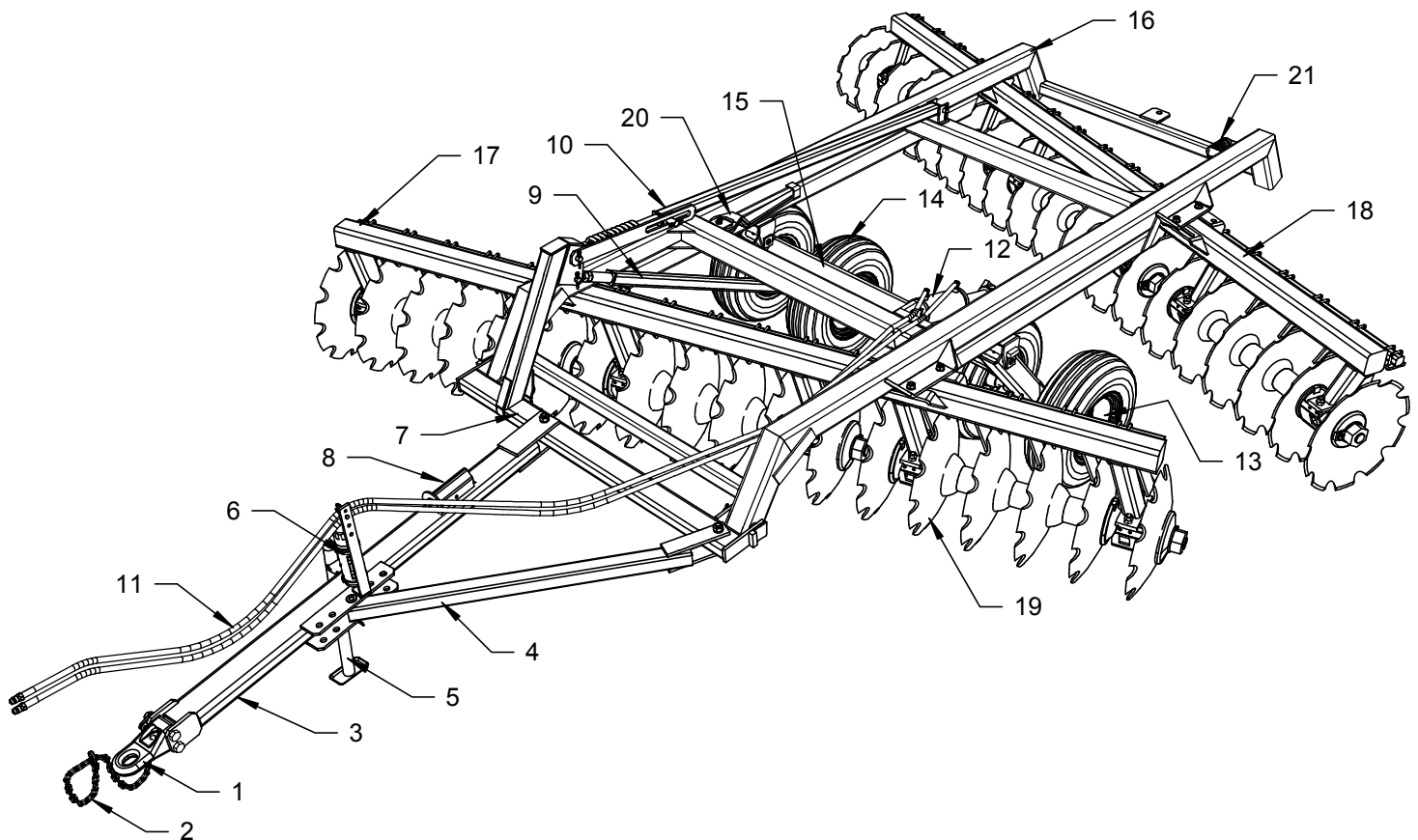

- |                                     |                                   |
|-------------------------------------|-----------------------------------|
| 1 Hitch Tongue                      | 11 Hydraulic Hose Kit             |
| 2 Safety Chain                      | 12 Hydraulic Cylinder             |
| 3 Hitch                             | 13 Hub Assembly                   |
| 4 Side Arm                          | 14 Tire and Wheel Assembly        |
| 5 Jack                              | 15 Transport Assembly             |
| 6 Hose Holder & Manual Cannister    | 16 Main Frame                     |
| 7 Bridle                            | 17 Front Gang Bar c/w Scraper Bar |
| 8 Transport Stay (Storage Location) | 18 Rear Gang Bar c/w Scraper Bar  |
| 9 Transport Control Arm             | 19 Disc Gang Assembly             |
| 10 Leveling Control Arm             | 20 Gang Wrenches                  |
|                                     | 21 Depth Control Segments         |

# General Information

## TO THE DEALER

Assembly and delivery of this product is the responsibility of the John Deere dealer. Read manual instructions and safety rules. Make sure all items on the Dealers Pre-Delivery and Delivery Checklists in the Operators Manual are completed before releasing the equipment to the owner.

## TO THE OWNER

Read this manual before operating your Frontier equipment. The information presented will prepare you to do a better job. Keep this manual handy for ready reference. Require all operators read this manual carefully and become acquainted with all the adjustment and operating procedures before using the equipment. Replacement manuals can be obtained from your selling dealer.

The equipment you have purchased has been carefully engineered and manufactured to provide dependable and satisfactory use. Like all mechanical products, it requires cleaning and upkeep. Lubricate the unit as specified. Many of the features of this equipment necessary for it to perform its intended task are inherently dangerous, so please observe all safety information in this manual and safety decals on the equipment.

For service, your authorized John Deere dealer has trained mechanics, genuine original manufacturer service parts and the necessary tools and equipment to handle your needs.

Use only genuine original manufacturer service parts. Substitute parts will void the warranty and may not meet standards required for safe and satisfactory operation. Record the model number and serial number of your equipment in the spaces provided.

**Date of Purchase** \_\_\_\_\_

**Model** \_\_\_\_\_

**Serial Number (13 or 17 Characters)** \_\_\_\_\_

Provide this information to your dealer to make a warranty claim or obtain correct repair parts.

# Checklists

**PREDELIVERY CHECKLIST:** After the disk has been completely assembled and lubricated, inspect it before delivery to the customer to ensure proper operation. Check off each item of inspection in the list as it is found satisfactory.

- The disk has been assembled according to instructions and all nuts and bolts are present and tight.
- All grease fittings are installed and the disk has been lubricated.
- Tires are properly inflated and wheel lug nuts are present and properly torqued.
- Disk gangs rotate freely without dragging on scrapers.
- Check all pins to make sure retaining hardware is in place.
- Touch-up paint damage due to shipping and assembly.
- Connect disk to tractor drawbar, connect hydraulic hoses and check the hydraulic system for leaks and proper operation of the hydraulic cylinder.
- Safety chain is attached. SMV sign is installed and visible from the rear of disk.
- Light Kit is installed and operating correctly. All safety decals are present and legible.
- This disk has been checked and to the best of my knowledge, is ready for delivery to the customer.

**Set-Up Date** \_\_\_\_\_ **Signature of Assembly Person** \_\_\_\_\_

**DELIVERY CHECKLIST:** The following list is a reminder of important information that should be conveyed directly to the customer upon delivery of the disk. Check off each item as it is fully explained.

- Advise customer the life expectancy and performance of this, like any other machine, is dependent on regular lubrication and maintenance as described in this manual.
- Explain the importance of safe and proper operation of the machine. Point out decals warning the operator of the dangers of unsafe operation procedures and conditions.
- The customer has been told to keep all bolts tight.
- When the disk is transported on road or highway at night or during the day, accessory lights and devices should be used for adequate warning to operators of other vehicles. Replacement safety lights and safety devices are available from your John Deere dealer. In this regard, suggest customers check their local governmental regulations.
- Insure completion of the Delivery and Warranty Registration forms, listing the Serial Number of the machine.
- Explain the Warranty
- Show the customer how to hitch the machine and operate the controls relating to the machine.
- Explain the adjustments for proper operation of the disk.
- Advise use of the safety chain.
- Give the Operators Manual to the customer and explain all operating adjustments and lubrication fully.
- To the best of my knowledge, this machine has been delivered ready for use and the customer has been fully informed as to its proper care and operation.

**Set-Up Date** \_\_\_\_\_ **Signature of Delivery Person** \_\_\_\_\_



## Checklists

**AFTER-SALE CHECKLIST:** It is suggested the following items be checked sometime during the first six months operation of the disk.

- Check the entire disk for loose or missing hardware.
- Check for broken or damaged parts. Make necessary repairs.
- Re-torque the hardware with special attention to the gang axle nuts and locks.
- Safety chain is properly installed and undamaged.
- If possible, run the disk to insure it is functioning properly.
- Check the bearing wear plates are present and not excessively worn.
- Visually check the oil-bath bearing for leaks. If parked unused for a long period in extreme weather conditions, there may be seepage due to expansion and contraction of the metal duo-cone seals. This condition will correct itself when the disk is operated. Lost oil should be replaced before operation.
- Review the entire Operators Manual with the customer and stress the importance of proper and regular lubrication and safety precautions.
- Advise the customer of optional attachments that are available.

**Date Checked** \_\_\_\_\_ **Signature** \_\_\_\_\_

### EACH DAY OF OPERATION CHECKLIST

- Lubricate items required daily and those whose lubrication time is due.
- Look for loose or missing bolts and parts.
- Check hydraulic system for leaks and abraded hoses.
- Check tire pressures and wheel lug nuts.
- Check all pins have retaining hardware in place.
- Check all oil-bath bearing assemblies for leaks. Check bearing wear plates are present.
- Be sure all gang components are tight on the axles and axle nuts are tight and axle locks are present.

### BEFORE EACH SEASON CHECKLIST

- Be sure recommended lubrication is performed.
- Inspect all oil-bath bearing assemblies are tight and dry and if wear plates need replacement.
- Check hydraulic system for proper operation and leakage.
- Check tire pressures and wheel lug nuts. Check for end play in wheel bearings and repack if necessary.
- Be sure proper operating adjustments have been made for your conditions.



## Safety Decal Identification and Placement

REF NO	PART NUMBER	DESCRIPTION	NO REQ'D
1	5KBLG2FT	FRONTIER Decal	2
2	-see parts section	Model Number Decal	2
3	5KBRFLYW	Yellow Reflector Strip	4
4	5KBDWPHF	WARNING - Avoid serious injury from injection of pressurized.....	1
5	5KBDCASI	CAUTION - To Avoid Serious Injury:	1
6	5KBDDDNA	DANGER - To avoid injury or death, do not adjust.....	1
7	5KBDWMTS	WARNING - Do not exceed implements maximum transport speed.....	1
8	5KBDWICL	WARNING - Avoid serious injury from crushing or pinning.....	1

## Safety First Guidelines

When you see this symbol on your machine or in this manual, be alert to the potential for personal injury.



Indicates death or serious injury will result if proper precautions are not taken.



Indicates death, serious injury or property damage can result if proper precautions are not taken.



Indicates some injury or property damage may result if proper precautions are not taken.



Carefully read all safety messages in this manual and on your machine safety signs. Keep safety signs in good condition. Replace missing or damaged safety signs. Be sure new equipment components and repair parts include the current safety signs. Replacement safety signs are available from your John Deere dealer.

Learn how to operate the machine and how to use the controls properly. Do not let anyone operate the machine without instruction. Keep your machine in proper working condition. Unauthorized modifications to the machine may impair the function and/or safety and affect machine life.

If you do not understand any part of this manual and need assistance, contact your John Deere dealer.

**Prepare for Emergencies:** Keep a first aid kit and a fire extinguisher handy. Keep emergency numbers for doctors, ambulance service, hospital and fire department nearby.

**Wear Protective Clothing:** Wear close fitting clothing and safety equipment appropriate to the job. Operating equipment safely requires the full attention of the operator. Do not wear headphones or use a cell phone while operating the machine.

**Protect Against Noise:** Prolonged exposure to loud noise can cause hearing impairment or loss. Wear suitable hearing protection to prevent damage to your hearing.

**Store Equipment Safely:** Securely store equipment by either lowering to ground or chocking wheels to prevent movement. Do not allow children or others to play on or around equipment.

**Dispose of Waste Properly:** Improperly disposing of waste can threaten the environment and the ecology. Potentially harmful waste used in this equipment includes gear oil in the oil-bath bearings and fluid in the hydraulic system. Use leak proof containers when draining fluids. Do not use food or beverage containers that may mislead someone into drinking from them. Do not pour waste onto the ground, down a drain or into any water source. Obtain information about the proper way to recycle or dispose of waste from your local environmental or recycling center, or from your John Deere dealer.

## Attaching the Disk to the Tractor

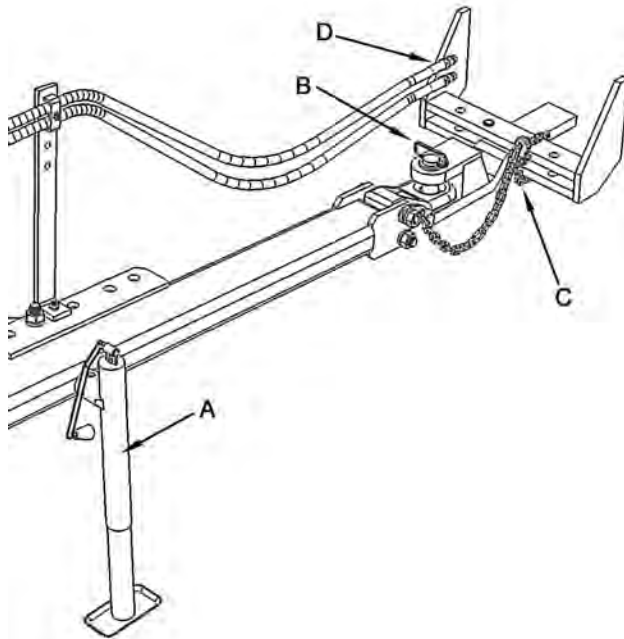

The disk is equipped with a fixed tongue attached to the disk hitch with two 1" grade 8 bolts. The tongue is designed to be attached to a clevis type tractor drawbar.

Though not essential, for best results, the tractor used to pull this unit should be equipped with a swinging drawbar.

The following procedure is recommended to attach the tractor to the disk. This procedure is best carried out with the disk in the raised position and the transport lock installed over the hydraulic cylinder. Use the hitch jack (A) to raise or lower the tongue to the level where it will fit into the tractor drawbar clevis. Back the tractor to the drawbar tongue and install the drawbar pin (B) and its retaining hardware. This procedure may take more than one attempt – *safety takes time*.

Install the safety chain (C).



**CAUTION:**  
Do not allow others to stand between the tractor and disk when moving the tractor.  
Do not allow others to position themselves to install the drawbar pin while operating the tractor.

Prevent serious injury or death to you or others caused by unexpected movement of the machine. Engage the parking brake and/or place transmission in PARK, shut off engine and remove key before working around hitch.

## Transporting the Disk

Clean both quick disconnects (D) and tractor couplers before connecting. Shut off the tractor and move the hydraulic levers back and forth to relieve pressure in open-center hydraulic systems. Connect the hydraulic hoses to the tractor couplers. For ease of use, attach hoses in the corresponding couplers which lower the disk when the hydraulic lever is moved forward and raises it when the lever is moved backwards.



**CAUTION:**  
Escaping fluid under pressure can penetrate skin causing serious injury. Avoid this hazard by relieving pressure before disconnecting hydraulic lines. Tighten all connections before applying pressure. Search for leaks with a piece of cardboard. Protect your hands and body from high pressure fluids.

If an accident occurs, see a doctor immediately. Any fluid injected into the skin must be surgically removed within a few hours or gangrene may result.

Turn the jack handle to take weight off hitch jack. Unpin jack, remove pin, swing jack up into transport (horizontal) position and re-pin.

If the tractor is equipped with a swinging drawbar, make sure the drawbar is locked in the center position.

Connect warning lights to the tractor outlet and test they are operating properly. Make sure the SMV sign is installed and visible from the rear of the disk.

Check tire pressure and wheel bolts – adjust and tighten if necessary.

## Adjusting the Transport Levelling Control Arm

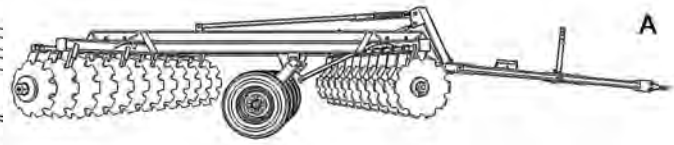
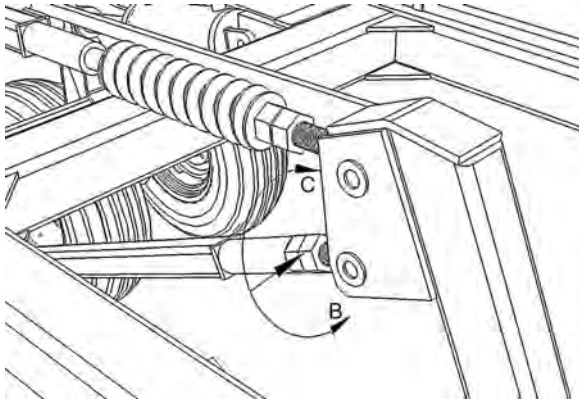

With the disk attached to the tractor, the hydraulics connected and with the transport stay removed from the hydraulic cylinder, the disk can be adjusted to transport level as in illustration A. The adjustment is carried out by turning the nuts indicated in the illustration. When the disk is raised out of the ground in the transport position, there is pressure

against these nuts. Therefore, to make adjustment easier, lower the disk to the ground to take pressure off the nut. The nut can then be turned easily by hand or wrench. To lower the front of the disk as in illustration B, turn the nuts in the direction indicated as B. To raise the front of the disk as in illustration C, turn the nuts in the direction indicated as C. It may be necessary to raise and lower the disk a number of times to attain the desired result. Once the disk is level, lock the nuts together on the eyebolt shaft. This adjustment remains unchanged as long as there is no change in the tractor hitch height.

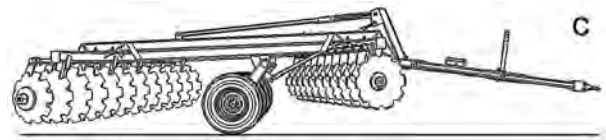
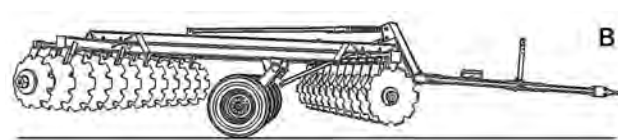

**WARNING:** To avoid serious injury to self or others, do not allow anybody on or near the disk when it is being raised or lowered. In particular, if someone other than the tractor operator is making adjustments to the disk, the tractor should be switched off while adjustments are being made and only restarted when that person is well clear of the disk.

## Transporting the Disk

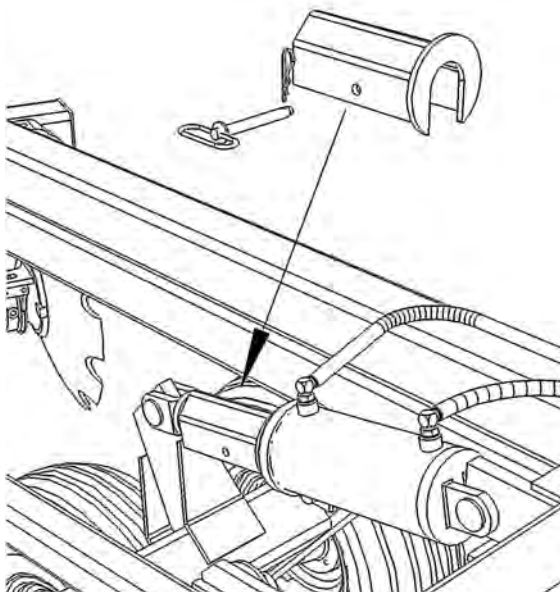

Raise the disk to its maximum height by completely extending the hydraulic cylinder. Install the transport stay over the hydraulic cylinder rod with the plated end against the head gland of the cylinder. Install the retaining pin. On tractors with open centered hydraulics, switch the tractor off and relieve the hydraulic pressure by moving the hydraulic spool lever back and forth. With closed center systems, carefully use the hydraulics to take the pressure off the hydraulics and allow the weight of the disk to be taken up by the transport stay.

## **Transport Safety**

- Never allow riders on the tractor or disk. Serious injury or death can result from falling in the path of the disk while in operation or transport.
- Observe laws and regulations while transporting disk. Never transport disk at speeds greater than 20 mph (32 km/h). Reduce speed and exercise caution on turns, bridges, rough roads, steep grades and other adverse conditions.
- Install all locking devices before transporting disk. Without these devices installed, the disk could fall during transport and cause injury or death to the operator or bystanders and/or damage to the disk, tractor and property.
- Always use safety chains to secure the disk to the tractor during transport. Provide only enough slack in chain to permit turning. A safety chain will help control drawn equipment should it accidentally separate from the drawbar.
- Ensure the load does not exceed the recommended specifications of the tractor. The tractor must be heavy and powerful enough with adequate braking power for the towed load.
- Keep the SMV emblem and side and rear reflectors clean and visible.
- Use headlights, flashing warning lights and turn signals day and night. Follow local regulations for equipment lighting and marking. Keep lighting and marking visible and in good working order. Replace or repair lighting or marking that has been damaged or lost.
- Use the proper size and grade of pin to attach the disk to the tractor.
- If the tractor is equipped with a swinging drawbar, be sure to pin it in the center position before transporting the disk.
- Check wheel lug nuts for tightness and ensure tires are properly inflated and free of damaging cuts and abrasions. The failure of either of these components can cause the disk to swing uncontrollably and make it difficult to control the tractor.
- Remove debris and loose soil from the disk before traveling on public roads. Falling debris and soil can be a hazard to following and approaching traffic.
- Do not tow another implement behind the disk unless proper modifications have been made and it is permitted by local ordinances.

## **Operating Safety**

- Become familiar with the disk and its operation before using the unit. Read this manual carefully and contact your dealer if you have any questions.
- Never allow riders on the tractor or disk. Serious injury or death could result from falling in the path of the disk while in operation or transport.
- Be sure bystanders are clear of the disk before raising or lowering the disk. Accidental movement of the controls or hydraulic failure could cause the disk to suddenly fall.
- Be sure bystanders are clear of the disk before operating the disk. Before entering the tractor, walk around the disk making sure no one is on, under or in front of the disk. Moving the disk while someone is between or in front of the gang assemblies could result in serious injuries or death.
- Never work under a raised disk. Always lower the disk to the ground before inspecting or servicing. Never rely on the hydraulic system to hold up the disk.
- Use extreme caution when working around disk blades. The blades are sharp and could cut hands, legs, etc. Wear gloves to handle disk blades or gang assemblies.
- Do not operate close to ditches, deep bodies of water or on excessively steep slopes.
- Before dismounting from the tractor to service or make adjustments, always
  1. Lower the disk to the ground.
  2. Shut the tractor off.
  3. Engage the tractor's parking brake or place transmission in park.
  4. Relieve the hydraulics by moving the control back and forth.
  5. Remove the key.
- Unanticipated movement of the disk while working around the disk gangs could result in serious personal injury or death.

# Operating the Disk

## General Operating Guidelines

- Use the recommended size tractor. Weight is as important as horsepower. Too light a tractor will be overpowered by the plowing action of the disk and its front end will be swung to the left, requiring constant steering corrections.
- Always raise the disk out of the ground before turning. If pulling a harrow, roller or other toolbar behind the disk, raise the disk just clear of the ground before turning.
- In the field do not back-up with the disk in the fully raised position. Raise the disk just clear of the ground to prevent the disk from overbalancing to the rear which may damage the control arms.
- Speed, depth and soil type and condition all determine how level the ground left behind the disk. To minimize ridging or gouging, limit the disking speed to 4-6 mph.
- On tractors equipped with a swinging drawbar, allow the drawbar some movement when working in level or gently rolling fields. In severely rocky conditions, heavy clay or tree stumps allow more swing in the drawbar. In all other conditions, lock the drawbar in the center position.
- Pulling a drag or heavy harrow behind the disk can reduce side draft and aid in levelling the soil.

## Disk Adjustments

All single offset disks have a single characteristic in common. Because the front gang of disk blades are set at an angle to their direction of movement and because these blades are working in “new” ground compared to the rear disks which are working in ground already partially tilled by the front blades, a single offset disk tries to rotate clockwise as it is pulled forward through the field. To perform optimally and to reduce stress and premature wear on components, it is desirable that the machine draft in a straight line behind the tractor. As well, the concavity of the disk blades is such that in the center angle setting the blades will accomplish the most tillage with the least horsepower and minimum wear to the blades. When the disk drafts to one side (i.e. “dog tracking” or “crabbing”) the gang angles are changed and the quality of the tillage suffers.

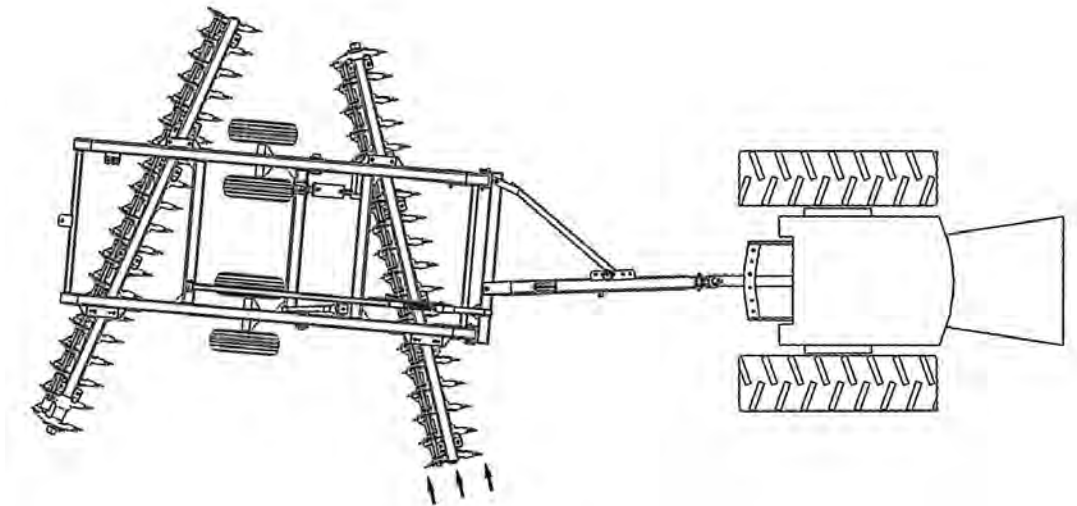

There are three types of adjustments that affect the draft of the disk.

### REPOSITION THE HITCH.

This adjustment is best accomplished when the disk is not attached to the tractor. **SUPPORT** the bridle crossbar to which the hitch and side arm are attached with a jack and stand. Alternatively the head of the bridle mast can be **CHAINED** back to the first member of the main frame. Next **LOOSEN** the bolts attaching the hitch and side arm to the bridle. **REMOVE** the pin attaching the side arm to the plates on the side of the hitch.

The hitch bar can be placed in five fixed positions. Moving the hitch towards “L” as illustrated will cause the rear of the disk to move to the left when viewed from behind. Moving towards “R” will cause the rear of the disk to move to the right when viewed from behind.

Swing the hitch to the desired position and reattach the side arm through the appropriate bolt holes in the plates on the side of the hitch. Tighten the 1" bolts to approximately 700 ft/lbs ft/lbs and recheck after the next 10 hrs of use.

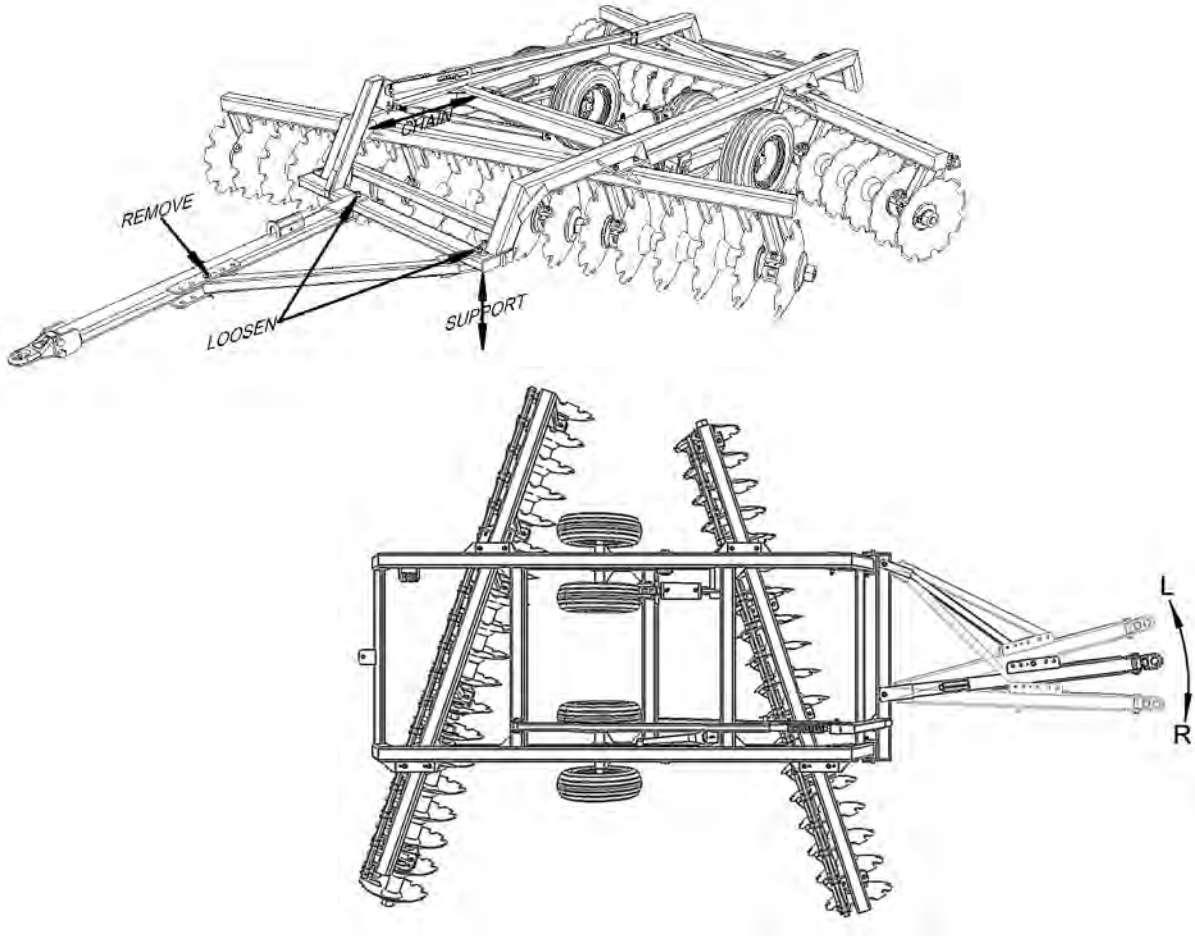

**CHANGE THE GANG ANGLES**

The position indicated as the optimal gang angle is the setting which yields the best performance while minimizing blade wear. The second setting is intended to extend the useful life of the disc blades. Blade wear is essentially the same as decreasing the gang angle. To maintain performance of worn disk blades, the gang can be moved to this position to maximize blade usage.

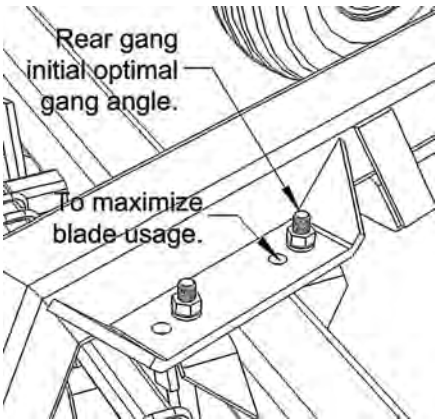
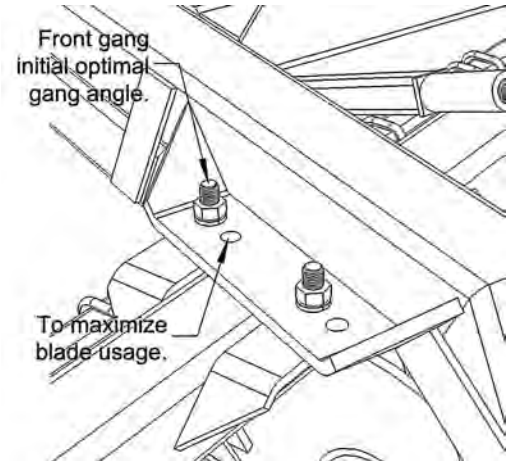



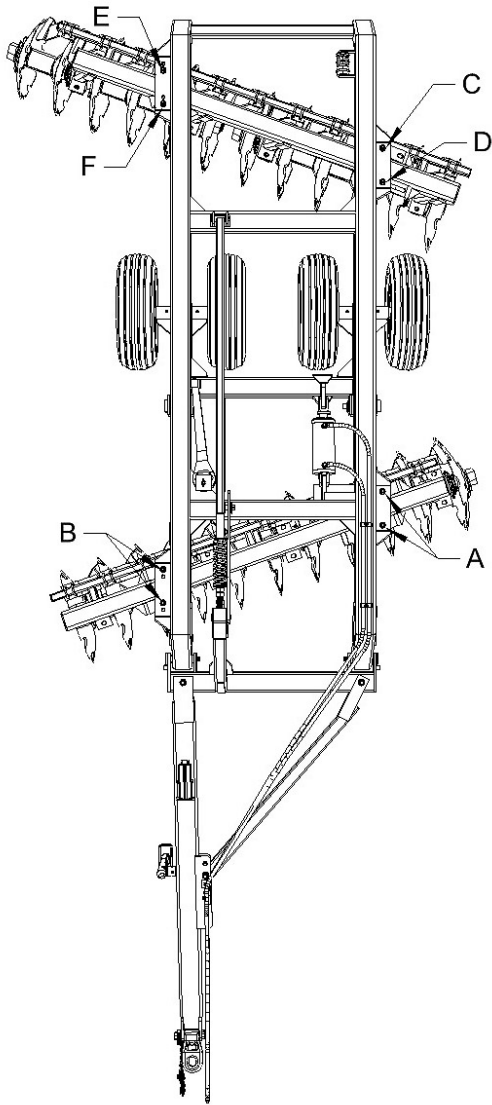

To change the angle of the front gang, loosen the bolts at positions A and remove the bolts at positions B. With the disks slightly lowered into the ground, use the tractor to carefully move the disk either forward or backwards to the desired position. Reinstall bolts B and tighten all four bolts to 400 ft/lbs.

To change the angle of the rear gang, loosen the bolts at positions C and D, and remove E and F.

The rear gang of the disk can also be adjusted from side to side. If the rear gang is moved to the left, it increases the amount of soil being thrown into the furrow. If the rear gang is moved to the right, it will decrease the amount of soil being thrown into the furrow. To shift the rear gang, loosen the bolts at positions D and E and remove the bolts at C and F. With the disk blades resting on the ground, moving the disk either forward or backward will cause the gang carrier to shift to the right or left as desired. Align the bolt holes, reinstall the bolts and tighten all four bolts to 400 ft/lbs.

#### ADJUST THE LEVELING CONTROL ARM

The leveling control arm is used to transfer pressure to the rear of the disk in order to increase penetration of the rear disk blades. Pressure is increased by tightening the adjustment nut against the spring. This adjustment is easiest to make when the disk is in the raised transport position and there is no pressure on the nut. Once the desired setting is made, lock the first nut with the second nut on the eyebolt. When the disk is lowered to the operating position, take care the spring is never fully compressed. Increasing pressure against the spring will put more down pressure on the rear blades. Carrying the disk slightly with the wheels while operating will allow the disk to pivot on the wheels and result in more even blade penetration front to rear. If the disk is operated with the wheels fully raised, little or no pressure should be placed on the spring. If disking through a sharp depression or ditch, raise the disk slightly to prevent excessive pressure on the spring and levelling arm.

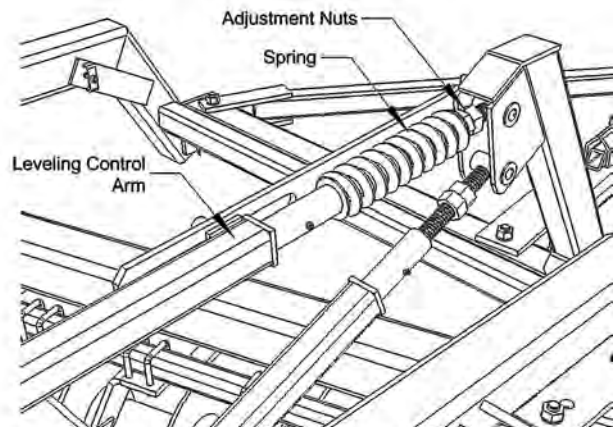

Increasing pressure on the rear gang can reduce dog tracking by creating a side thrust opposite to the thrust of the front gang.



## Service and Maintenance Safety



- Before servicing the disk, always:
  1. Lower the disk to the ground.
  2. Shut the tractor engine off.
  3. Engage the tractors parking brake and/or place transmission in park.
  4. Relieve the hydraulics by moving the control lever back and forth.
  5. Remove the ignition key.
- Never work under a raised disk. The disk could fall suddenly causing serious personal injury. Never rely on the hydraulic system to hold the disk up.
- Periodically visually inspect the entire disk. Hydraulic fluid leaks and broken, missing or faulty parts can create a hazard. Make necessary repairs.
- Use caution when inflating tires. Use a clip-on air chuck, extension hose with gauge, and stand to one side away from the tire when inflating to avoid the possibility of personal injury due to blow-offs, etc. Maintain proper air pressure in the tires. Never exceed the manufacturer's maximum pressure displayed on the sidewall of the tire.
- Before disconnecting any hydraulic line relieve the pressure. Escaping hydraulic oil under pressure can have sufficient force to penetrate the skin causing serious personal injury. If injured by escaping hydraulic fluid, obtain medical treatment immediately.
- Handle the gang assemblies with care. The disk blades are sharp and can cut or slice skin. Use chock blocks to prevent the gang assemblies from rolling during servicing. Wear gloves when handling the disk blades or gang assemblies.
- After working on the hydraulic cylinder or any other components of the hydraulic system, carefully cycle the hydraulic cylinder several times to purge air from the system and check all components for leaks. Always be sure the hydraulic lines are free of air and do not leak. ORB fittings may not leak even though they are only finger tight – tighten with a wrench. Check hydraulic hoses for cuts or abrasions and replace if necessary.
- Securely support any machine elements that must be raised for service work. Use suitable lifting devices and support stands where required. If using chains or straps make sure they are of sufficient strength for the load and are in good repair.
- To avoid injury wear gloves, steel-toe boots, safety glasses, hearing protection, safety helmet and other safety equipment where warranted.
- Understand the service procedure before doing the required work. Keep the work area clean and dry.

## Lubricate the Disk

- The following illustrations highlight those areas of the disk subject to stress and wear. Unless indicated otherwise, these fittings should be greased daily or after every 10 hours of operation.
- Use a pressure lubrication gun and apply a sufficient amount of No. 2 multi-purpose lithium grease or equivalent to flush out the old grease. Wipe the grease fitting clean before greasing.
- Grease all fittings before first use of the season and before storage at the end of the season.

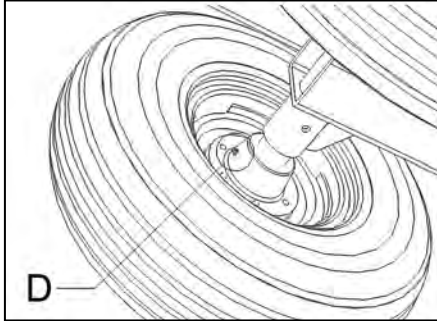

Grease wheel bearings (D) sparingly – six “shots” every 150 hrs.

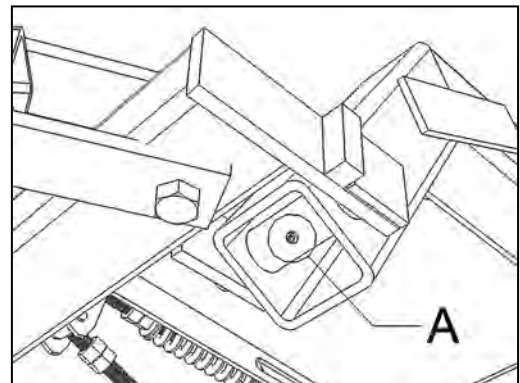
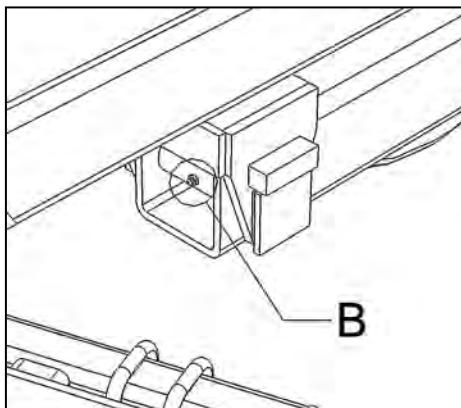
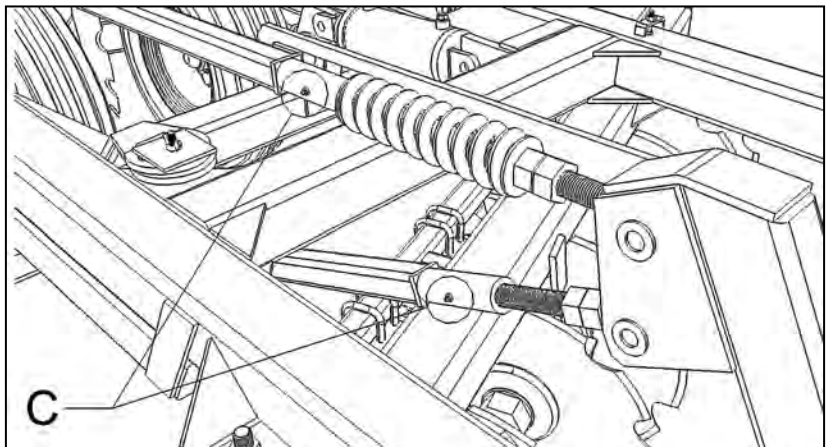
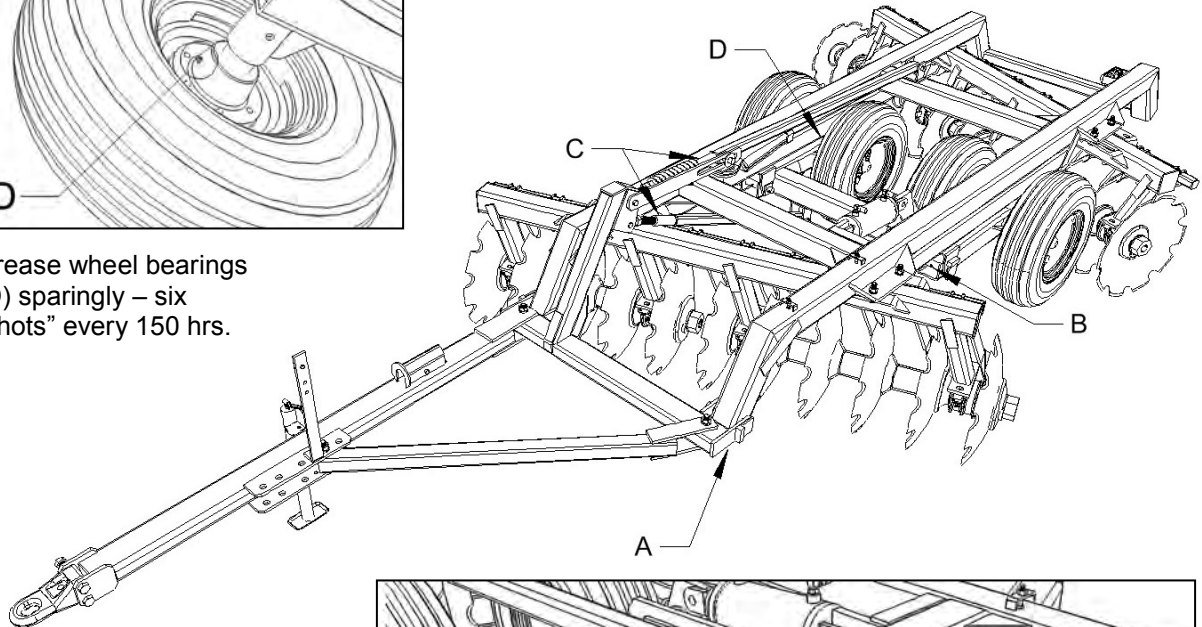

## Check the Oil-Bath Bearings

Visually check the oil-bath bearings daily. Oil-bath bearing assemblies can leak oil from three locations and attention should be paid to these areas. **A** - Oil can seep from between the bearing housing and the end cap or from around the bolts that hold the end cap to the housing. This condition is caused by loose bolts or damaged gaskets. Gaskets are placed between the end cap and the housing to preload the taper bearings in the housing. The solution is to tighten the bolts (30 ft/lbs) or replace the gaskets. **B** - Oil can seep past the check plugs. Plugs may use a pipe thread. Remove, clean the threads, apply "pipe dope" or Teflon tape and reinstall. **C** - Oil may seep by the metallic duo-cone seals. This may be caused by worn seals, loose gang axles or extreme temperature fluctuations. Worn seals should be replaced immediately to prevent catastrophic bearing failure. Such a failure will ruin all the other components of the bearing. Loose gang axles can allow the bearing flanges to move outwards and thereby allow the seals to separate. Be sure to keep gang axles tight. Because the seals are made of metal, they can expand and contract with extreme temperature fluctuations. When they contract the sealing surfaces separate and small amounts of oil can escape. This will normally occur when the disk is in storage. Putting the disk to use will normally allow the seals to re-seat themselves. Check the oil and add 90W gear oil if necessary.

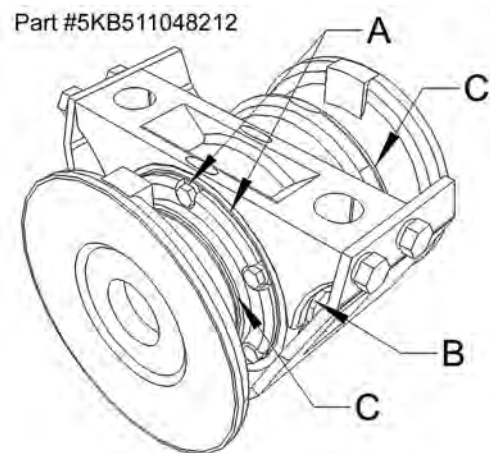
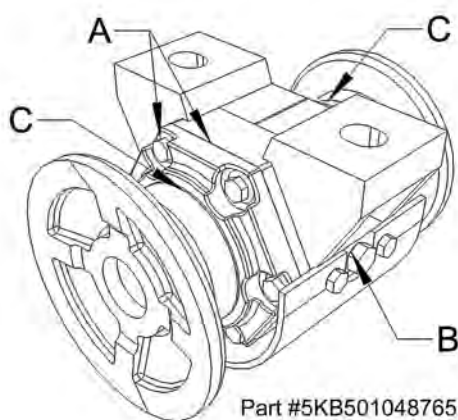

## Adjusting the Scrapers

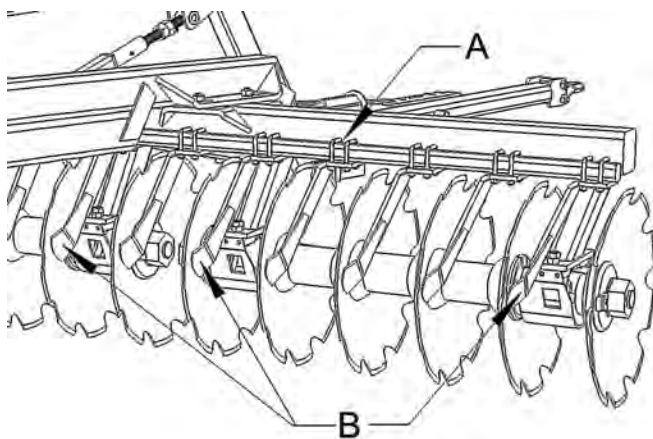

Adjust the scrapers as close to the disk blades as possible without touching the blades. To move a scraper, first loosen the u-bolts (A) holding it to the scraper bar. Use a hammer to alternatively tap the top side of the u-bolts and the scraper itself in the required direction. Once in position tighten the u-bolts equally. Turn the blades occasionally while tightening the u-bolts to ensure the scraper is not contacting the disk blade.

In some conditions (e.g. heavy trash or virgin ground) plugging can occur at the bearings. Removing the scrapers (B) at these locations can alleviate the problem.

## Repack and Pre-Load Wheel Hub Bearings

The wheel bearing pre-load should be set periodically or more often if transported frequently. Raise the tire so it can rotate and:

1. Remove the dust cap from hub.
2. Remove cotter pin from nut and spindle.
3. While turning the tire, tighten the castellated nut until there is a slight but noticeable drag on the bearing. Do not back the nut off. Place the cotter pin in the nearest hole to secure the nut. Replace the dust cap and gasket.

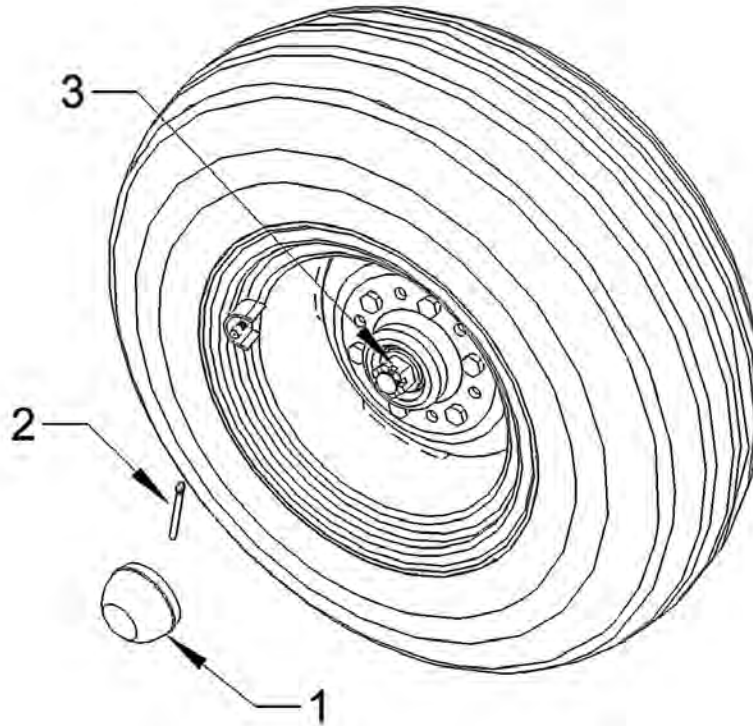

Repack the wheel hub bearings yearly by:

1. Remove the tire from the hub.
2. Remove the dust cap and gasket.
3. Remove the cotter pin and remove the castellated nut from the end of the spindle.
4. Slide the hub off the spindle taking care not to damage the seal..
5. Clean bearing cones, dust cap and nut with kerosene or other appropriate solvent.
6. Clean the inside of the hub and inspect the bearing cups and the seal. If they show excessive wear or are damaged, replace both the cups and cones and seal. Though it is not always necessary, it is advisable to replace the seal whenever repacking the hubs.
7. Pack the bearing cones and inside cavity of the hub with No. 2 multi-purpose lithium grease or equivalent. Make sure no foreign material contaminates the lubricant.
8. Place the rear bearing cone into the back of the hub and press the seal into the hub. Place a light film of grease on the seal surface and carefully slide the hub onto the spindle taking care not to damage the seal.
9. Place the outside bearing cone over the spindle and into the hub.
10. Install the castellated nut and follow the procedure for setting the pre-load.
11. Reinstall the dust cap and tire.

Check the wheel lug nuts and wheel bearing pre-load after the next week of operation.

## Fluid and Fastener Specifications

- DISK GANG ASSEMBLY AXLES: The disk gang assembly axles are 1-5/8" in diameter (optional 2 -1/8") and are threaded at either end. A heavy cast nut is installed at either end and tightened to complete the rigid gang assembly. To insure proper functioning and maximum durability, the axle nuts should be checked and tightened daily during the first (7) seven days of operation when the disk is new or after replacing any of the gang assembly components. When installing the nut, apply an anti-seize compound to the threads. Over tightening the gang axles can damage components of the gang assembly.

**Recommended Torque (Ø1-5/8") – 800-1000 ft/lbs**  
**Recommended Torque (Ø2-1/8") – 1000-1200 ft/lbs**

- FASTENERS: Tighten all fasteners after the first day of operation and seasonally thereafter to the following settings.

Bolt Diameter	Torque (ft/lbs)	
	Grade 5	Grade 8
3/8"	23	33
1/2"	57	80
5/8"	112	159
3/4"	200	282
7/8"	322	454
1"	483	682
1-1/4"	840	1363
1-1/2"	1462	2371

The torque values in table are for plated unlubricated bolts and nuts.



- OIL-BATH BEARING OIL: The oil-bath bearing contains back-to-back tapered roller bearings operating in gear oil. The bearing has a check plug on the side of the housing. Oil is filled to the bottom of the check plug hole. Fill oil until it begins to run out the hole.

**Recommended Gear Oil – SAE 90W (API GL-4)**

A heavier weight of gear oil may be used in hot climates where there may be constant temperatures in excess of 90°F.

- TIRE AND WHEEL SERVICE

When checking wheel nut for tightness or remounting the wheel, tighten the wheel bolts in the sequence illustrated.

**Torque wheel nuts to 165-175 ft/lbs.**

Check the tires regularly for cuts or other damage.

Check and adjust tire pressure when tire is cold.

**Maintain tire pressure at 60 psi.**

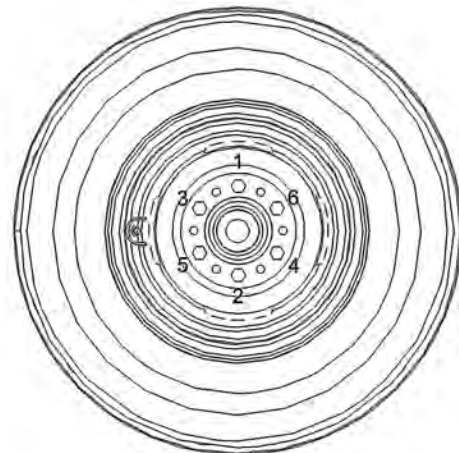

## Keep Gang Assemblies Tight

- To ensure proper function and maximum durability, the axle nuts should be checked and tightened daily during the first (7) days of operation when the disk is new or after replacing any of the gang components.
- Loose axles may bend or break or cause damage to other components of the gang assembly. Maintaining tight gangs is necessary to ensure maximum bearing life.
- A loose gang assembly is evident when some disk blades stop turning when diking or turn at a different speed than other disks on the same assembly.
- To tighten the axle without removing the gang assembly from the disk:

To minimize the possibility of thread damage, clean out the cavity between the inside of the nut and the flat milled surface at the end of the axle. After using compressed air or a pressure washer to remove as much material as possible, pour or spray a light oil or penetrating fluid into the cavity.

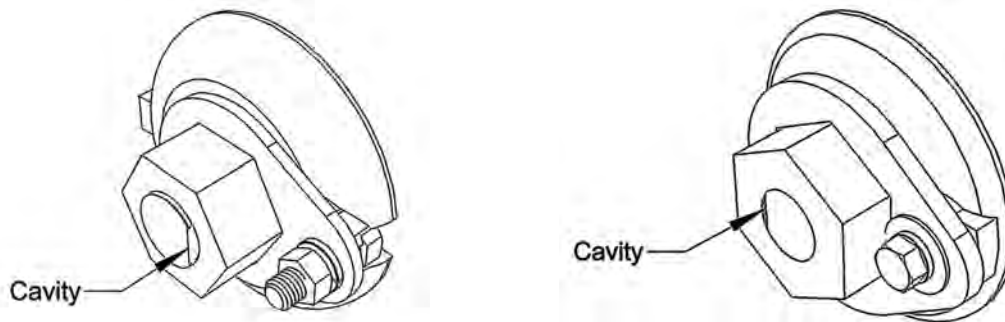

Unbolt and remove the nut locks from the end washers on both ends of the axle. Loosen but do not remove the bolts holding the bearings to the bearing standards. Place one wrench on an axle nut to prevent the axle from turning. Use the other wrench and an extension or a sledge hammer to tighten the axle nut on the opposite end of the axle. Tighten the nut on 1-5/8" axle to 800-1000 ft/lbs and on a 2-1/8" axle to 1000-2000 ft/lbs. Retighten the bearing bolts.

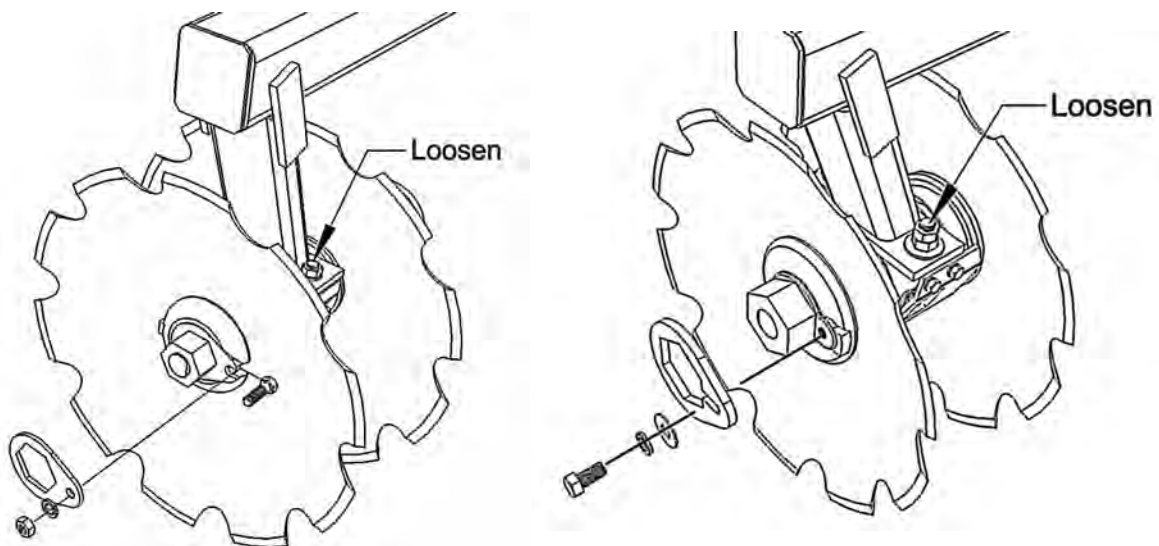

If the gang is excessively loose it may be necessary to completely disassemble the entire assembly and clean the mating surfaces between the spools, bearings, end washers and disk blades.

- If it is necessary to remove and disassemble the gang assembly, use suitable lifting devices and supports to prevent injury.

With the disk lowered to the ground, first remove the scrapers and then unbolt the bearings from the bearing standards. There are four bolts holding each gang assembly to the gang bar. Once the bolts are removed, raise the disk high enough to either roll or pull the assembly from under the disk. Block the gang to prevent it from rolling. Remove the nut locks from both ends of the assembly. Use one wrench to keep the gang from turning while using the other wrench to tighten the nut at the opposite end of the assembly.

It may not be possible to properly tighten the gang if dirt, grit or debris has built-up between the components. In this case remove a nut from one end of the axle, slide off the end washers, bearings, spools and disk blades. Thoroughly clean the mating surfaces between the components and reassemble on the disk gang (see assembly section). Clean the threads on the axle and in the axle nut. Apply an anti-seize compound to the axle threads and reinstall the nut. Tighten the nut and reinstall the nut locks. Place the assembly under the disk and bolt to the gang bar bearing standards. Occasionally turn the gang while tightening the bolts to check the gang turns freely. Retighten the bearing bolts after the first 10-12 hours of operation.

## **Assembly Safety**

- Wear proper attire when assembling disk. Always wear relatively tight and belted clothing to avoid entanglement in equipment. Wear sturdy, grip work shoes and protective equipment for eyes, hands, hearing and head.
- Handle the disk gang components with care during assembly. The disk blades are sharp and can cut hands, feet, etc.
- Disk blade assemblies and disk weldments and components are heavy and awkward. Two-person assembly is recommended. When working with others, try to maintain visual contact and communicate actions and procedures which may present a danger to them.
- Read assembly instructions thoroughly before beginning.
- Use the proper tools and equipment for assembly. Make sure you understand the safe procedures for the motorized equipment and lifting devices you will be using. Make sure tools and equipment are in good repair.
- Use proper supports for the job and chock tires or any other components that could roll inadvertently.
- Purge air from hydraulic systems before operation. After connecting the hydraulic lines, carefully cycle the hydraulic cylinder several times to purge air from the system. Visually check all connections for leaks.
- Never use your hands to check for hydraulic leaks.



## Assemble the Disk

- The disk is normally shipped with the bridle and transport assemblies attached to the frame. The gang assemblies are bolted to the gang bars and the scrapers are bolted to the scraper bars. The hitch, side arm, levelling control assemblies, transports control assemblies, jack and hose holder are bundled together. Tires are shipped loose and the remaining components (hydraulics, lighting, hubs, etc) are crated.
- The parts diagrams in this manual may facilitate assembly of the disk.
- These instructions require a forklift, boomlift or similar type of equipment which is capable of lifting the disk weldments. A minimum 8000 lb outdoor application forklift with fork extensions is a good choice. A tractor to move the disk and charge and operate the hydraulic cylinder will also be required.
- The following tools will also be required:
  1. A selection of chains and straps.
  2. Box end wrench set to 1-1/4" plus 1-5/16" and 1-1/2".
  3. Socket and ratchet sets to 1-1/4" plus 1-5/16" and 1-1/2".
  4. Hammers and sledge hammer.
  5. Pinch bar.
  6. 12" adjustable wrench.
  7. Pliers and vise grips.
  8. 1/2" and 3/4" drive air wrench and sockets.

1. Stand the hubs on end (remove from transport assembly if installed for shipment) and place wheels on top and install and tighten wheel bolts.

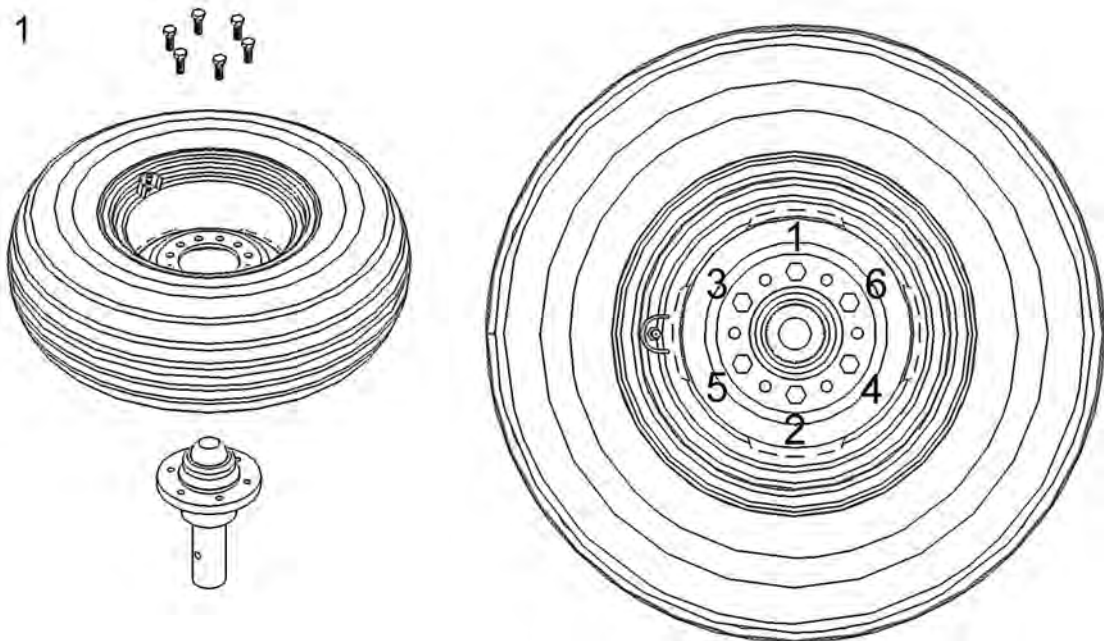

2. Use a chain or strap around the frame and the leg of the transport to keep the transport from dropping when the frame is lifted (see 4). If using a chain, place rubber or matting under the chain to prevent damage to the paint.

3. Run a chain or strap from the top of the bridle mast to the first frame cross member to keep the bridle from falling forward while working on the disk.

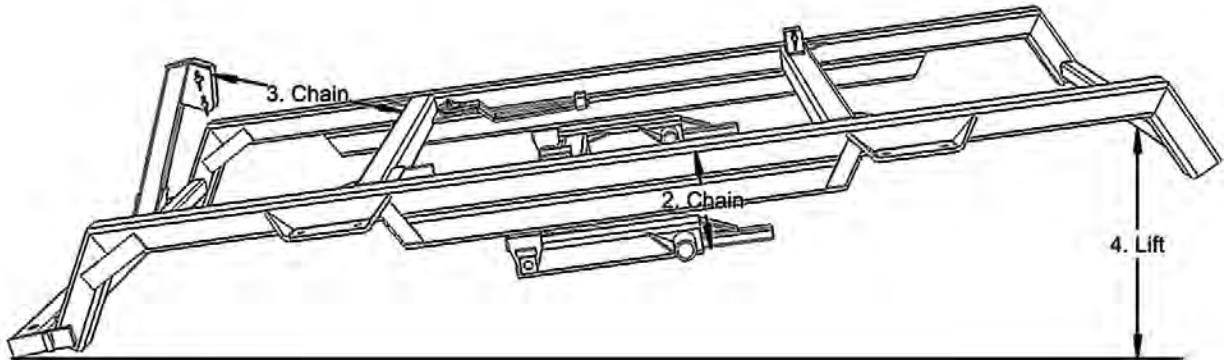

4. Use a forklift or other lifting device to lift the back of the disk frame high enough to slip the spindles into the axle pipes.

5. Slide the hub spindles into the axle pipes and install retainer bolts.

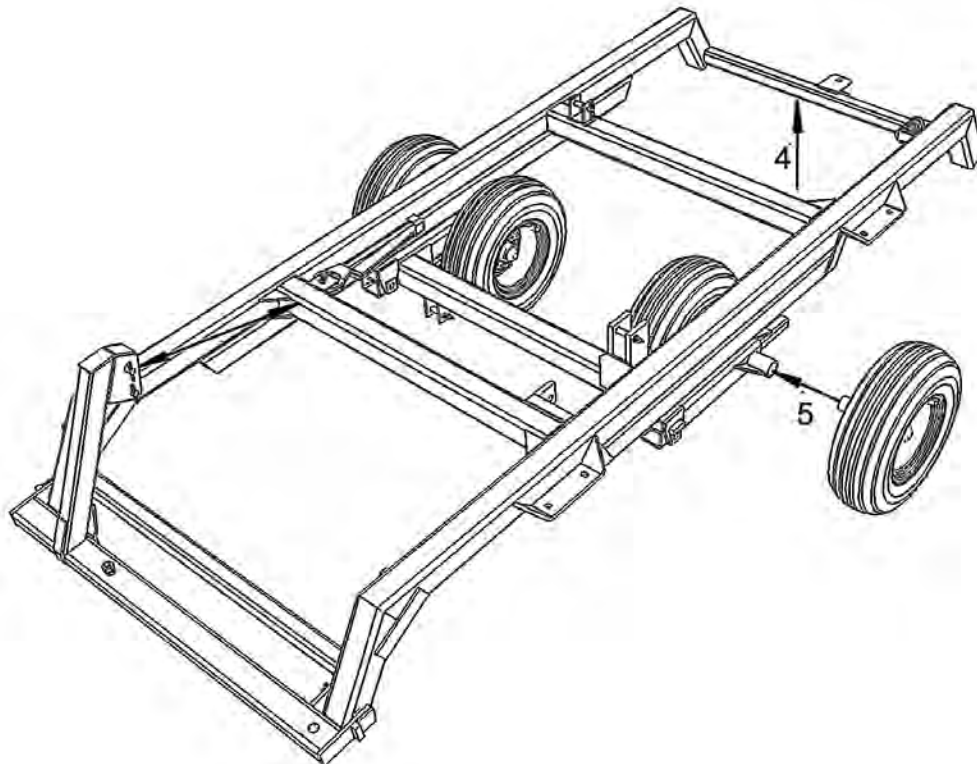

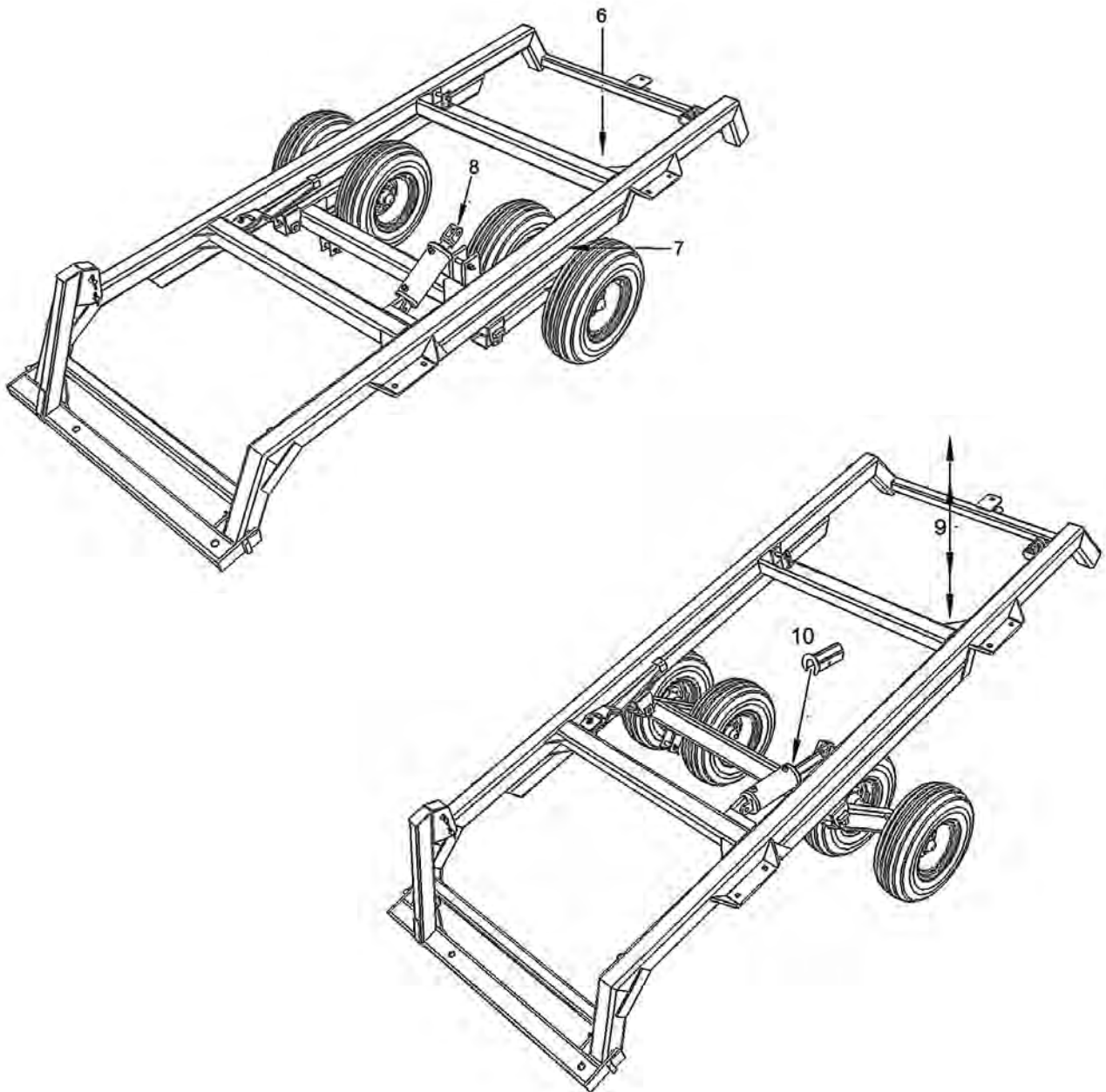

**6.** Lower the frame to the ground.

**7.** Remove the chain or strap placed around the frame and transport in Step 2.

**8.** Attach the hydraulic cylinder to the frame at the clevis on the cross member. Remove the plugs from the cylinder ports to prevent an airlock when the rod/piston moves in the cylinder barrel.

**9.** By raising and lowering the back of the frame, the rod end of the cylinder can be pinned to the transport. Once the cylinder is connected, raise the rear of the disc until the wheels clear the ground. At that point the cylinder should be fully extended.

**10.** Place the transport stay over the cylinder and lower the disk to the ground.

**11.** Chock the tires and place a support under the front right corner of the disk frame.

**12.** If necessary, adjust the chain or strap between the bridle mast and frame cross member to keep the bridle cross member as level as possible. This will simplify the installation of the hitch.

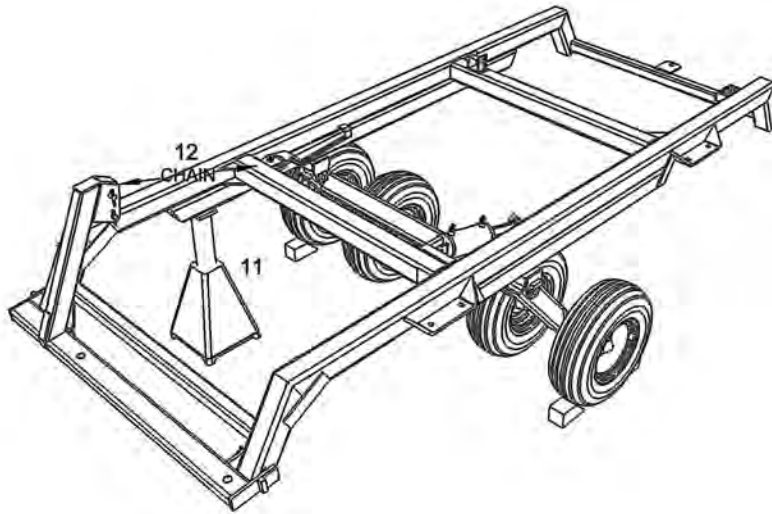

**13.** Using a forklift or other suitable lifting device, attach the hitch to the bridle with a 1" X 6" bolt inserted up from the bottom. Do not tighten the bolt at this time. The hitch should hang from the bridle unsupported.

**14.** Again using a forklift or other suitable lifting device, attach the sidearm to the bridle with a 1" X 6" bolt inserted up from the bottom. Do not tighten at this time. Swing the sidearm and hitch towards each other and attach the sidearm to the hitch at the fourth hole from the front of the side plates, with the pin provided. Tighten the bolts.

**15.** Lift the hitch slightly and remove the chain or strap from between the bridle mast and frame cross member.

**16.** Attach the jack to the hitch and adjust it to support the tongue at approximately 22" (tractor drawbar height) from the ground. Attach the hose holder to the hitch.

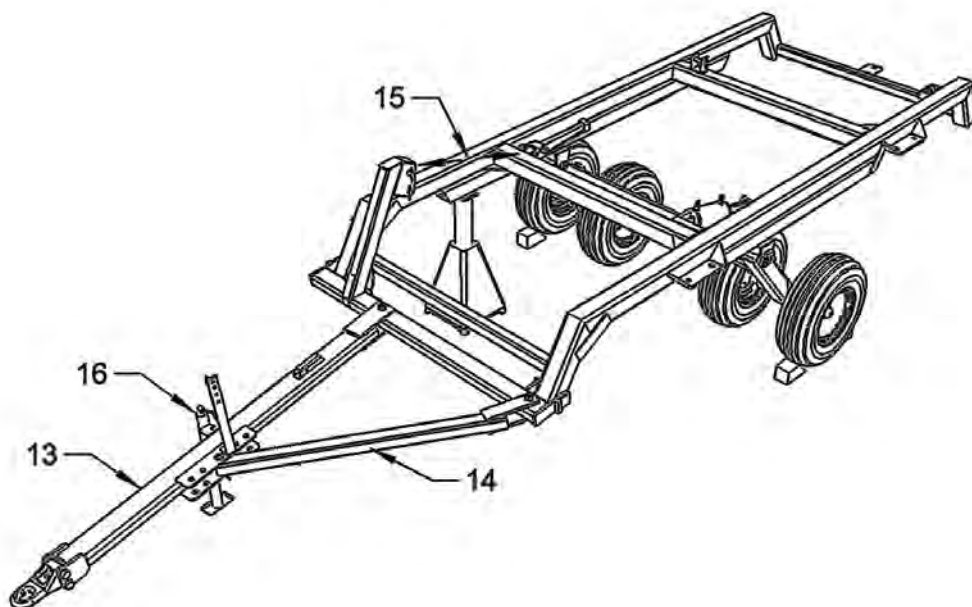

**17.** Install transport control assembly. The transport control assembly consists of one threaded eyebolt on which two nuts are already installed and a length of square tube into which the eyebolt slides. The eyebolt is attached to the bottom set of holes in the mast head. The tube is then slid over the eyebolt and attached to the clevis on the underside of the transport. Once installed, tighten the nuts against the tube.

**18.** Install the levelling assembly between the mast and the frame. There should be no pressure against the spring.

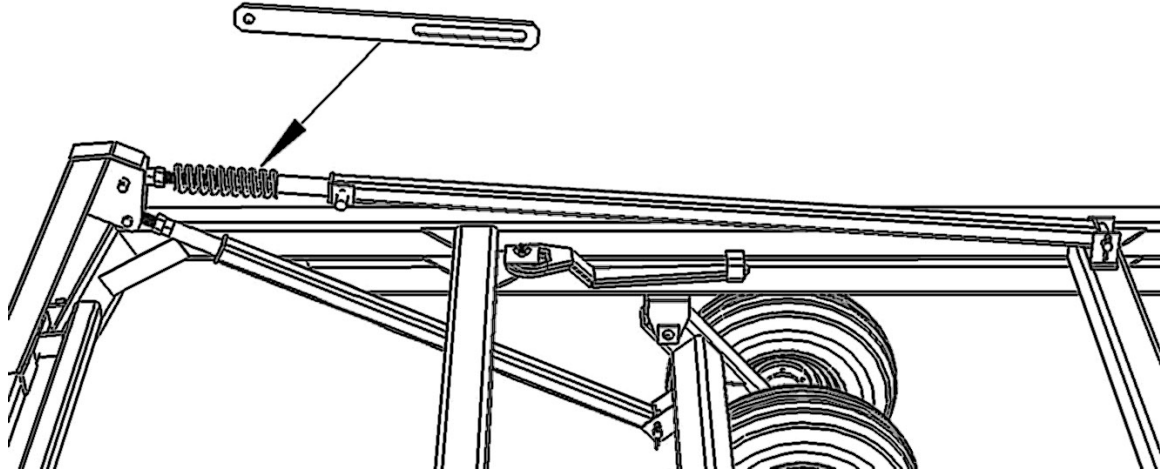

**19.** It is now possible to lift the hitch of the disk and remove the support from under the frame. Leave the tire chocks in place. At this point the hydraulic hoses can be connected to the cylinder but do not charge the system.

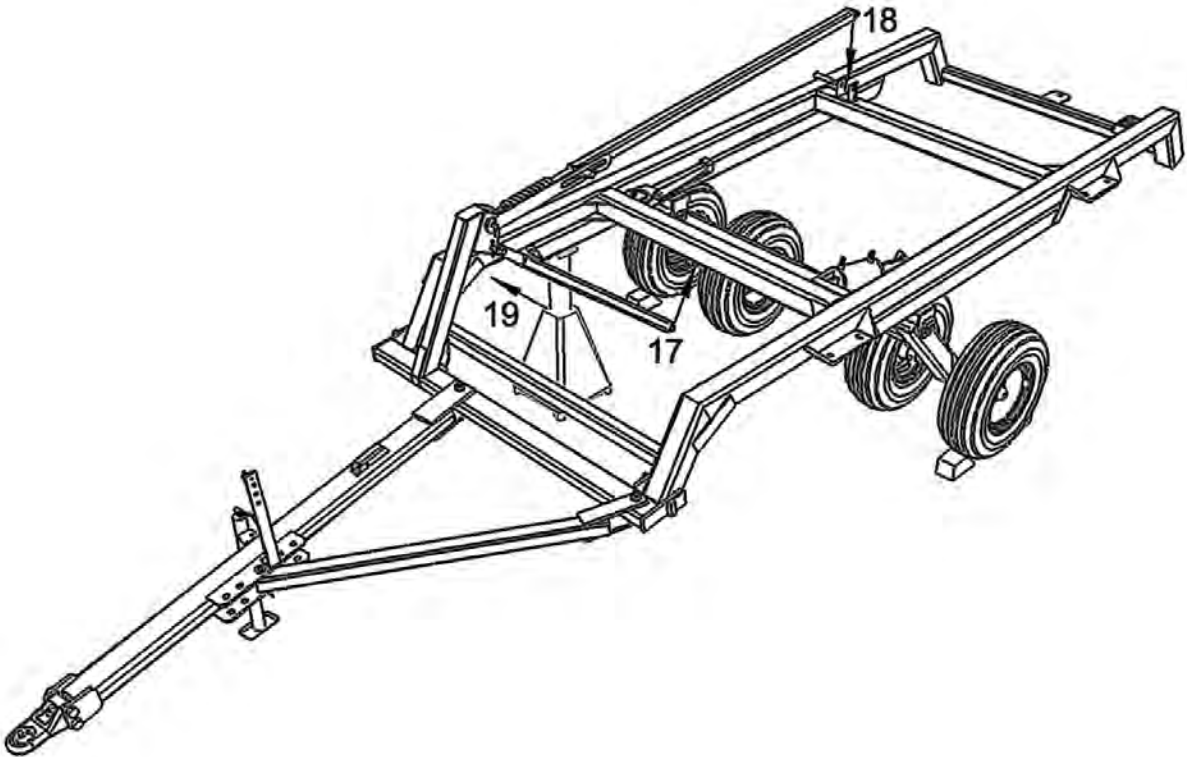

**20.** Place the front gang bar assembly ahead of the hitch at an approximate 20 degree angle and with the disk blades facing the direction illustrated. When the gang bar assembly is attached to the frame the blade scrapers must be to the rear.

**21.** Using a forklift or similar equipment, chain to the end of the hitch. Lift the hitch; unpin the jack, swivel it up and re-pin; and pulling the disk forward, lift it up and over the gang bar assembly. Drop the jack and un-chain from the hitch.

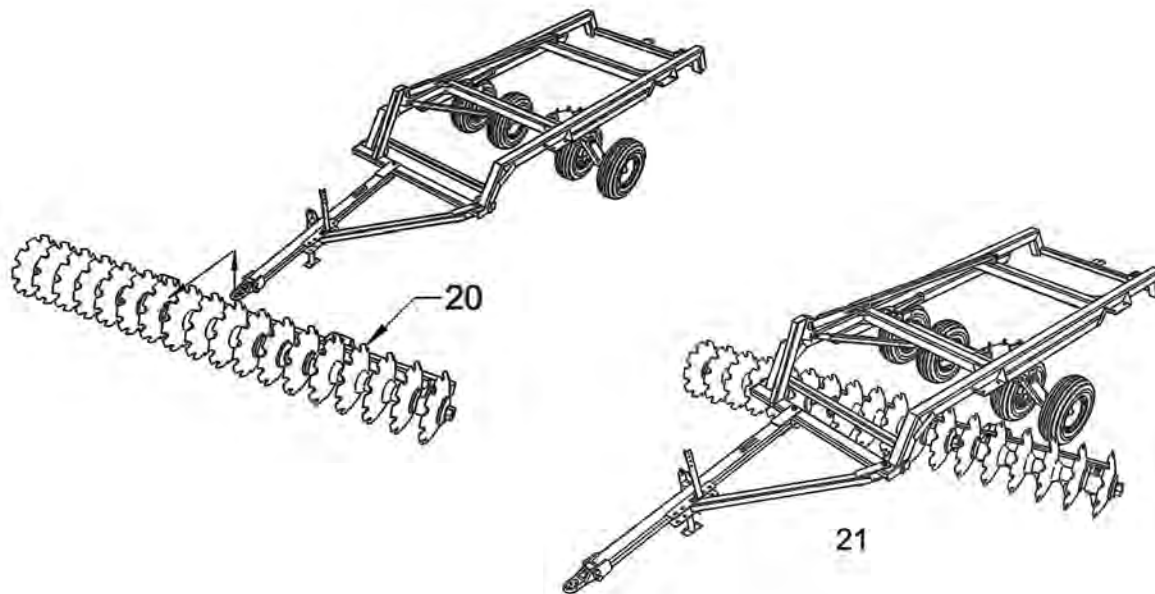

**22.** Using a single strap or chain of sufficient strength wrapped around the center balance point of the gang bar, lift straight up through the frame. This may require fork extensions or a boomlift. Once a single bolt and nut is installed (do not tighten), the gang bar assembly may be lowered and the chain repositioned to ease installation of the remaining bolts. A pinch bar will make this task easier. Install the bolts as per illustrations 23 and 24 on page 30.

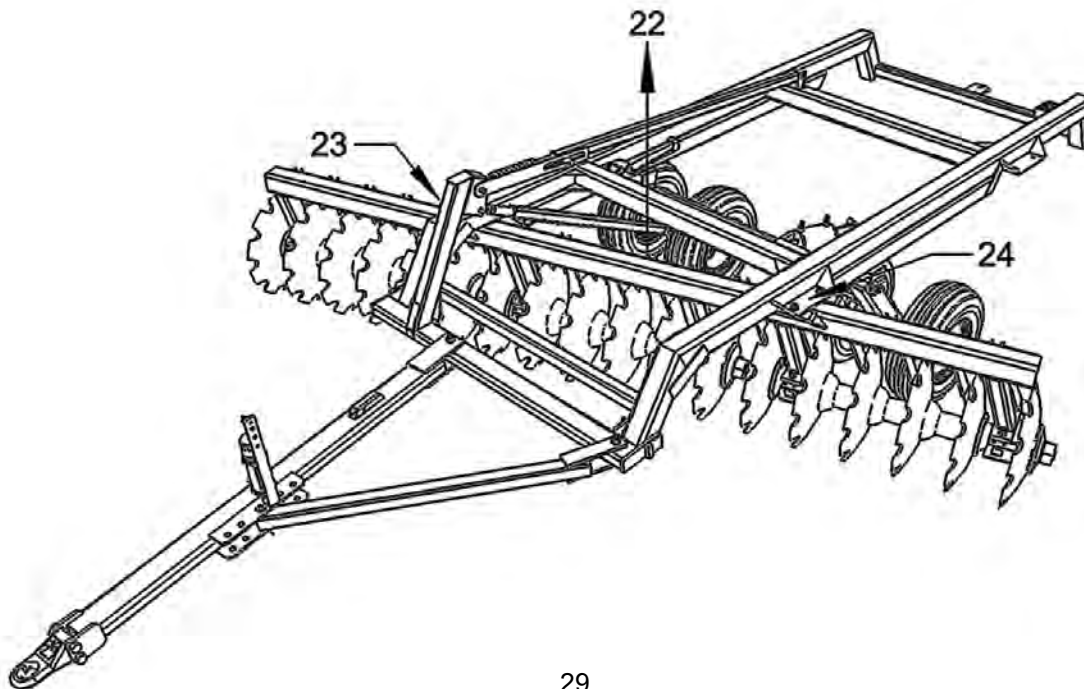

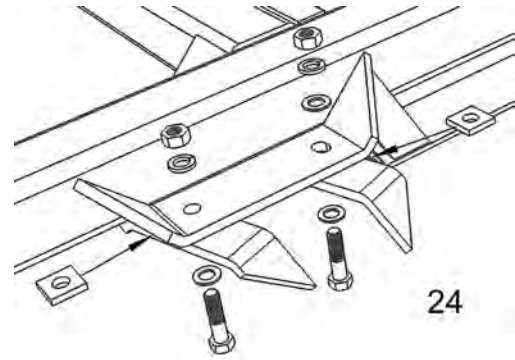
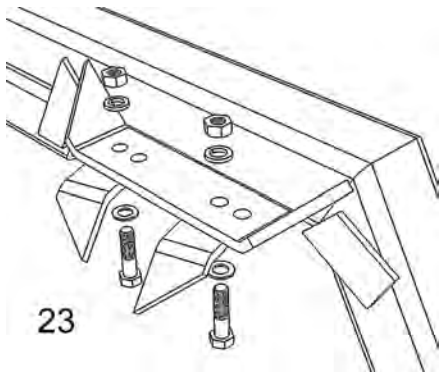

**23 & 24.** Note: Gang bars deleted for clarity.

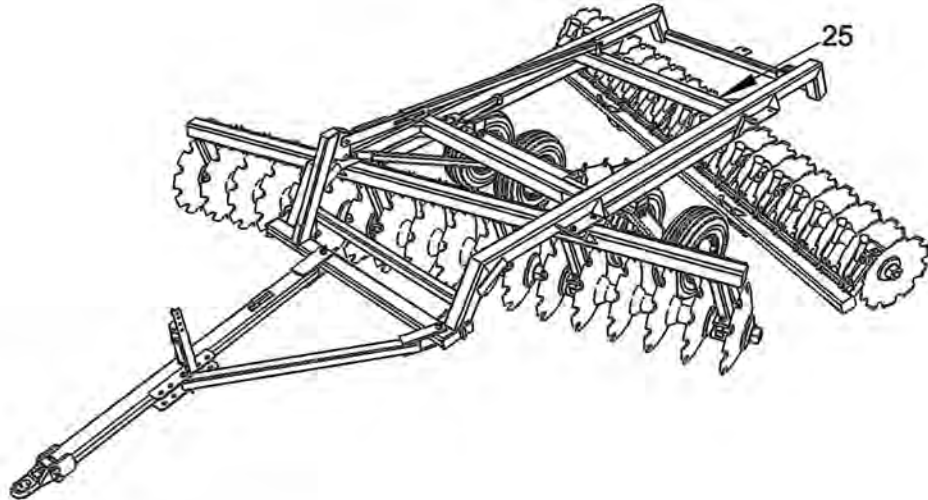

**25.** Place the rear gang bar assembly under the rear of disk with blades facing in the direction illustrated.

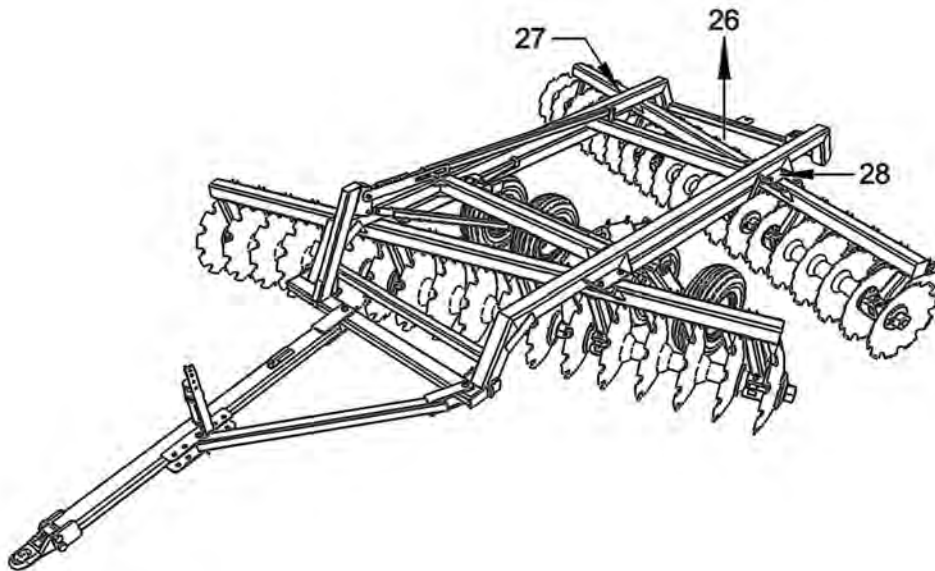

**26.** Use a single strap or chain of sufficient strength wrapped around the gang bar at its center point of balance to lift the bar up to the frame. This may require fork extensions or a boomlift. Once a single bolt and nut is installed (do not tighten), the gang bar assembly may be lowered and the chain repositioned to ease installation of the remaining bolts. A pinch bar will make this task easier. Install the bolts as per illustrations 27 and 28 on page 31.

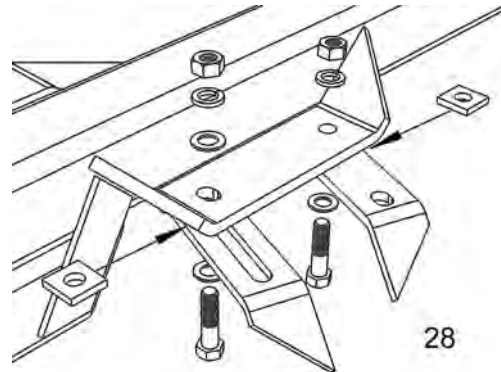
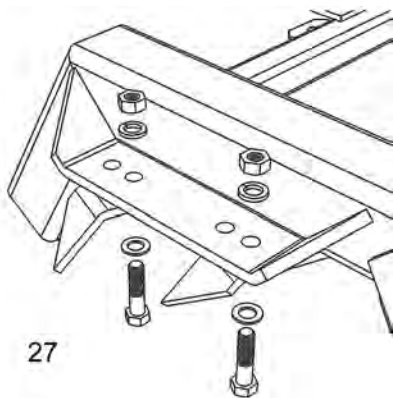

**27 & 28.** Note: Gang bars deleted for clarity.

**29.** Install lights on the rear gang scraper bar and within 16" of the outside extents of the disk width.

**30.** Install the light kit module. Run the cables between the lights and the module as per the tags on the module pigtails indicating right hand and left hand. Run the single cable from the module to the front of the disk.

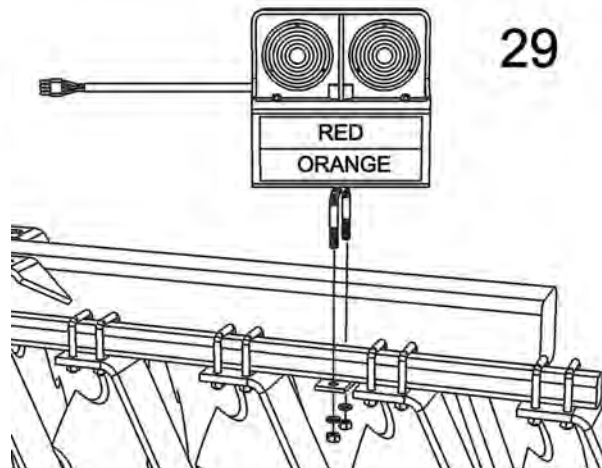
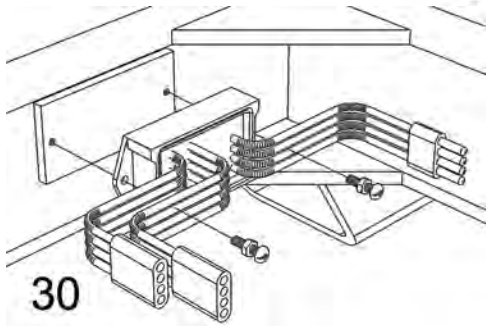
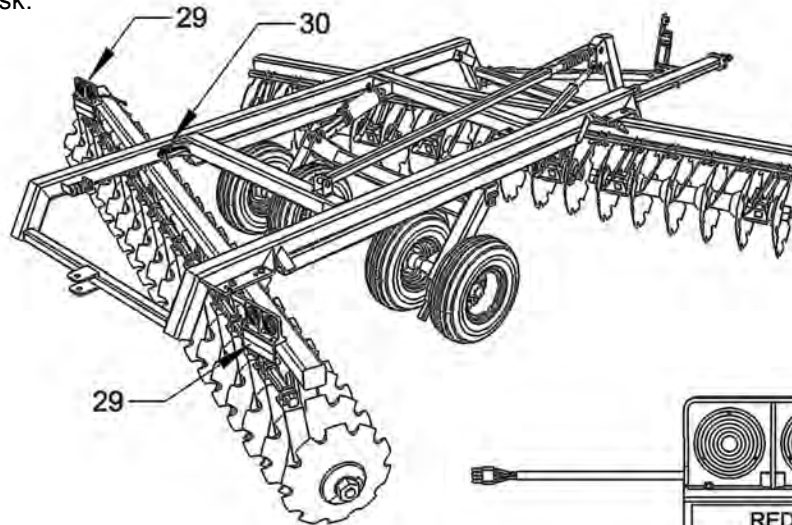

- Plug the light connector into the tractor receptacle and check for proper operation.
- Install the safety chain on the front of the hitch.
- Install the hose holder on hitch and clamp the hoses to the holder.
- If not already attached, hitch the disk to the tractor. Couple the hydraulic hoses to the tractor. Charge the hydraulic cylinder. It will be necessary to hold the hydraulic control open for a minute or two in order to completely fill the cylinder and extend the cylinder rod enough to remove the transport stay. Remove the transport stay and lift the disk up and down a number of times to purge the system of air and reveal any leaks. Replace the fluid removed from the tractor hydraulic system.
- Check all the safety decals are present and undamaged.



## Disk Gang Assembly Procedure (Rebuild Only)

A disk gang consists of an axle on which disk blades, spacer spools and bearings are mounted. The axle is threaded at each end. End washers are then placed on both ends of the axle. Heavy axle nuts are then threaded onto each end and tightened to a recommended torque. The axle nuts are locked into place by bolting a nut lock plate around or beside the nut and to the end washers with bolts and lock nuts. The disk blades, spacer spools and bearings have both concave and convex surfaces. Care must be taken to match convex with concave surfaces during assembly. End washers are either concave or convex and the appropriate washer should be placed at each end of the axle.

**⚠ CAUTION: Gang components are heavy. Two-person assembly is recommended. Follow Safety Guidelines.**

To assemble, install the convex end washer and nut on one end of the axle. Slide one blade concave side down onto the axle against the convex end washer. Next slide a bearing onto the axle, concave end first, against the disk blade. The axle can now be raised to the vertical position and it will stand without being held. In the upright position, the convex end washer should be snug against the underside of the disk blade. If necessary, tilt the axle and disk blade and place a spacer (eg. a length of 1" X 4" wood) between the nut and the floor or ground. This ensures the top threaded end of the axle will be exposed when the gang is completely stacked and the nut can be installed.

With the axle in the upright position, the remaining components can be stacked. Keep all the spacer spools between the bearings with the bearings in the outermost positions on the axle (excepting axles on which taper blades are mounted). While stacking the components, make sure all mating surfaces are free of dirt, rust, grease, grit or any other material that interferes with the mating surfaces. After the last disk is in place, drop the concave end washer into place. Apply an anti-seize compound to the axle threads and install the axle nut. Tighten the nut to remove as much slack as possible. Lower the entire assembly to the ground using hoist or forklift and chock both sides of the assembly to prevent it from rolling. Using the gang wrenches provided with the disk, tighten both axle nuts as tight as possible. It may be necessary to use a length of 2" pipe on the wrenches for extra leverage. A sledge hammer may be used to strike the wrench handle for the final adjustment to fit the nut lock plates. Install the nut lock plates over the axle nuts and attach to the end washer with the four bolts and lock nuts provided.

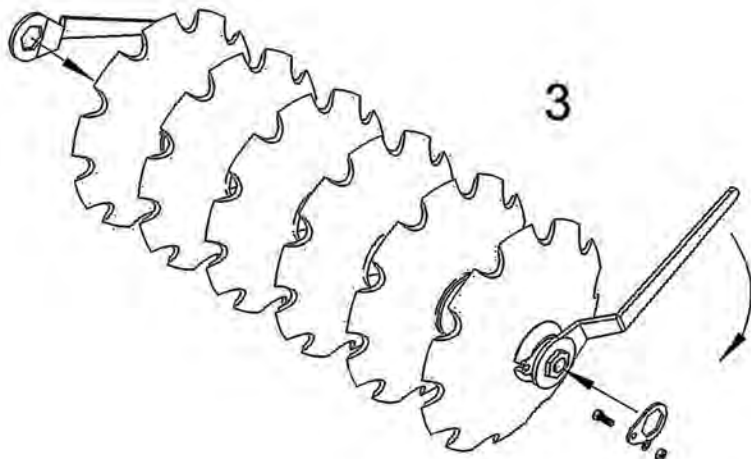
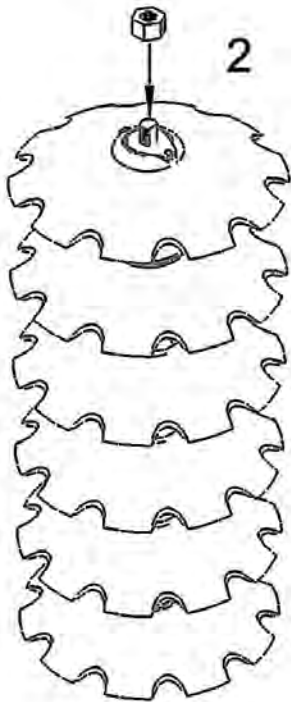
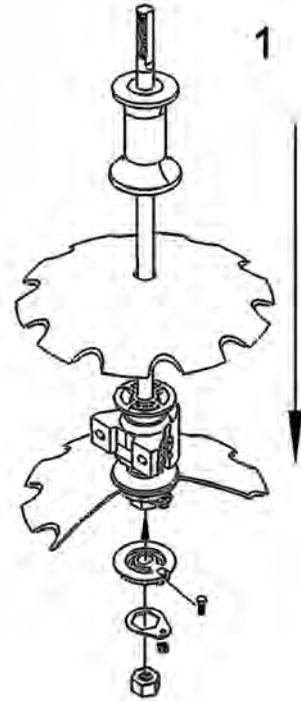

## Detailed Parts Diagrams

- The illustrated parts diagrams will assist in procuring replacement parts from your Frontier Dealer. However, to be sure of receiving the correct parts, please have the Model Number and Serial Number of your disk available when ordering parts.
  
- In the event the serial number plate is missing the following information can help to identify your disk:
  - the total number of disk blades on the unit.
  - the spacing in inches between the disc blades.
  
- The parts diagrams can also aid in the assembly and maintenance of your disk.

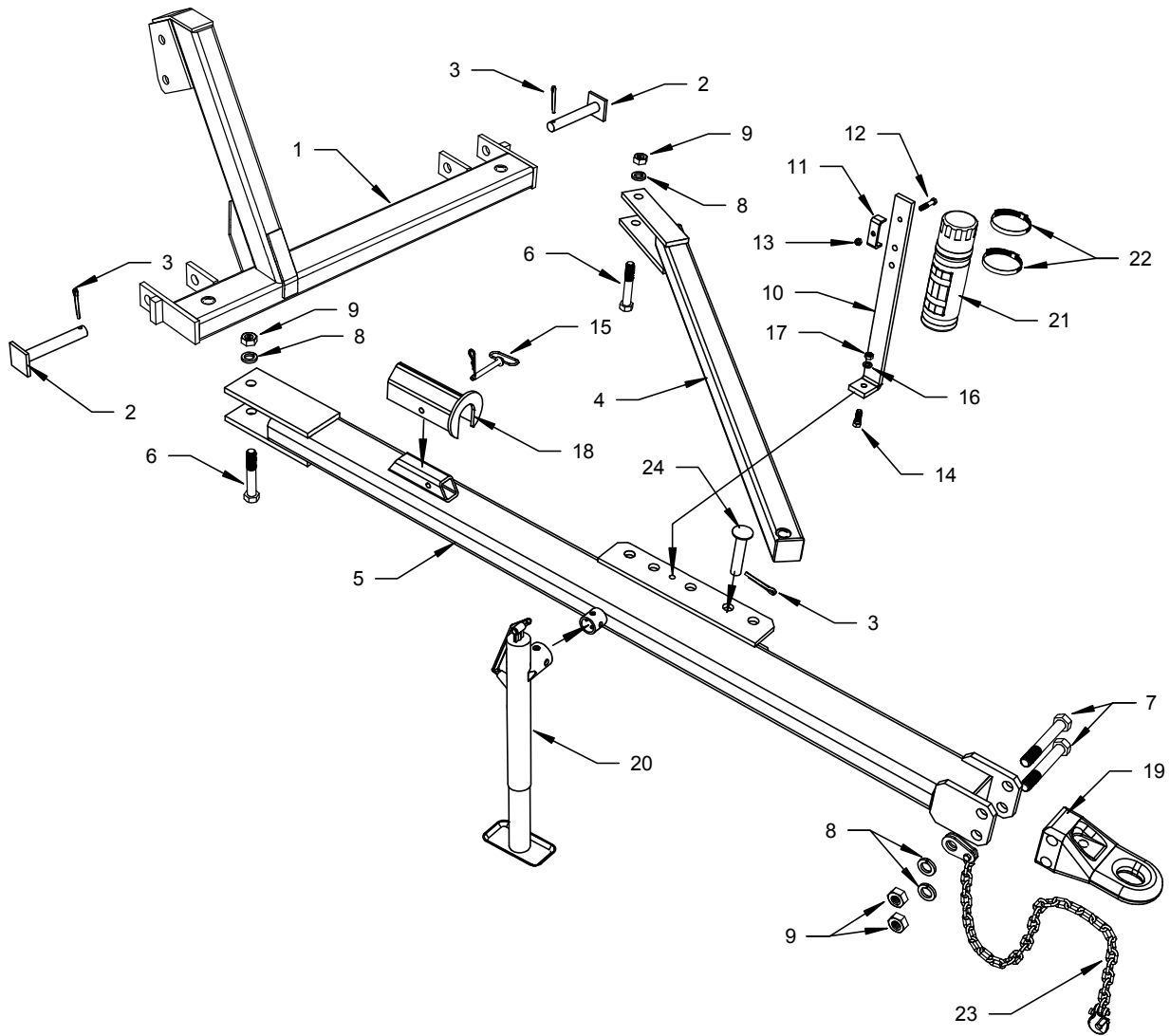

### Hitch and Bridle Assembly - Models DH5108 / DH5110 / DH5112

REF NO	PART NUMBER	DESCRIPTION	NO REQ'D
1	5KBK10270	Bridle	1
2	5KB3027222	Bridle Pin	2
3	5KB375300CP	Cotter Pin	3
4	5KBK10210	Side Arm	1
5	5KBK10120	Drawbar	1
6	5KB100600B8	1" X 6" UNC Hex Bolt	2
7	5KB100800B8	1" X 8" UNC Hex Bolt	2
8	5KBLW100	1" Lock Washer	4
9	5KBNC100	1" Hex Nut	4
10	5KB501064054	Hose Holder	1
11	5KBTBX50	Hose Clamp	1
12	5KB038200B5	3/8" X 2" UNC Bolt	1
13	5KBNC038L	3/8" Lock Nut	1
14	5KB050150B5	1/2" X 1-1/2" UNC Hex Bolt	1
15	5KB442160	Pin c/w Hair Pin	1
16	5KBLW050	1/2" Lock Washer	1
17	5KBNC050	1/2" Hex Nut	1
18	5KBCTS080	Transport Stay	1
19	5KBPP1301VH	Removable Hitch Tongue	1
20	5KBTBX8	Hitch Jack	1
21	5KBDOCH914	Operator's Manual Canister	1
22	5KBHAS64	Screw Band (Worm Gear) Clamp	2
23	5KBPPISC11A	Safety Chain (Cat I)	1
24	5KB3027199	Side Arm Pin	1

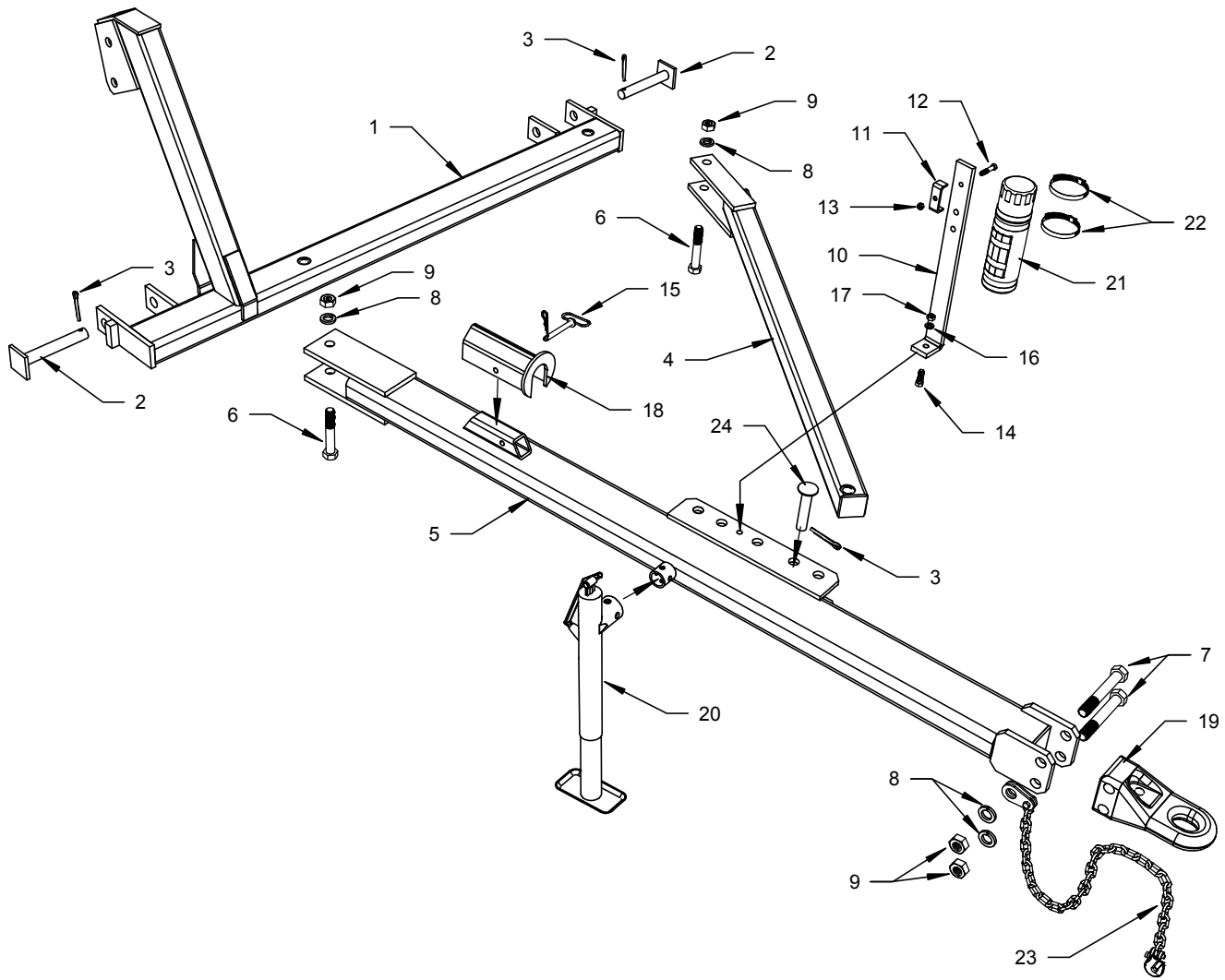

Hitch and Bridle Assembly - Models DH5114 / DH5116

REF NO	PART NUMBER	DESCRIPTION	NO REQ'D
1	5KBK10270W	Bridle	1
2	5KB3027222	Bridle Pin	2
3	5KB375300CP	Cotter Pin	3
4	5KBK10210W	Side Arm	1
5	5KBK10120W	Drawbar	1
6	5KB100600B8	1" X 6" UNC Hex Bolt	2
7	5KB100800B8	1" X 8" UNC Hex Bolt	2
8	5KBLW100	1" Lock Washer	4
9	5KBNC100	1" Hex Nut	4
10	5KB501064054	Hose Holder	1
11	5KBTBX50	Hose Clamp	1
12	5KB038200B5	3/8" X 2" UNC Bolt	1
13	5KBNC038L	3/8" Lock Nut	1
14	5KB050150B5	1/2" X 1-1/2" UNC Hex Bolt	1
15	5KB442160	Pin c/w Hair Pin	1
16	5KBLW050	1/2" Lock Washer	1
17	5KBNC050	1/2" Hex Nut	1
18	5KBCTS080	Transport Stay	1
19	5KBPP1301VH	Removable Hitch Tongue	1
20	5KBTBX8	Hitch Jack	1
21	5KBDOCH914	Operator's Manual Canister	1
22	5KBHAS64	Screw Band (Worm Gear) Clamp	2
23	5KBPP1SC11A	Safety Chain (Cat I)	1
24	5KB3027199	Side Arm Pin	1

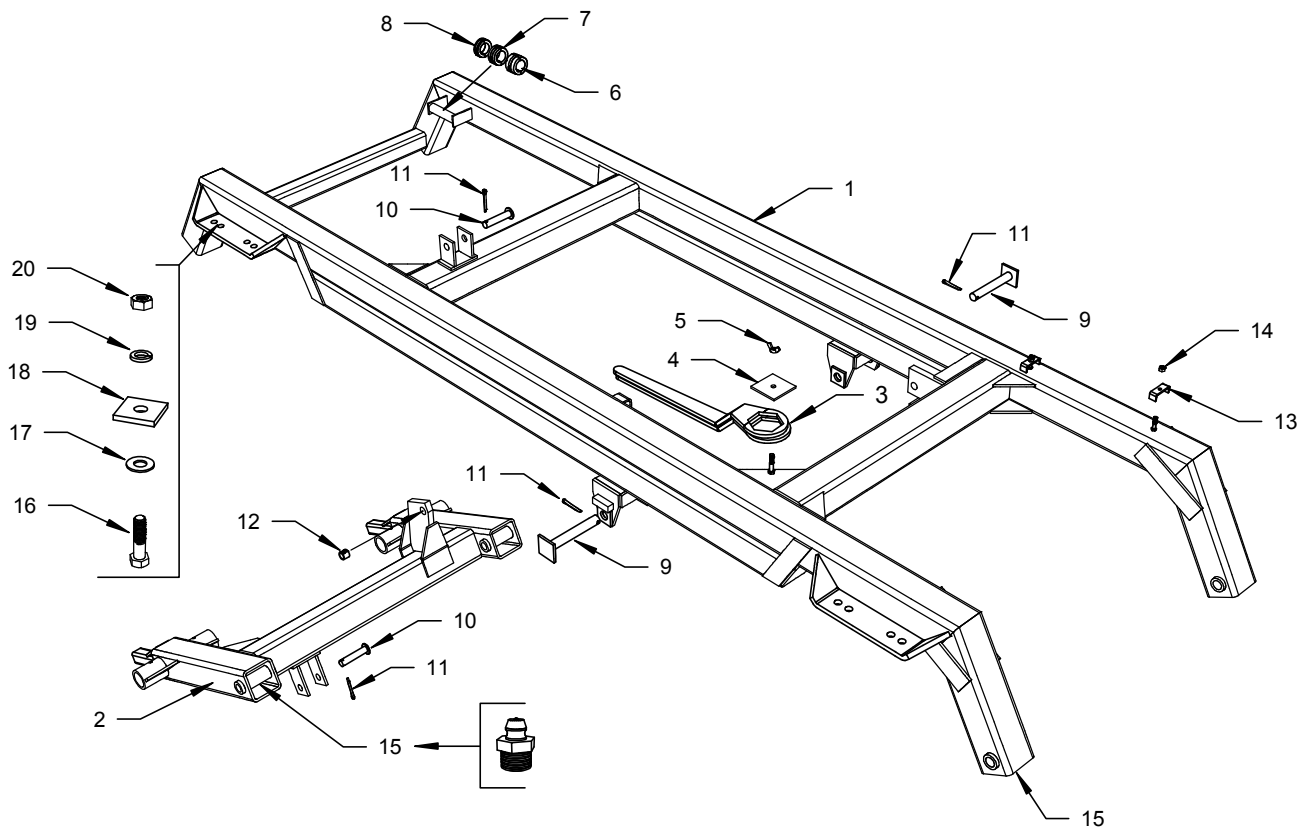

### Frame and Transport Assembly - Models DH5108 / DH5110 / DH5112

REF NO	PART NUMBER	DESCRIPTION	NO REQ'D
1	5KBK12050	Frame	1
2	5KBK13010	Transport	1
3	-see pages 41 or 42	Axle Wrench	2
4	5KB3043010	Hold Down Plate	1
5	5KBNC050W	1/2" UNC Wing Nut	1
6	5KB501045100	2" Rod Stop (Segment)	1
7	5KB501043688	1-1/2" Rod Stop (Segment)	1
8	5KB501043620	1" Rod Stop (Segment)	1
9	5KB3027270	Transport Pin	2
10	5KB3027209	Control Arm Pin	2
11	5KB375300CP	Cotter Pin	4
12	5KB125100100	Split Bushing	2
13	5KBTBX50	Hose Clamp	1
14	5KBNC0385L	3/8" Hex Lock Nut	1
15	5KB11100	Grease Zerk	4
16	5KB088350B8	7/8" UNC Grade 8 Hex Bolt	8
17	5KBFW088	7/8" Flat Washer	10
18	5KBSW088	Square Spacer Washer	4
19	5KBLW088	7/8" Lock (Spring) Washer	8
20	5KBNC088	7/8" UNC Grade 8 Hex Nut	8

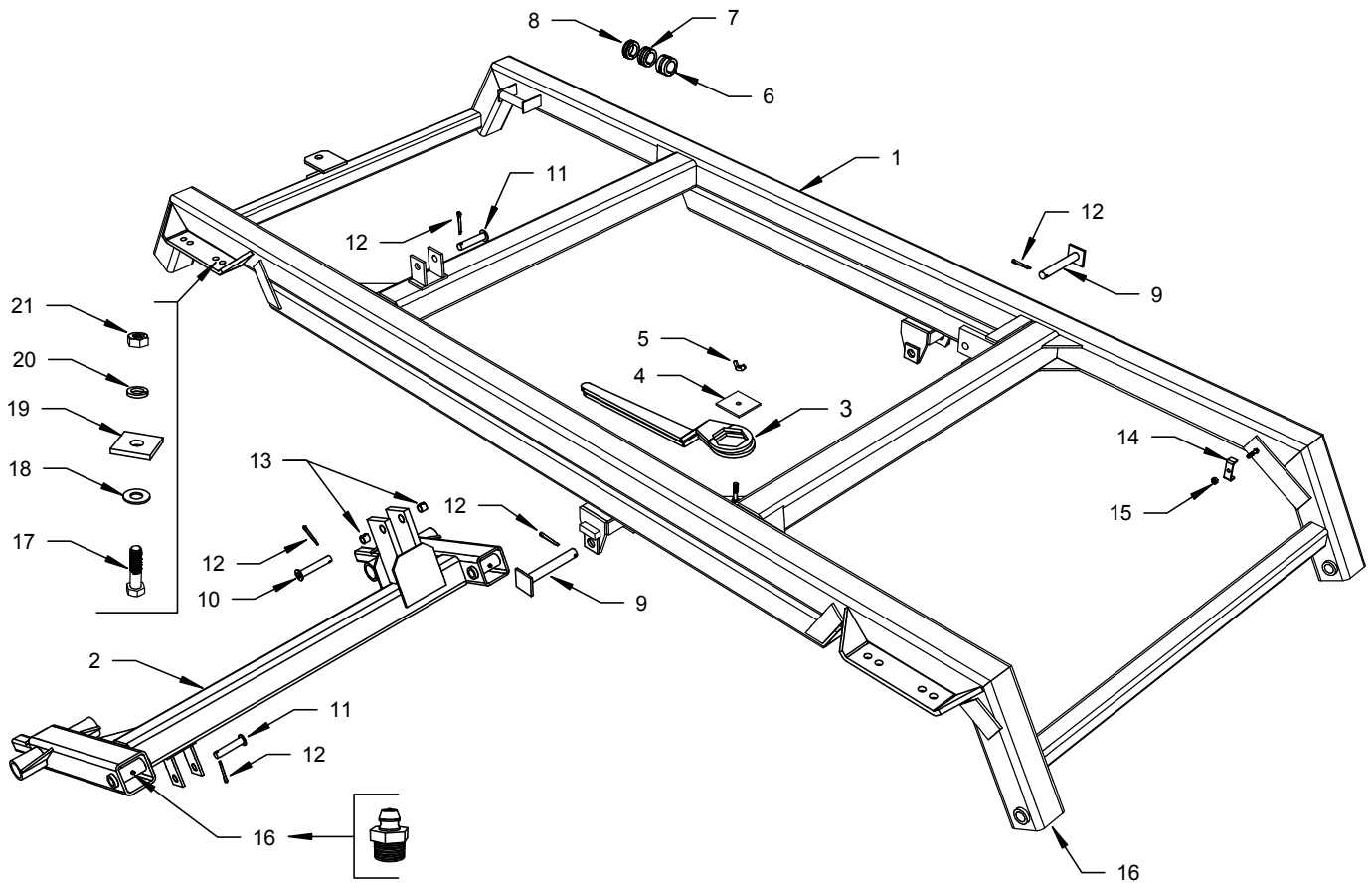

### Frame and Transport Assembly - Models DH5114 / DH5116

REF NO	PART NUMBER	DESCRIPTION	NO REQ'D
1	5KBK12050W	Frame	1
2	5KBK13010W	Transport	1
3	-see pages 41 or 42	Axle Wrench	2
4	5KB3043010	Hold Down Plate	1
5	5KBNC050W	1/2" UNC Wing Nut	1
6	5KB501045100	2" Rod Stop (Segment)	1
7	5KB501043688	1-1/2" Rod Stop (Segment)	1
8	5KB501043620	1" Rod Stop (Segment)	1
9	5KB3027270	Transport Pin	2
10	5KB3027211	Cylinder Pin	1
11	5KB3027209	Control Arm Pin	2
12	5KB375300CP	Cotter Pin	5
13	5KB125100100	Split Bushing	2
14	5KBTBX50	Hose Clamp	1
15	5KBNC0385L	3/8" Hex Lock Nut	1
16	5KB11100	Grease Zerk	4
17	5KB088350B8	7/8" UNC Grade 8 Hex Bolt	8
18	5KBFW088	7/8" Flat Washer	10
19	5KBSW088	Square Spacer Washer	4
20	5KBLW088	7/8" Lock (Spring) Washer	8
21	5KBNC088	7/8" UNC Grade 8 Hex Nut	8

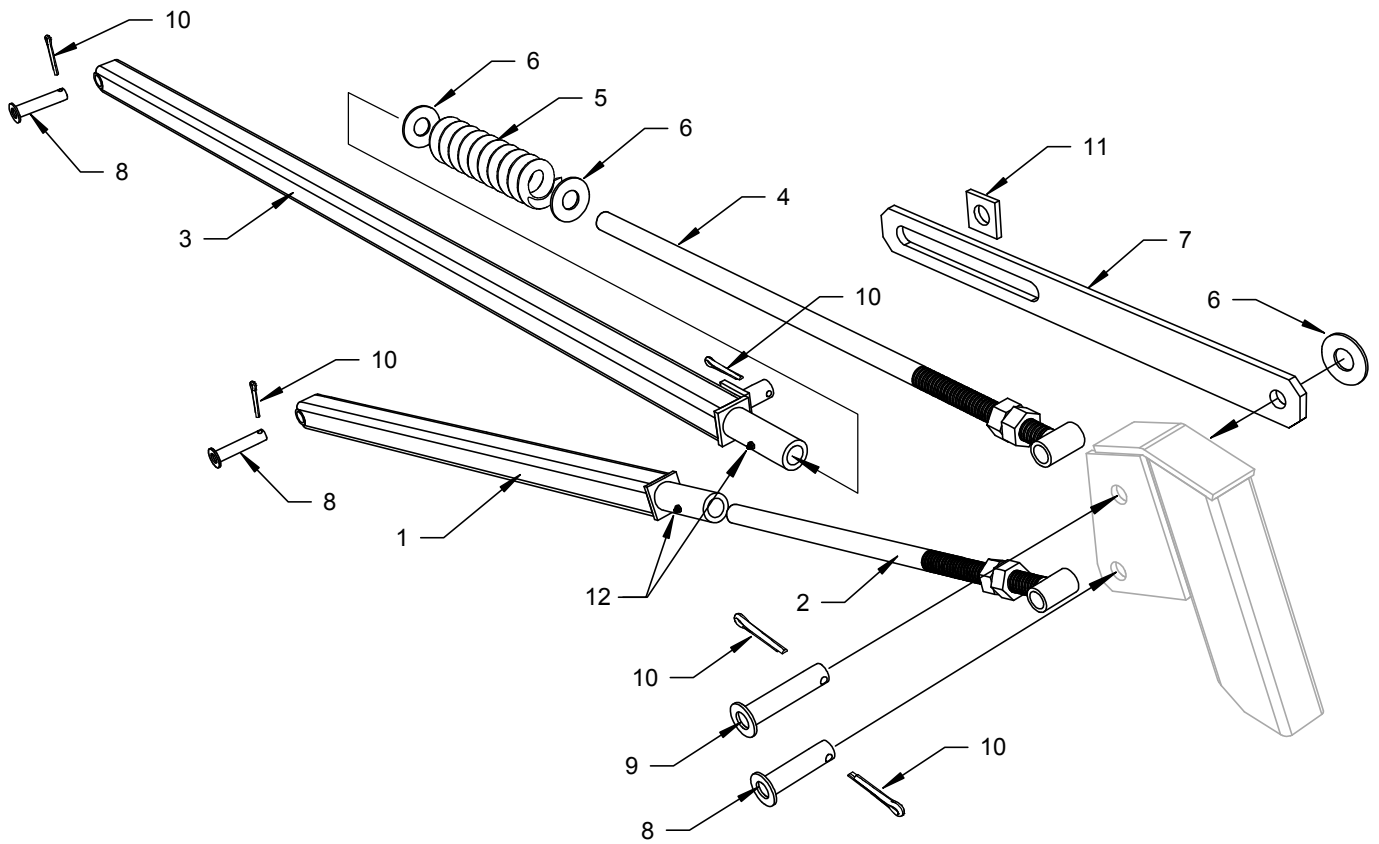

### Control Arm Assemblies - Models DH5108 / DH5110 / DH5112

REF NO	PART NUMBER	DESCRIPTION	NO REQ'D
1	5KBK13200	Transport Control Arm	1
2	5KBK13240	Transport Control Eyebolt	1
3	5KBK13110	Leveling Control Arm	1
4	5KBK13150	Leveling Control Eyebolt	1
5	5KB5004979	Compression Spring	1
6	5KBFW100	1" Flat Washer	3
7	5KB3050004	Slider	1
8	5KB3027209	Pin	3
9	5KB3027210	Pin	1
10	5KB375300CP	Cotter Pin	5
11	5KBSW125	Square Washer	1
12	5KB11100	Grease Zerk	2

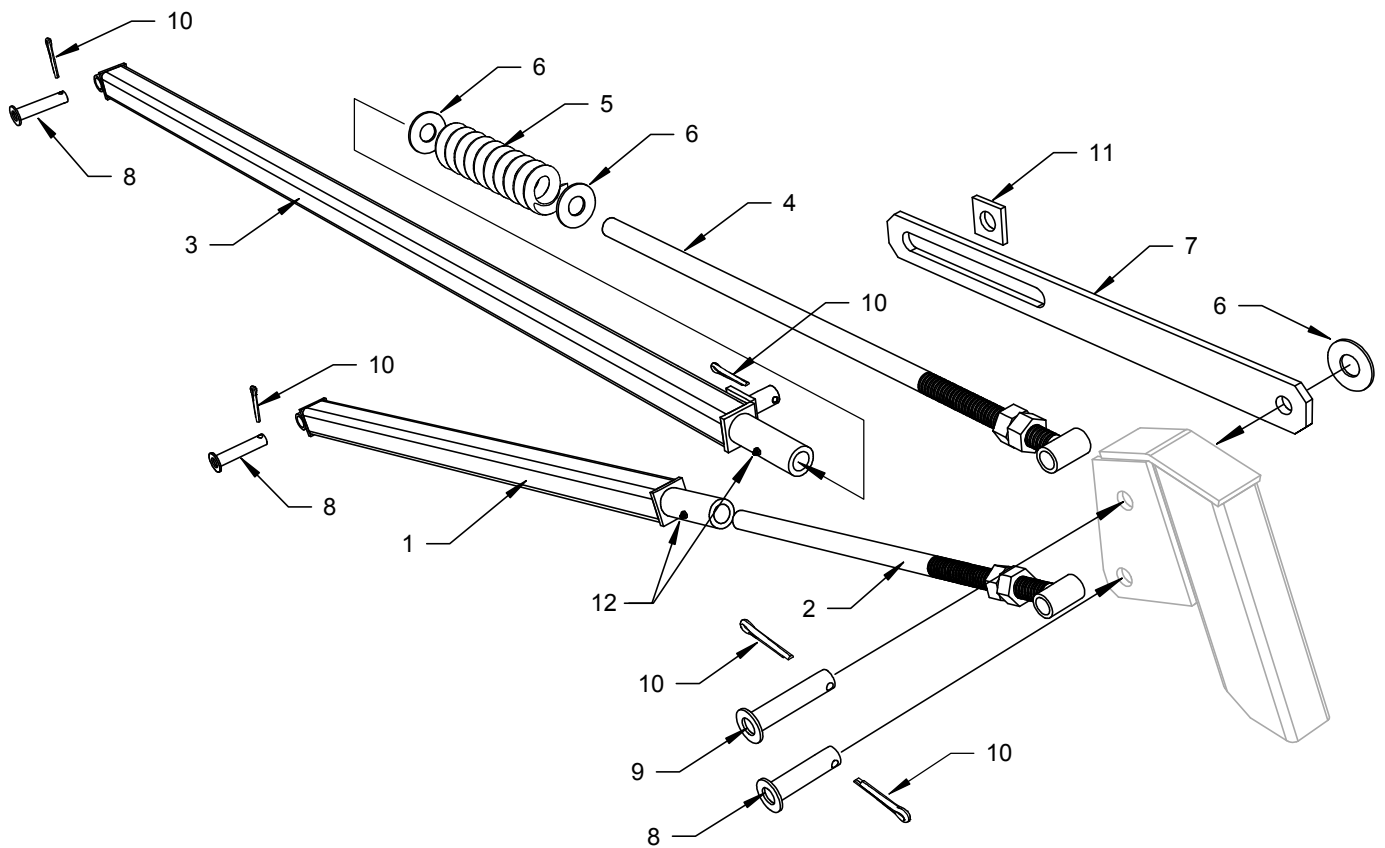

### Control Arm Assemblies - Models DH5114 / DH5116

REF NO	PART NUMBER	DESCRIPTION	NO REQ'D
1	5KBK13200W	Transport Control Arm	1
2	5KBK13240	Transport Control Eyebolt	1
3	5KBK13110W	Leveling Control Arm	1
4	5KBK13150	Leveling Control Eyebolt	1
5	5KB5004979	Compression Spring	1
6	5KBFW100	1" Flat Washer	3
7	5KB3050004	Slider	1
8	5KB3027209	Pin	3
9	5KB3027210	Pin	1
10	5KB375300CP	Cotter Pin	5
11	5KBSW125	Square Washer	1
12	5KB11100	Grease Zerk	2



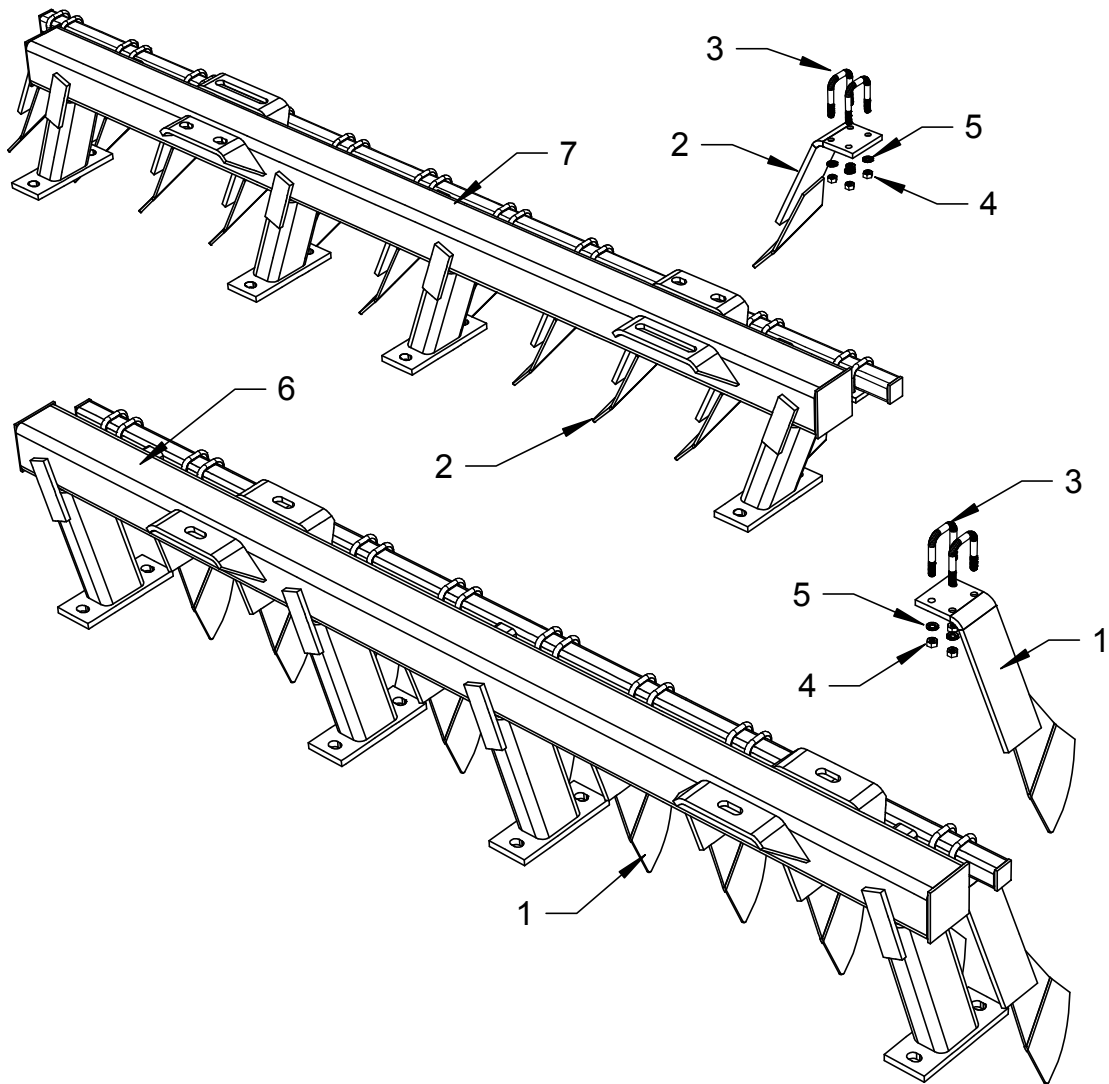

### Scrapers

REF NO	PART NUMBER	DESCRIPTION	NO REQ'D (per scraper)
1	5KB3043116	Right Hand Scraper	1
2	5KB3043097	Left Hand Scraper	1
3	5KB3027043	1/2" UNC U-Bolt	2
4	5KBNC050	1/2" UNC Hex Nut	4
5	5KBLW050	1/2" Lock Washer	4

### Gang Bars

MODEL	6 - FRONT GANG BAR		5KB3043116 Req'd	7 - REAR GANG BAR		5KB3043097 Req'd
	1-5/8" Axle	2-1/8" Axle		1-5/8" Axle	2-1/8" Axle	
DH5108	5KB20465	5KB20470	8	5KB21365	5KB21370	9
DH5110	5KB20535	5KB20540	10	5KB21425	5KB21430	11
DH5112	5KB20605	5KB20610	12	5KB21485	5KB21490	13
DH5114	5KB20675	5KB20680	15	5KB21545	5KB21550	16
DH5116	5KB20745	5KB20750	17	5KB21605	5KB21610	18

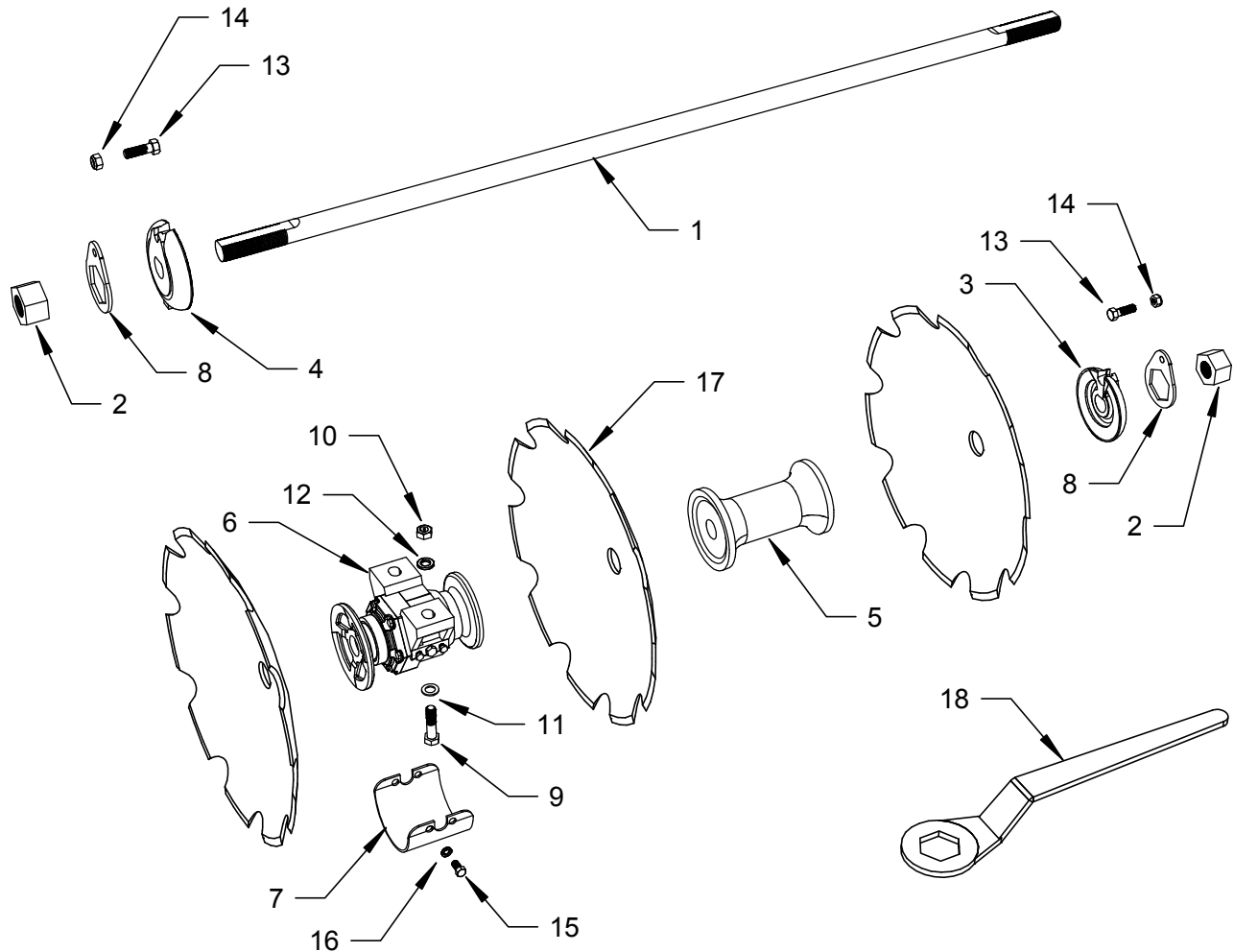

### Gang Assembly - 1-5/8" Axle

REF NO	PART NUMBER	DESCRIPTION	NO REQ'D (per assembly)
1	5KB501015028	Axle - 38.3" (4 Blades)	1
1	5KB501019016	Axle - 48.8" (5 Blades)	1
1	5KB501019012	Axle - 59.5" (6 Blades)	1
1	5KB501015631	Axle - 70.0" (7 Blades)	1
1	5KB501019015	Axle - 80.5" (8 Blades)	1
2	5KB502040640	Axle Nut	2
3	5KB502011048	Concave Axle Washer	1
4	5KB502011047	Convex Axle Washer	1
5	5KB502010703	Spacer Spool	Blades less 3
6	5KB501048765	Oil-Bath Bearing Assembly	2
7	5KB511010829	Bearing Wear Plate	2
8	5KB501018592	Axle Nut Lock	2
9	5KB075275B8	3/4" X 2-3/4" UNC Hex Bolt	4
10	5KBNC075	3/4" UNC Hex Nut	4
11	5KBFW075	3/4" Flat Washer	4
12	5KBLW075	3/4" Lock Washer	4
13	5KB063200B5	5/8" X 2" UNC Hex Bolt	2
14	5KBNC0635L	5/8" Lock Nut	2
15	5KB050075B8	1/2" X 3/4" UNC Hex Bolt	8
16	5KBLW050	1/2" Lock Washer	8
17	-see page 47	Disc Blades	
18	5KB2R81S	Axle Wrench	2

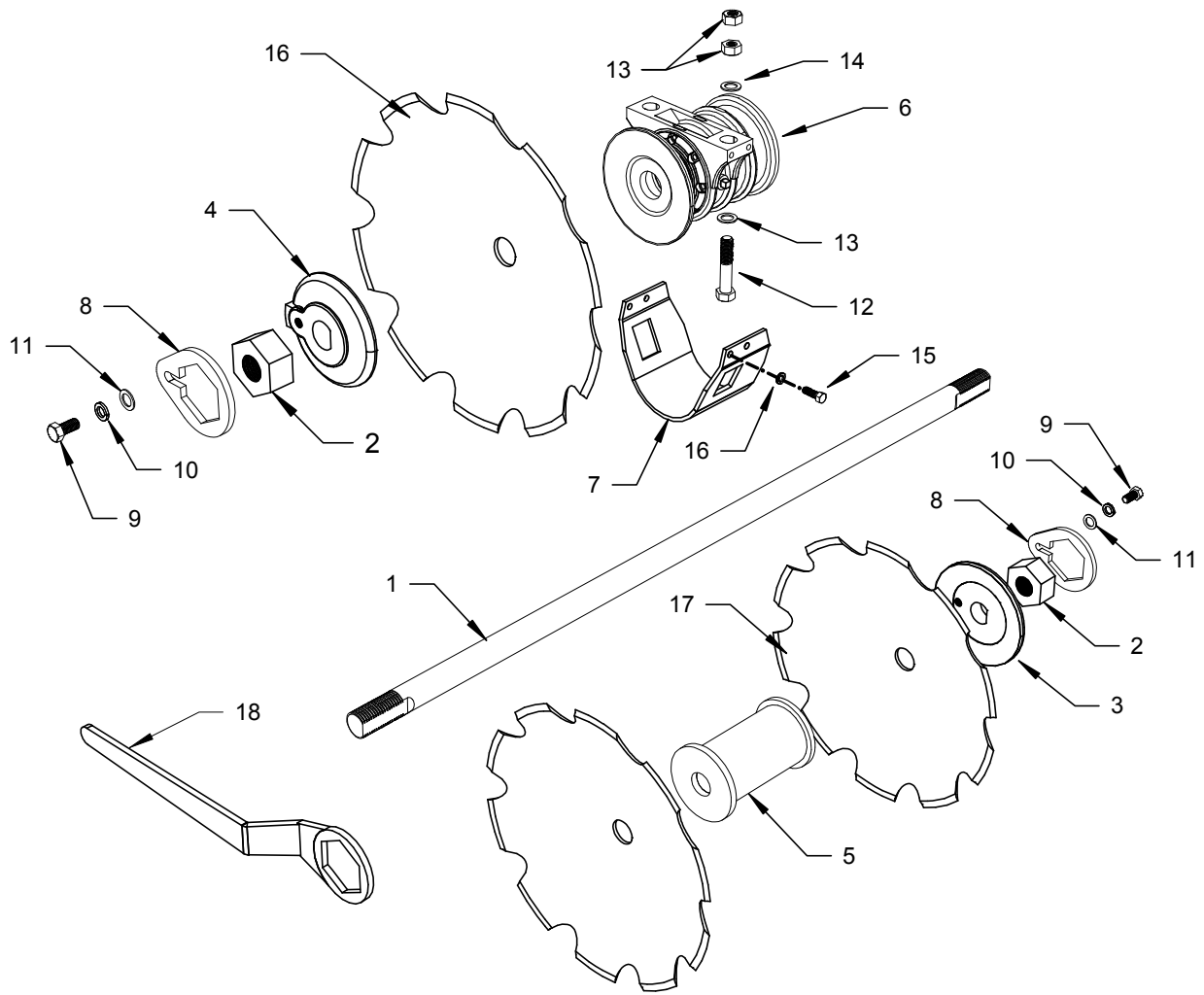

### Gang Assembly - 2-1/8" Axle

REF NO	PART NUMBER	DESCRIPTION	NO REQ'D (per assembly)
1	5KBKAH1AX	Axle - 39.5" (4 Blades)	1
1	5KBKAH2AX	Axle - 50.0" (5 Blades)	1
1	5KBKAH3AX	Axle - 60.5" (6 Blades)	1
1	5KBKAH4AX	Axle - 71.0" (7 Blades)	1
1	5KBKAH5AX	Axle - 81.5" (8 Blades)	1
2	5KB4N200	Axle Nut	2
3	5KB4A64B	Concave Axle Washer	1
4	5KB4A60C	Convex Axle Washer	1
5	5KBK27880	Spacer Spool	Blades less 3
6	5KB511048212	Oil-Bath Bearing Assembly	2
7	5KB511016371	Bearing Wear Plate	2
8	5KBNL225	Axle Nut Lock	2
9	5KB075175B8	3/4" X 1-3/4" UNC Hex Bolt	2
10	5KBLW075	3/4" Lock Washer	2
11	5KBFW075	3/4" Flat Washer	2
12	5KB088450B8	7/8" X 4-1/2" UNC Hex Bolt	4
13	5KBNC088	7/8" UNC Hex Nut	8
14	5KBFW088	7/8" Flat Washer	8
15	5KB050050B8	1/2" X 1/2" UNC Hex Bolt	8
16	5KBLW050	1/2" Lock Washer	8
17	- see page 47	Disc Blades	
18	5KB2R81	Axle Wrench	2

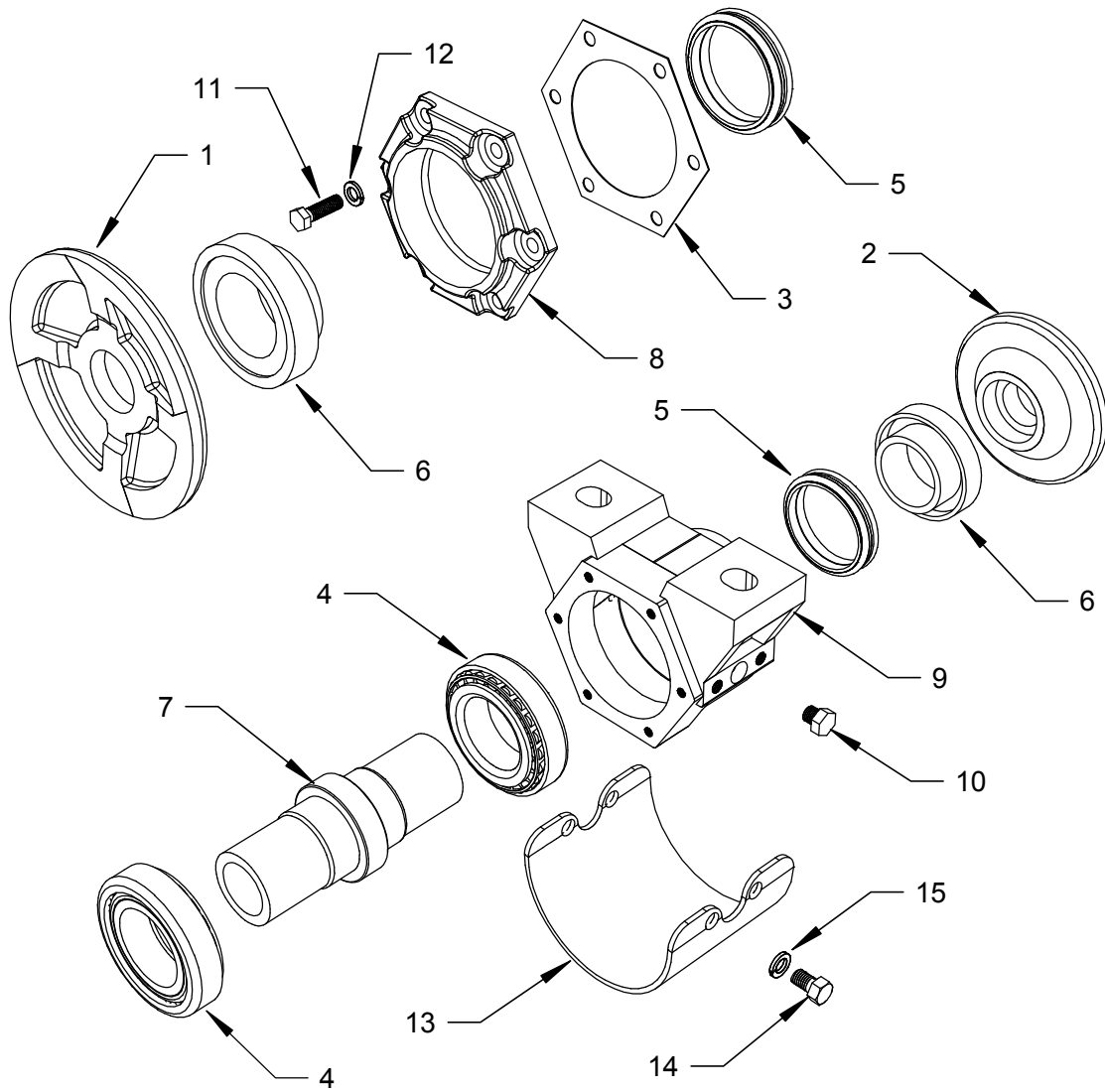

Oil-Bath Bearing Assembly - 5KB501048765 (1-5/8" Axle)

REF NO	PART NUMBER	DESCRIPTION	NO REQ'D
1	5KB524010480	Concave Flange	1
2	5KB524010479	Convex Flange	1
3	5KB533310042	Gasket / Shim	
4	5KB620350074	Bearing - Cup and Cone	2
5	5KB620010297	Duo-Cone Seal	2
6	5KB580010751	Seal Retainer	2
7	5KB580010680	Bearing Axial	1
8	5KB553814642	End Cap	1
9	5KB536810584	Bearing Housing	1
10	5KB581010007	Check Plug	2
11	5KB038125B	3/8" X 1-1/4" UNC Hex Bolt	6
12	5KBLW038	3/8" Lock Washer	6
13	5KB511010829	Bearing Wear Plate	2
14	5KB050075B	1/2" X 3/4" UNC Hex Bolt	4
15	5KBLW050	1/2" Lock Washer	4

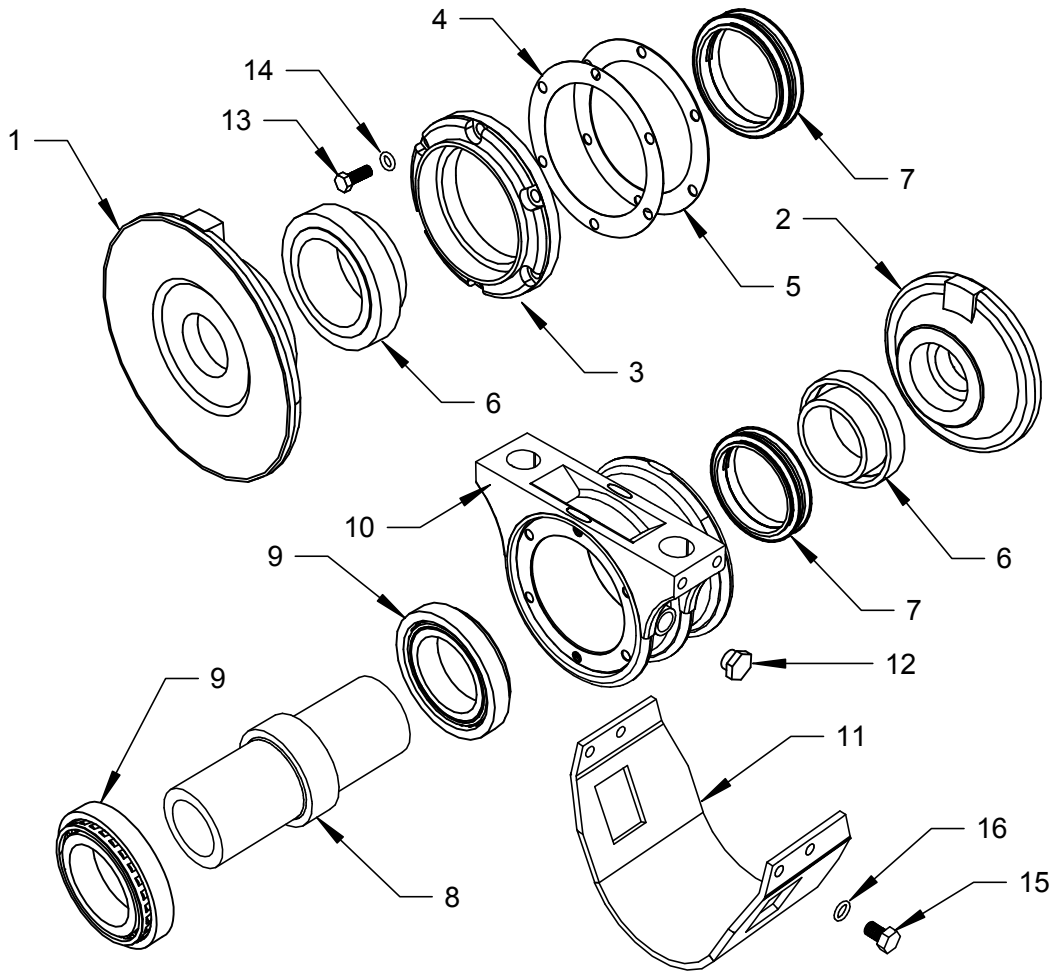

### Oil-Bath Bearing Assembly - 5KB511048212 (2-1/8" Axle)

REF NO	PART NUMBER	DESCRIPTION	NO REQ'D
1	5KB502040195	Inner Flange - Concave	1
2	5KB502040196	Outer Flange - Convex	1
3	5KB502010645	End Cap	1
4	5KB503030536	Gasket - 0.4mm (Preload Shim)	
5	5KB503030686	Gasket - 0.1mm (Preload Gasket)	
6	5KB561014959	Seal Retainer	2
7	5KB503030028	Duo-Cone Seal	2
8	5KB561014958	Bearing Axial	1
9	5KB503010117	Bearing Cup and Cone	2
10	5KB502012618	Bearing Housing	1
11	5KB511016371	Wear Plate	1
12	5KB503010856	Check Plug	2
13	5KB038125B5	3/8" X 1-1/4" UNC Hex Bolt	6
14	5KBLW038	3/8" Lock Washer	6
15	5KB050075B8	1/2" X 3/4" UNC Hex Bolt	4
16	5KBLW050	1/2" Lock Washer	4

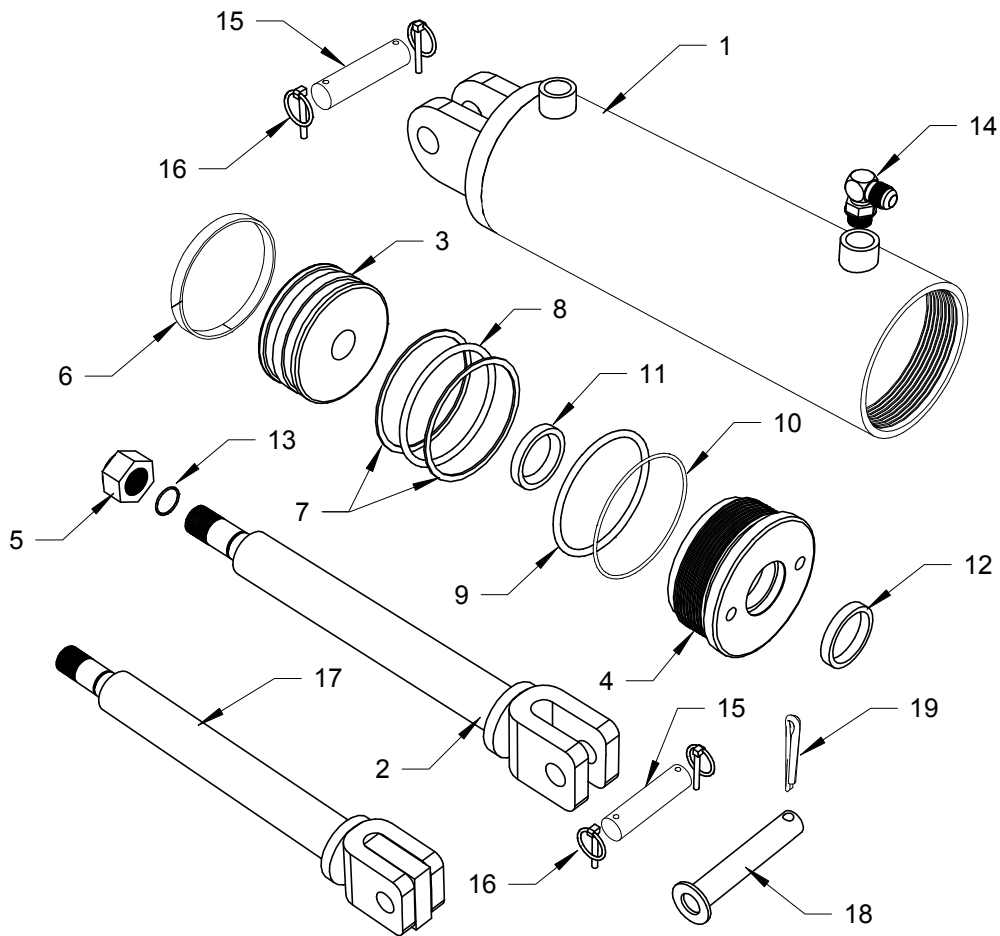

## 8" Hydraulic Cylinder - 5004971

(CTD - Canadian Tool & Die - C50-155A)

REF NO	PART NUMBER	DESCRIPTION	NO REQ'D (per assembly)
1	5KB5005018	Barrel	1
2	5KB5005015	Rod	1
3	5KB5005032	Piston	1
4	5KB5005022	Gland	1
5	5KB5005014	Locknut	1
6		Wear Ring	1
7		Back-up Ring	2
8		O-Ring (white)	1
9		O-Ring (black)	1
10		O-Ring (white)	1
11		Rod Seal (blue)	1
12		Rod Wiper	1
13		O-Ring	1
14	5KB5000611	90 deg Elbow Fitting	2
15	5KB3043581	Pin	1
16	5KB3043581CP	Click Pin	1
17	5KB5005015R	Rod - Models 225- 332_B / 225-372_B	2
18	5KB3027211	Pin - Models 225- 332_B / 225-372_B	1
19	5KB375300CP	Cotter Pin	1
	5KBSKC5086AK	Seal Kit (Nos. 6,7,8,9,10,11,12,13)	

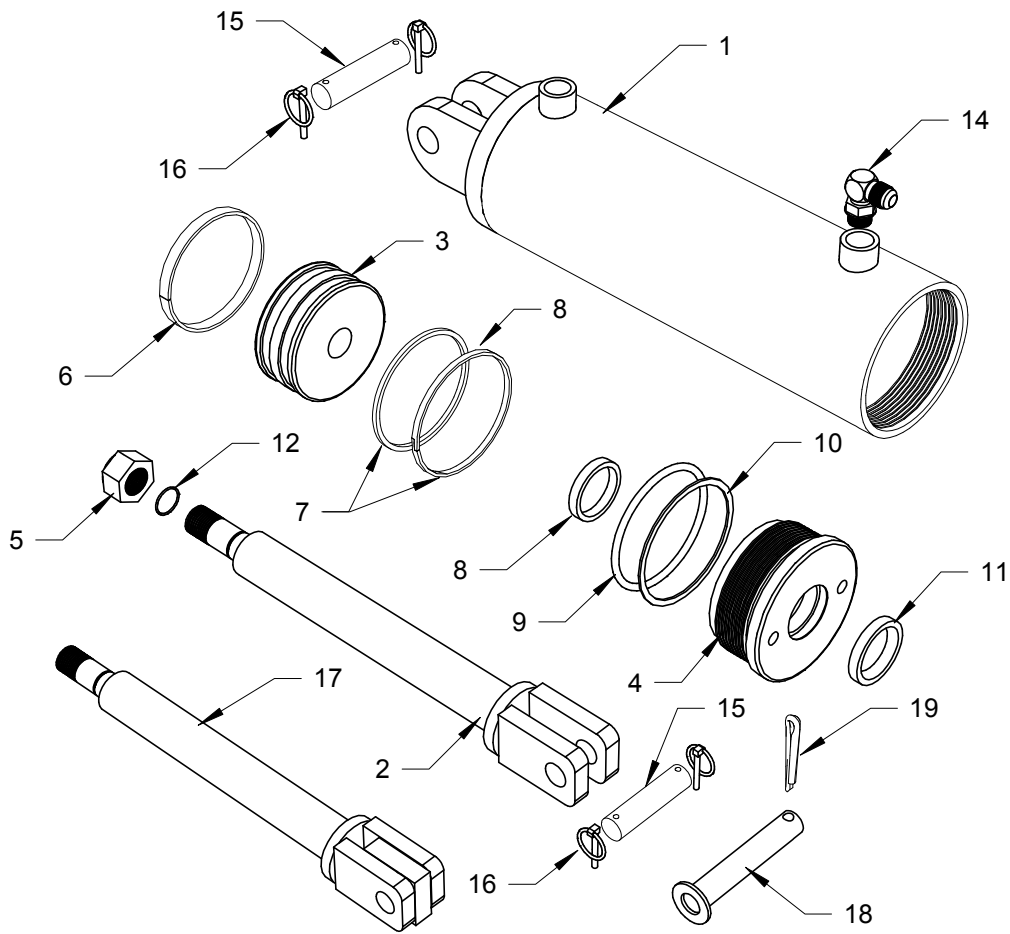





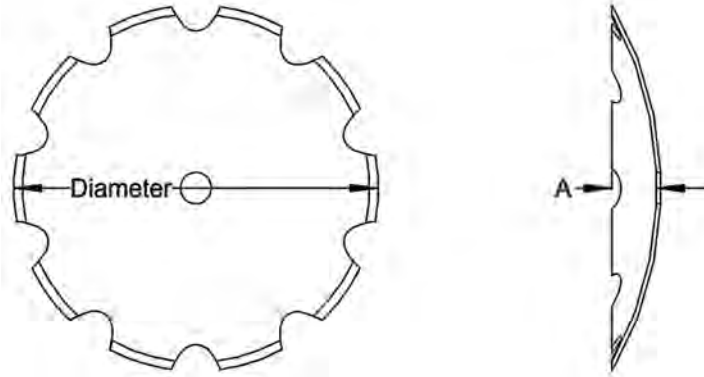

## 8" Hydraulic Cylinder - R4507782

(RAM Industries - R4507782)

REF NO	PART NUMBER	DESCRIPTION	NO REQ'D (per assembly)
1	5KBR5507782	Barrel	1
2	5KBR4207782	Rod	1
3	5KBR4607782	Piston	1
4	5KBR4707782	Gland	1
5	5KBR3005009	Locknut	1
6		Wear Ring	1
7		Piston Seal (2 piece)	1
8		Rod Seal	1
9		O-Ring	1
10		Back-up Ring	1
11		Rod Wiper	1
12		O-Ring	1
13	5KB5000611	90 deg Elbow Fitting	2
14	5KB3043581	Pin	1 - 2
15	5KB3043581CP	Click Pin	2 - 4
16	5KBR4207782R	Rod - Models 225- 332 _B / 225-372 _B	1
17	5KB3027211	Pin - Models 225- 332 _B / 225-372 _B	1
18	5KB375300CP	Cotter Pin	1
19	5KBR3607782	Seal Kit (Nos. 6,7,8,9,10,11,12)	

## Disc Blades



	Diameter	1-11/16 Center Hole	A	2-3/16 Center Hole	A
<b>Smooth Standard Concavity</b> 	22" X 1/4"	5KB029186S		5KB3186S	
	24" X 5/16"	5KB030378S		5KB3185S	
	26" X 5/16"	5KB033060S	3 3/4"	5KB3184S	3 3/4"
	28" X 5/16"	5KB037152S	4 5/16"	5KB3183S	4 5/16"
<b>Smooth Shallow Concavity</b> 	22" X 1/4"	5KB029186SLC		5KB3186SLC	
	24" X 5/16"	5KB030378SLC		5KB3185SLC	
	26" X 5/16"	5KB033060SLC	2 3/4"	5KB3184SLC	2 3/4"
	28" X 5/16"	5KB037152SLC	3 1/8"	5KB3183SLC	3 1/8"
<b>Notched Standard Concavity</b> 	22" X 1/4"	5KB029186		5KB3186	
	24" X 5/16"	5KB030378		5KB3185	
	26" X 5/16"	5KB033060	3 3/4"	5KB3184	3 3/4"
	28" X 5/16"	5KB037152	4 5/16"	5KB7148	4 5/16"
<b>Notched Shallow Concavity</b> 	22" X 1/4"	5KB029186LC		5KB3186LC	
	24" X 5/16"	5KB030378LC		5KB3185LC	
	26" X 5/16"	5KB033060LC	2 3/4"	5KB3184LC	2 3/4"
	28" X 5/16"	5KB037152LC	3 1/8"	5KB7148LC	3 1/8"
<b>Wavy</b> 	22" X 1/4"	5KB029304W		5KB3186W	
	24" X 5/16"	5KB30378W		5KB3185W	
	26" X 5/16"	5KB33060W		5KB3184W	
	28" X 5/16"	5KB37152W		5KB3183W	



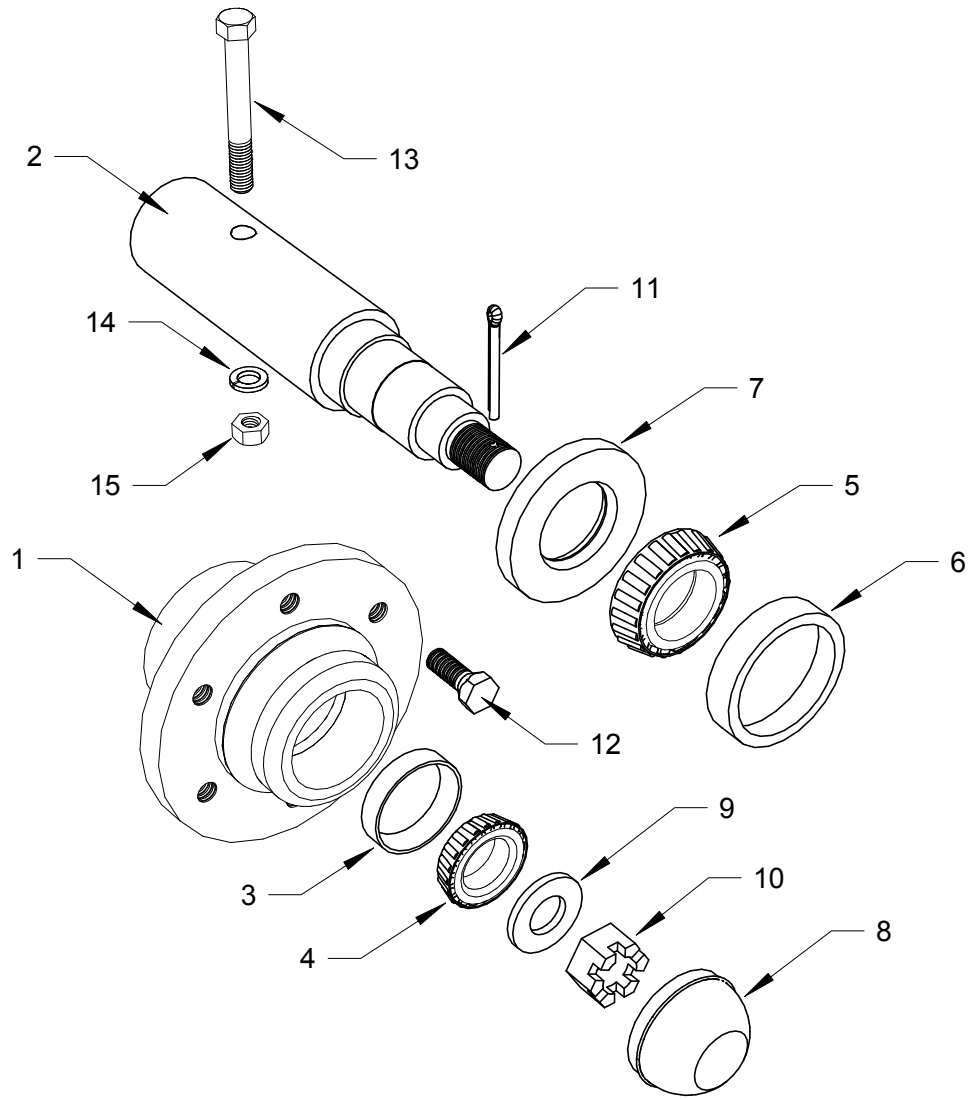

### 6-Bolt Hub - 5KB3027307

REF NO	PART NUMBER	DESCRIPTION	NO REQ'D (per assembly)
1	5KBH614	Hub	1
2	5KB3043128	Spindle	1
3	5KBLM48510	Outer Cup	1
4	5KBLM48548	Outer Cone	1
5	5KBLM603049	Inner Cone	1
6	5KBLM603011	Inner Cup	1
7	5KB5004991	Seal	1
8	5KBDC15	Dust Cap	1
9	5KBFW100	1" Hardened Flat Washer	1
10	5KBNF100S	1" Slotted Hex Nut	1
11	5KBCK019150	Cotter Key	1
12	5KBWB12	Wheel Bolt	6
13	5KB050400B5	1/2" X 4" UNC Hex Bolt	1
14	5KBLW050	1/2" Lock Washers	1
15	5KBNC050	1/2" UNC Hex Nut	1

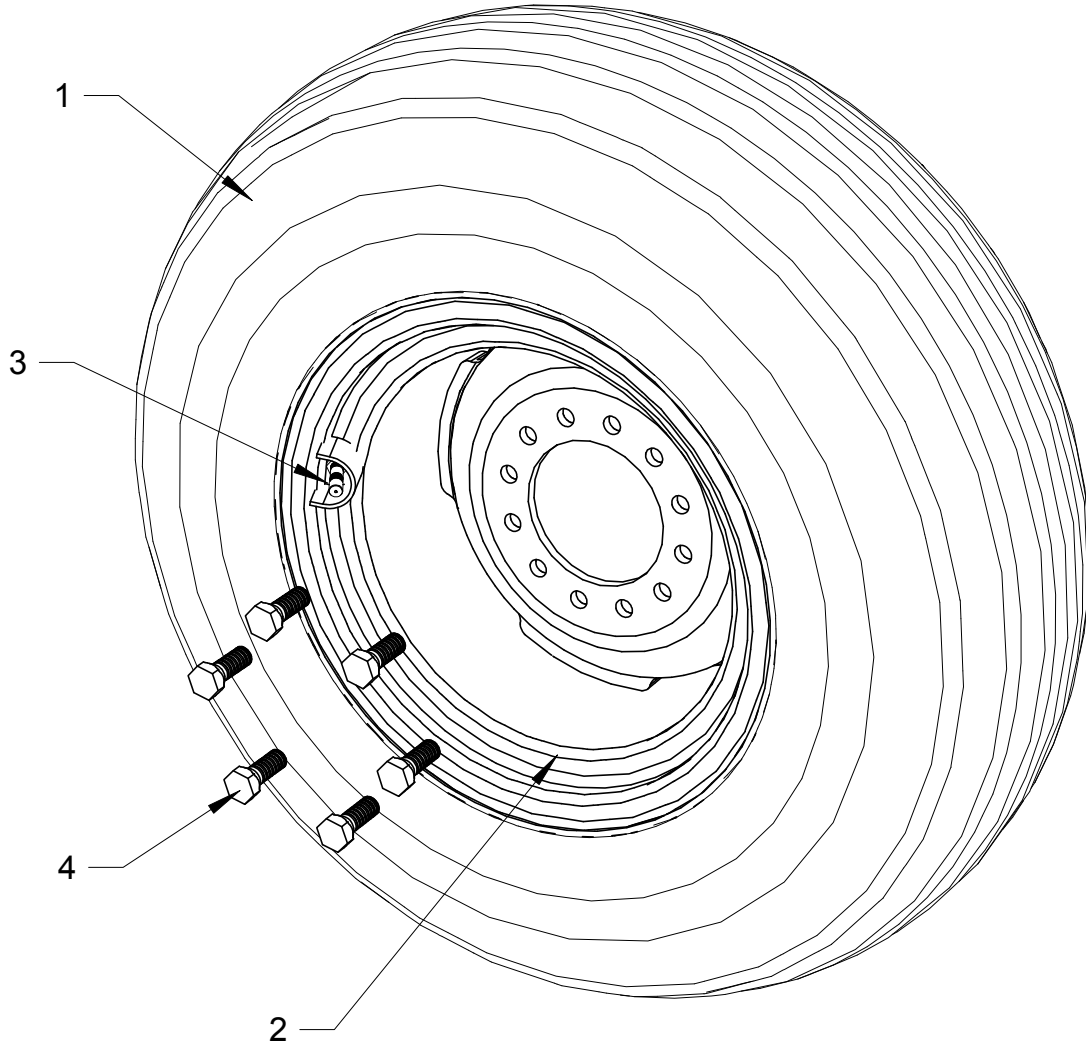





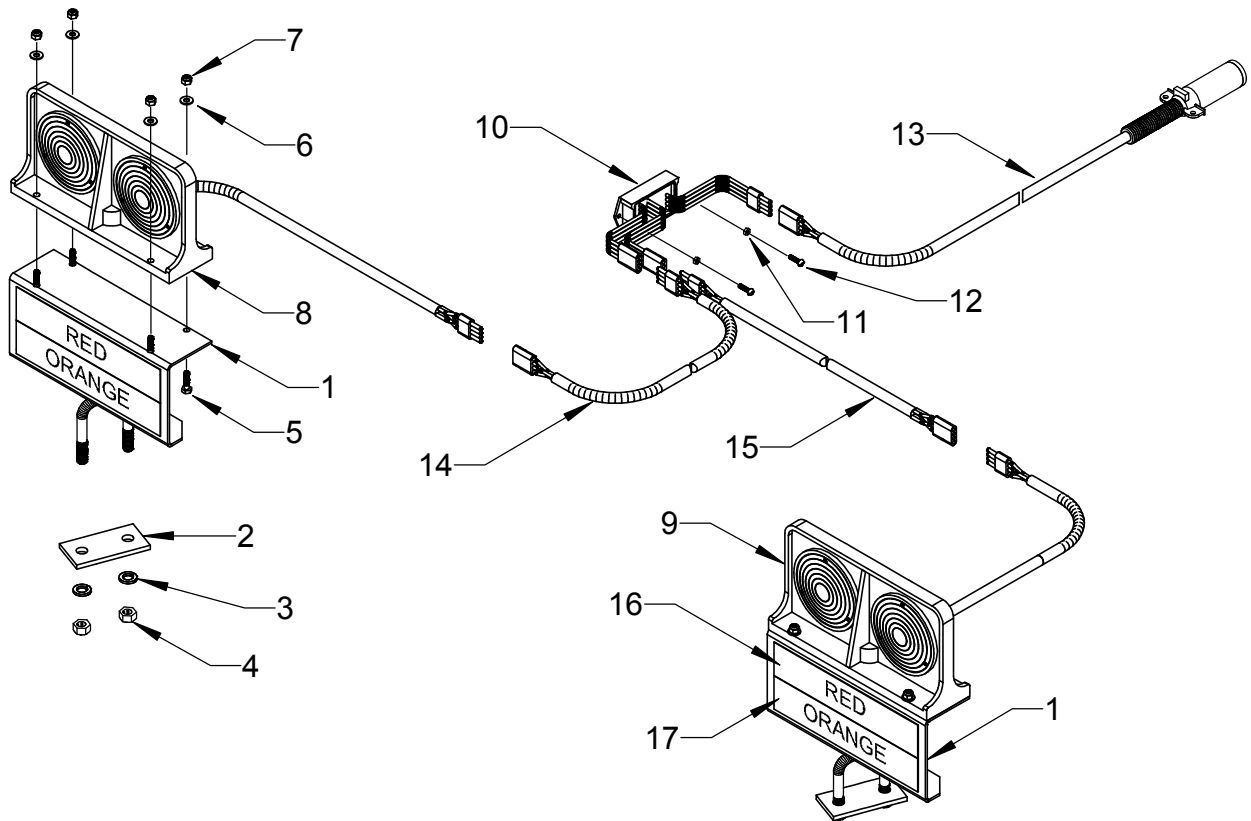



### Tire and Wheel Assembly

REF NO	PART NUMBER	DESCRIPTION	NO REQ'D
1	5KB5004994	Implement Tire	1
2	5KB5002632G	6 Bolt Steel Wheel	1
3	5KB5002632VS	Valve Stem	1
4	5KBWB12	Wheel Bolt	6

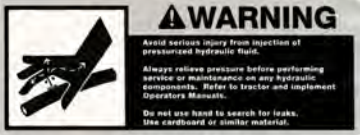

## Light Kit

REF NO	PART NUMBER	DESCRIPTION	NO REQ'D
1	5KB2250050	Light Mount	2
2	5KB2250051	Clamp Plate	2
3	5KBLW050	1/2" Lock Washer	4
4	5KBNC050	1/2" Hex Nut	4
5	5KB025100B5	1/4" X 1" UNC Bolt	8
6	5KBFW025	1/4" Flat Washer	8
7	5KBNC0255L	1/4" Nylon Lock Nut	8
8	5KB9212LBW	Left Light Set	1
9	5KB9212RBW	Right Light Set	1
10	5KBML246W	Module	1
11	5KBMN1024	No. 10-24 Machine Nut	2
12	5KBMS1024100	No. 10-24 Machine Screw	2
13	5KBLGMN26	Primary Cable - Models DH5108/DH5110/DH5112	1
13	5KBLGMN30	Primary Cable - Models DH5114/DH5116	1
14	5KBLGWDAL3	Left Intermediate Cable - Fits Models: DH5108 / DH5110 / DH5112	1
14	5KBLGWDAL4	Left Intermediate Cable - Fits Model DH5114	1
14	5KBLGWDAL5	Left Intermediate Cable - Fits Model DH5116	1
15	5KBLGWDAR7	Right Intermediate Cable - Fits Models: DH5108 / DH5110	1
15	5KBLGWDAR9	Right Intermediate Cable - Fits Model DH5112	1
15	5KBLGWDAR10	Right Intermediate Cable - Fits Model DH5114	1
15	5KBLGWDAR11	Right Intermediate Cable - Fits Model DH5116	1
16	5KB456DRR	Red Reflector Strip	2
17	5KB456DOR	Orange Reflector Strip	2

1. 
2. 
3. 
4. 
5. 
6. 
7. 
8. 
9. 
10. 

## Decals, Reflectors and Logos

REF NO	PART NUMBER	DESCRIPTION	NO REQ'D
1	5KBSM2FT	Frontier Logo	2
2	5KBDH5108	Model Logo for DH5108	2
	5KBDH5110	Model Logo for DH5110	2
	5KBDH5112	Model Logo for DH5112	2
	5KBDH5114	Model Logo for DH5114	2
	5KBDH5116	Model Logo for DH5116	2
3	5KBRFLYW	Yellow Reflector	6
4	5KBRFLRD	Red Reflector	2
5	5KBRFLOR	Orange Reflector	2
6	5KBDWPHF	WARNING – Avoid serious injury from injection of pressurized....	1
7.	5KBDCASI	CAUTION – To Avoid Serious Injury: .....	1
8.	5KBDDNA	DANGER – To avoid injury or death, do not adjust.....	1
9.	5KBDWMTS	WARNING – Do not exceed implements maximum transport...	1
10.	5KBDWICL	WARNING – Avoid serious injury from crushing or .....	1

# Specifications

## STANDARD EQUIPMENT AND FEATURES

- Oil-Bath Bearings with back-to-back tapered roller bearings in a ductile cast housing sealed with metal industrial cone seals. Two bearings per disk gang assembly.
- Replaceable bearing wear plates.
- Adjustable disk blade scrapers.
- 1-5/8" diameter alloy gang axles threaded at each end (optional 2-18" axle).
- Fabricated steel spacer spools.
- Separate transport levelling and field levelling mechanisms simplify adjustment.
- Hydraulic control group includes 8" stroke welded 5" diameter hydraulic cylinder with 2" rod, hose holder, hoses with fittings and quick disconnects to reach tractor couplers.
- 9.5L-15 Highway Service implement tires on 6-bolt wheels and hubs.
- Major fasteners minimum Grade 8 plated.
- Two fabricated steel gang axle wrenches.
- Hitch jack, safety chain and transport stay.
- Safety decals, mounted SMV sign and Light Kit

MODEL	Cut Width	Trans Width (A)	Blade Size	No of Blades	Blade Spacing	Weight - lbs	D.B.H.P.*
DH5108	8'	10' 2"	5/16" X 28"	19	10.5"	5500	80+
DH5110	10'	11' 9"	5/16" X 28"	23	10.5"	5925	90+
DH5112	12'	13' 4"	5/16" X 28"	27	10.5"	6365	110+
DH5114	14'	15' 2"	5/16" X 28"	33	10.5"	7700	140+
DH5116	16'	16' 9"	5/16" X 28"	37	10.5"	8500	160+

\* Drawbar Horsepower requirements vary with soil conditions, topography, weight added to the disk and tractor type (e.g. rubber track, rubber wheel, straight frame, articulated).

**Note:** The manufacturer reserves the right to make improvements and modifications which may, without notice, change these specifications.

DH5108  
DH5110  
DH5112

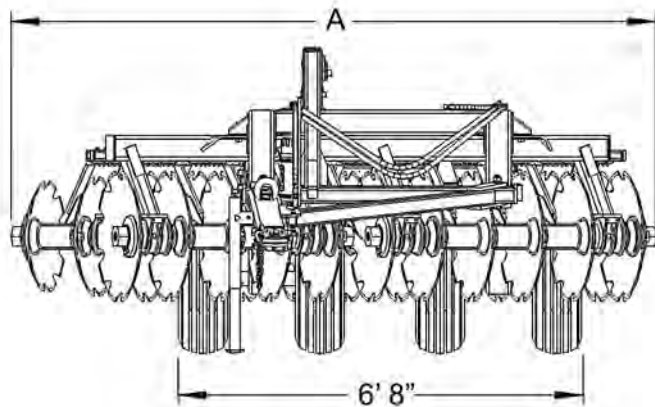

DH5114  
DH5116

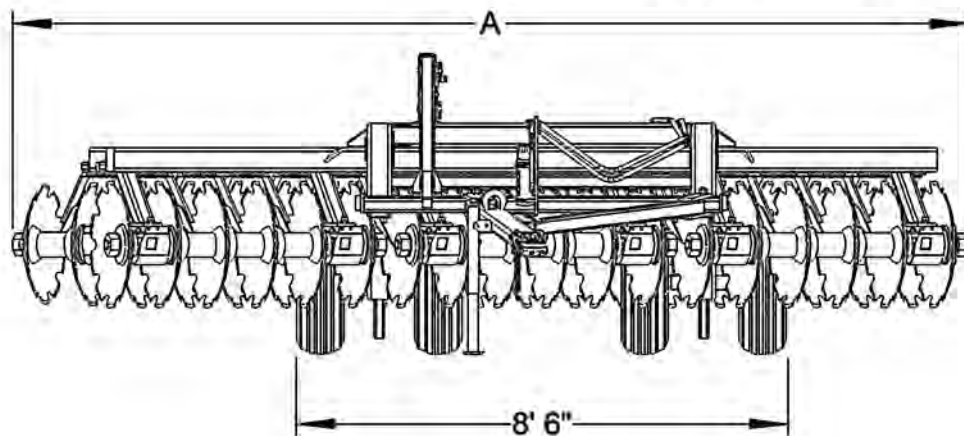

## Storage

At the end of the season and when putting the disk into storage:

- Clean dirt and debris from around moving parts and from the top of the frame, gang bars, hitch and bridle.
- Pay special attention to cleaning the area around the bearings. Spray a light coating of oil or rust preventative around the seal area of the bearings.
- Lubricate all grease fittings to prevent moisture infiltration.
- It is recommended to park with the disk in the raised position, coat the exposed hydraulic cylinder rod with grease, install the transport stay and relieve the hydraulic pressure. Place a block under the hitch jack to prevent it from sinking into the ground and be sure the tires are properly inflated. Chock the tires front and rear.
- Clean disk blades to minimize rust.
- Coat the quick disconnects in grease and wrap in plastic to prevent rust.
- Make a final inspection for worn, damaged or missing parts and make necessary repairs before the next season.

