

# ST1028 Snow Thrower

## OPERATOR'S MANUAL

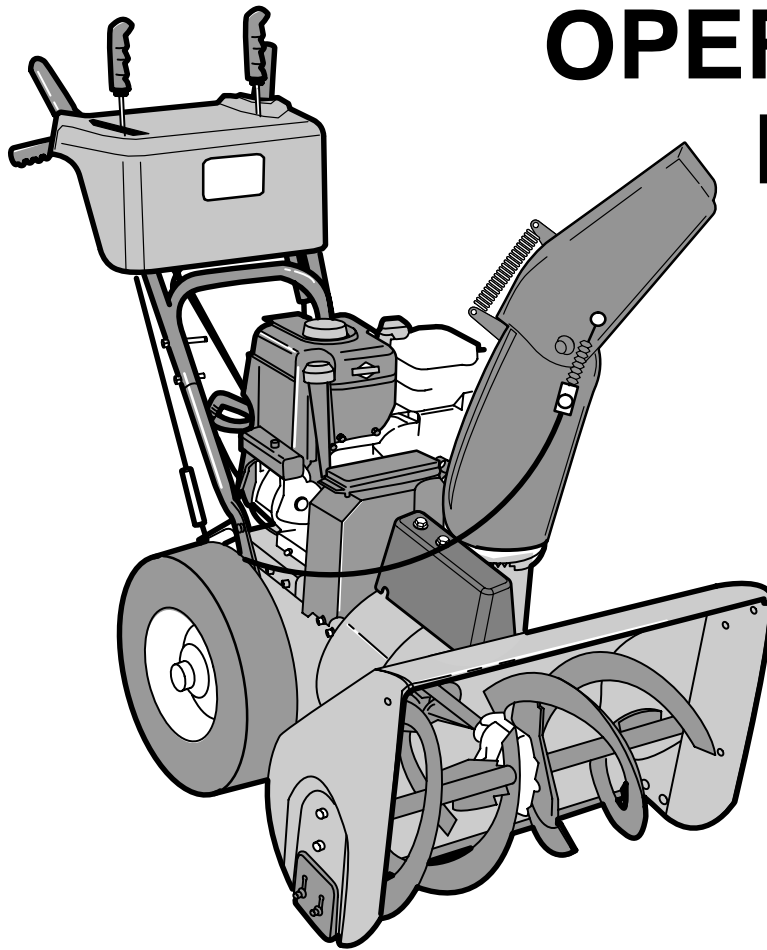

MTF-031042L

**FRONTIER**  
EQUIPMENT™

---

# INTRODUCTION

---

Congratulations on your purchase of a Frontier Snowthrower. It has been designed, engineered and manufactured to give you the best possible dependability and performance. However, like all mechanical products, your machine will occasionally require adjustment and maintenance. This handbook should be read before operating or performing and adjustments on your machine.

The instructions in this Owner's Manual are written for a person with some mechanical ability. Like most service books, not all the steps are described. Steps on how to loosen or tighten fasteners are steps anyone can follow with some mechanical ability. Read and follow these instructions before you use the unit.

**Know your product::** If you understand the unit and how the unit operates, you will get the best performance. As you read this manual, compare the illustrations to the unit. Learn the location and the function of the controls. To help prevent an accident, follow the operating instructions and the safety rules. Keep this manual for future reference.

**IMPORTANT:** Many units are not assembled and are sold in cartons. It is the responsibility of the owner to make sure the assembly instructions in this manual are exactly followed. Other units are purchased in an assembled condition. On assembled units, it is the responsibility of the owner to make sure the unit is correctly assembled. The owner must carefully check the unit according to the instructions in this manual before it is first used.

The warranty, found in this manual, details the coverage and limitations of this product. **Registration of the warranty is necessary and must be preformed by the dealer within sixty (60) days from the date of retail sale or delivery.** The Warranty Registration Form is located on the Frontier website.

## RESPONSIBILITY OF THE OWNER

**The responsibility of the owners to follow the instructions below.**

1. Carefully read and follow the rules for safe operation.
2. Follow all the assembly instructions.
3. Inspect the unit.
4. Make sure that the operator of the unit knows how to correctly use all standard and accessory equipment.
5. Operate the unit only with guards, shields, and other safety items in place and working correctly.
6. Correctly adjust the unit.
7. Service the unit only with authorized or approved replacement parts.
8. Complete all maintenance on the unit.

## PRODUCT INFORMATION

**The owner must be certain that all the product information is included with this unit.**

**This information includes the *INSTRUCTION BOOKS*, the *REPLACEMENT PARTS* and the *WARRANTIES*. This information must be included to make sure state laws and other laws are followed.**

**Read And Keep This Book For  
Future Reference. This Book Contains Important Information On:  
*SAFETY, ASSEMBLY, OPERATION AND MAINTENANCE.***

---

# RULES FOR SAFE OPERATION

---

## IMPORTANT



**WARNING:** Always disconnect the spark plug wire and place it where it cannot make contact with spark plug to prevent accidental starting during: Preparation, Maintenance, or Storage of your snowthrower.



### Safe Operation Practices for Snowthrowers As Recommended By: American National Standards Institute.



## WARNING:



**Engine Exhaust, some of its constituents, and certain vehicle components contain or emit chemicals known to the State of California to cause cancer and birth defects or other reproductive harm.**

**Battery posts, terminals and related accessories contain lead and lead compounds, chemicals known to the State of California to cause cancer and birth defects or other reproductive harm. WASH HANDS AFTER HANDLING.**

**IMPORTANT:** Safety standards require operator presence controls to minimize the risk of injury. Your snowthrower is equipped with such controls. Do not attempt to defeat the function of the operator presence control under any circumstances.

### Training

1. Read the operating and service instruction manual carefully. Be thoroughly familiar with the controls and the proper use of the equipment. Know how to stop the unit and disengage the controls quickly.
2. Never allow children to operate the equipment. Never allow adults to operate the equipment without proper instruction.
3. Keep the area of operation clear of all persons, particularly small children and pets.
4. Exercise caution to avoid slipping or falling especially when operating in reverse.

### Preparation

1. Thoroughly inspect the area where the equipment is to be used and remove all doormats, sleds, boards, wires, and other foreign objects.
2. Disengage all clutches before starting the engine (motor).
3. Do not operate the equipment without wearing adequate winter outer garments. Wear footwear that will improve footing on slippery surfaces.
4. Handle fuel with care; it is highly flammable.

MTF-031042L

- a. Use an approved fuel container.
  - b. Never remove fuel tank cap or add fuel to a running engine (motor) or hot engine (motor).
  - c. Fill fuel tank outdoors with extreme care. Never fill fuel tank indoors.
  - d. Replace fuel cap securely and wipe up spilled fuel.
  - e. Never store fuel or snowthrower with fuel in the tank inside of a building where fumes may reach an open flame or spark.
  - f. Check fuel supply before each use, allowing space for expansion as the heat of the engine (motor) and/or sun can cause fuel to expand.
5. For all units with electric starting motors use electric starting extension cords certified CSA/UL. Use only with a receptacle that has been installed in accordance with local inspection authorities.
  6. Adjust the snowthrower height to clear gravel or crushed rock surface.
  7. Never attempt to make any adjustments while the engine (motor) is running (except when specifically recommended by manufacturer).
  8. Let engine (motor) and snowthrower adjust to outdoor temperatures before starting to clear snow.
  9. Always wear safety glasses or eye shields during operation or while performing an adjustment or repair to protect eyes from foreign objects that may be thrown from the snowthrower.

### Operation

1. Do not operate this machine if you are taking drugs or other medication which can cause drowsiness or affect your ability to operate this machine.
2. Do not use this machine if you are mentally or physically unable to operate this machine safely.
3. Do not put hands or feet near or under rotating parts. Keep clear of the discharge opening at all times.
4. Exercise extreme caution when operating on or crossing gravel drives, walks or roads. Stay alert for hidden hazards or traffic.
5. After striking a foreign object, stop the engine (motor), remove the wire from the spark plug, thoroughly inspect snowthrower for any damage, and repair the damage before restarting and operating the snowthrower.
6. If the unit should start to vibrate abnormally, stop the engine (motor) and check immediately for the cause. Vibration is generally a warning of trouble.

# RULES FOR SAFE OPERATION

7. Stop the engine (motor) whenever you leave the operating position, before unclogging the auger/impeller housing or discharge chute and when making any repairs, adjustments, or inspections.
8. When cleaning, repairing, or inspecting, make certain the auger/impeller and all moving parts have stopped and all controls are disengaged. Disconnect the spark plug wire and keep the wire away from the spark plug to prevent accidental starting.
9. Take all possible precautions when leaving the snowthrower unattended. Disengage the auger/ impeller, stop engine (motor), and remove key.
10. Do not run the engine (motor) indoors, except when starting the engine (motor) and for transporting the snowthrower in or out of the building. Open the outside doors; exhaust fumes are dangerous (containing CARBON MONOXIDE, an ODORLESS and DEADLY GAS).
11. Do not clear snow across the face of slopes. Exercise extreme caution when changing direction on slopes. Do not attempt to clear steep slopes.
12. Never operate the snowthrower without proper guards, plates or other safety protective devices in place.
13. Never operate the snowthrower near enclosures, automobiles, window wells, drop-offs, and the like without proper adjustment of the snow discharge angle. Keep children and pets away.
14. Do not overload the machine capacity by attempting to clear snow at too fast a rate.
15. Never operate the machine at high transport speeds on slippery surfaces. Look behind and use care when backing up.
16. Never direct discharge at bystanders or allow anyone in front of the unit.
17. Disengage power to the collector/impeller when snowthrower is transported or not in use.
18. Use only attachments and accessories approved by the manufacturer of the snowthrower (such as tire chains, electric start kits, ect.).
19. Never operate the snowthrower without good visibility or light. Always be sure of your footing and keep a firm hold on the handles. Walk; never run.
20. Do not over- reach. Keep proper footing and balance at all times.
21. Exercise caution if operating on steep sloping surfaces.
22. This snowthrower is for use on sidewalks, driveways and other ground level surfaces.
23. Do not use the snowthrower on surfaces above ground level such as roofs of residences, garages, porches or other such structures or buildings.

## Maintenance And Storage

1. Check shear bolts and other bolts at frequent intervals for proper tightness to be sure the equipment is in safe working condition.
2. Never store the snowthrower with fuel in the tank inside a building where ignition sources are present such as hot water and space heaters, clothes dryers, and the like. Allow the engine (motor) to cool before storing in any enclosure.
3. Always refer to operator's guide instructions for important details if the snowthrower is to be stored for an extended period.
4. Maintain or replace safety and instruction labels, as necessary.
5. Run the snowthrower a few minutes after throwing snow to prevent freeze-up of the auger/impeller.



**WARNING: Avoid injury from rotating auger- keep hands, feet, and clothing away.**

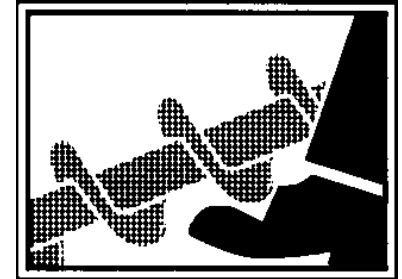

**WARNING: Do not use hands to unclog discharge chute.**

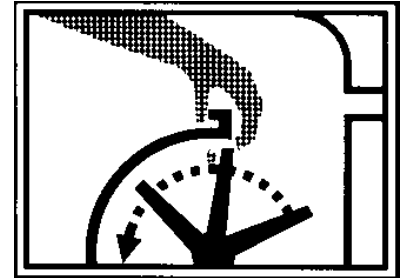

- Stop engine/motor before removing debris.
- Do not walk in front of running machine.
- Do not discharge at bystanders.
- Keep people and pets a safe distance from the machine.
- Before leaving machine, shut off engine/ motor and remove key.

---

# TABLE OF CONTENTS

---

<b>SAFETY DECALS</b> .....	<b>6</b>
<b>WARRANTY</b> .....	<b>7</b>
<b>OWNER'S INFORMATION</b> .....	<b>7</b>
<b>ASSEMBLY</b> .....	<b>8</b>
TOOLS REQUIRED FOR ASSEMBLY .....	8
CONTENTS OF SHIPPING CARTON .....	8
PARTS BAGS CONTENTS: .....	8
UNPACKING .....	9
UPPER HANDLE AND CRANK ASSEMBLY .....	10
CHECK THE CABLES .....	10
HOW TO SET THE LENGTH OF THE CABLES .....	10
REMOTE CHUTE CONTROL KNOB .....	11
SPEED SELECT KNOB .....	11
HOW TO INSTALL THE SPEED CONTROL ROD .....	11
SNOW CHUTE ASSEMBLY .....	12
IMPORTANT! BEFORE YOU START OPERATING .....	12
<b>OPERATION</b> .....	<b>13</b>
ENGINE AND SNOWTHROWER CONTROLS .....	13
SNOWTHROWER OPERATION .....	14
HOW TO REMOVE SNOW FROM THE AUGER .....	15
HOW TO USE THE WHEEL LOCKOUT .....	15
HOW TO SET THE DRIFT CUTTERS .....	15
BEFORE STARTING ENGINE .....	16
TO START ENGINE .....	17
OPERATING TIPS .....	18
<b>SERVICE RECOMMENDATIONS</b> .....	<b>19</b>
<b>MAINTENANCE</b> .....	<b>20</b>
LUBRICATION .....	20
ENGINE .....	22
AUGER HOUSING HEIGHT ADJUSTMENT .....	23
BELT ADJUSTMENT .....	24
HOW TO REPLACE THE BELTS .....	25
BELT GUIDE ADJUSTMENT .....	27
TRACTION DRIVE CABLE ADJUSTMENT .....	28
HOW TO ADJUST OR REPLACE THE FRICTION WHEEL .....	29
HOW TO REMOVE THE SNOW HOOD .....	32
AUGER SHEAR BOLT REPLACEMENT .....	33
TO ADJUST OR REPLACE THE SPARK PLUG .....	33
<b>STORAGE</b> .....	<b>34</b>
<b>TROUBLE SHOOTING CHART</b> .....	<b>35</b>
<b>REPLACEMENT PARTS</b> .....	<b>36</b>
<b>PARTS SCHEMATICS</b> .....	<b>37</b>
<b>SPECIFICATIONS</b> .....	<b>56</b>

# SAFETY DECALS

 **WARNING:** If safety decals are damaged or missing, replace immediately. 

 **Look for this symbol to indicate important safety precautions. This symbol indicates: “Attention! Become Alert! Your Safety Is At Risk.”**

Before operation of your snowthrower, read the safety decals as shown on your snowthrower. The cautions and warnings are for your safety. To avoid a personal injury or damage to your snowthrower, understand and follow all safety decals. If you have any questions regarding the meaning or how to comply with the instructions, do not operate until you understand the purpose for the warning or danger given in the safety decal. If you do not understand

the meaning, then thoroughly read all safety and operation instructions in this Owner’s Manual or contact your local dealer.

If any safety decals become worn or damaged and cannot be read, order replacement decals from your local dealer.

## Identifying Your Snowthrower

The snowthrower has two (2) identifying numbers: (1) unit model number: (2) unit serial number. The two preceding numbers are required to insure that the proper replacement parts are obtained when required. If you have any questions concerning parts, service, or technical data, contact the dealer where the unit was purchased. For complete warranty information refer to the warranty in the Owner’s Information section of this manual.

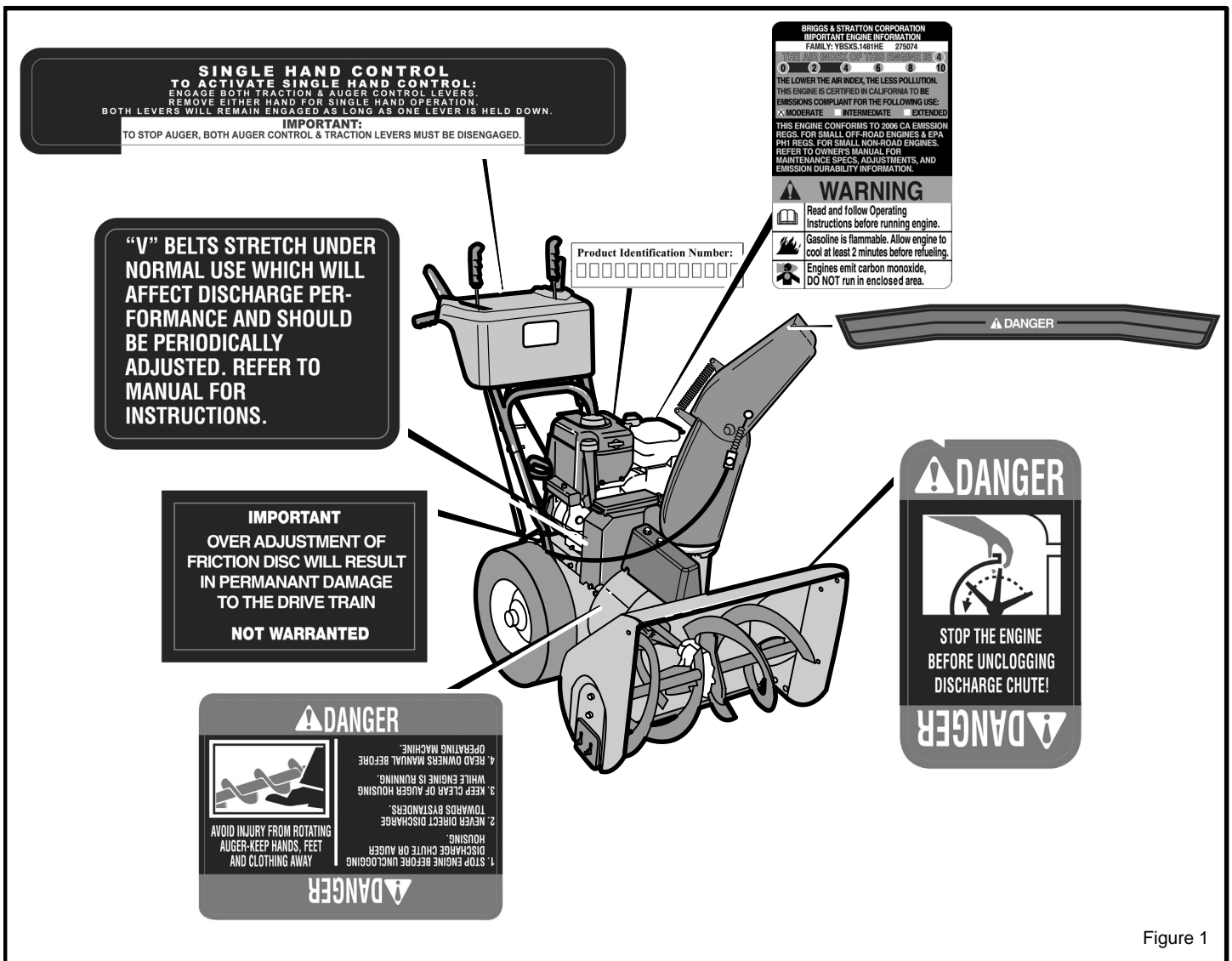

Figure 1

---

# OWNER'S INFORMATION

---

## THREE YEAR LIMITED WARRANTY

Murray warrants to the original purchaser of this Frontier Branded Snowthrower that this unit shall be free from defects in material and workmanship under normal use and service for a period of **Three (3) Year** from the date of purchase; however, this warranty does not cover accessories (such as electric starters) and Normal Wear Parts (except as noted below) as the companies that manufacture these items furnish their own warranties and provide service through their authorized field service facilities. For additional information, see the warranties covering these particular parts. If you are uncertain whether your unit contains or is equipped with one or more of these parts, consult your dealer prior to purchase. Subject to the terms and conditions noted in this Limited Warranty, we shall, at our option, repair or replace at no cost to the original purchaser any part covered by this Limited Warranty during the applicable warranty period.

Normal Wear Parts are defined as drive belts, augers, shear pins, tires and headlights. These parts are warranted to be free from defects in material and workmanship as delivered with the product. Any claim for repair or replacement of Normal Wear Parts must be made within thirty (30) days of the date of purchase. No claims involving damage caused from material use, abuse or misuse will be honored.

This Murray **Three (3) Year Limited Warranty** for your Frontier Branded Snowthrower is your exclusive remedy; however, this warranty is void or does not apply to any unit that has been tampered with, altered, misused, abused. If used for commercial and/or professional (non-homeowner) uses, the duration of this warranty is ninety (90) days after the date of purchase. Your warranty does not cover minor mechanical adjustments which are not due to any defect in material or workmanship. For assistance in making such adjustments, consult your Operator's Manual.

The engine on this Frontier Branded Snowthrower is warranted to the original purchaser for a **Three (3) Year Limited Warranty** by the equipment manufacturer. See your engine manual for information regarding the warranty policy and items covered under warranty. See your authorized John Deere/Frontier Dealer for service or replacement parts. **MB**

To make a claim under this Murray **Three (3) Year Limited Warranty** for your Frontier Branded Snowthrower, return the unit (or if authorized in advance, the defective part) along with your proof of purchase to an Authorized John Deere/Frontier Dealer near you. To locate the nearest Authorized John Deere/Frontier Dealer, check the Yellow Page listings in your local telephone directory. If you return the entire unit, John Deere/Frontier will repair all warranty items. If authorize to return the defective part only, John Deere/Frontier will either replace or repair the part. This Murray **Three (3) Year Limited Warranty** for your Frontier Branded Snowthrower gives you specific legal rights, and you may also have other rights which vary from state to state. **This Limited Warranty is given in lieu of all other expressed and implied warranties including the implied warranty of merchantability and warranty of fitness for a particular purpose.** If you need additional information on this written warranty or assistance in obtaining service, contact you local John Deere/Frontier Dealer.

## FOR YOUR RECORDS

DATE PURCHASED: \_\_\_\_\_

MODEL NO: \_\_\_\_\_

SERIAL NO: \_\_\_\_\_

STORE WHERE PURCHASED: \_\_\_\_\_

ADDRESS: \_\_\_\_\_

CITY: \_\_\_\_\_ STATE: \_\_\_\_\_

TELEPHONE : \_\_\_\_\_

Record this information about your unit so that you will be able to provide it in case of loss or theft.

# ASSEMBLY

## TOOLS REQUIRED FOR ASSEMBLY

- 1 - Knife
- 2 - 1/2" wrenches (or adjustable wrenches)
- 2 - 9/16" wrenches (or adjustable wrenches)
- 2 - 3/4" wrenches (or adjustable wrenches)
- 1 - 3/8" wrenches (or adjustable wrenches)
- 1 - Pair pliers or screw driver (to spread cotter pin)

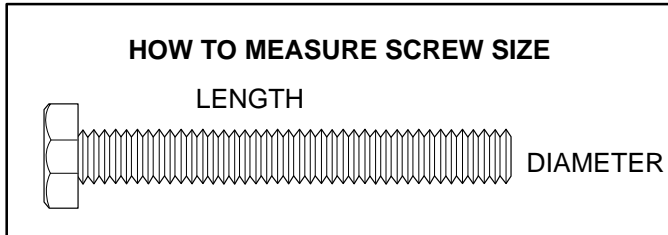

## CONTENTS OF SHIPPING CARTON

- 1- Snowthrower
- 1- Container of Fuel Stabilizer (Located in Parts Bag)
- 1- Crank Assembly
- 1- Parts Bag



**WARNING: Always wear safety glasses or eye shields while assembling snowthrower.**

## PARTS BAGS CONTENTS:

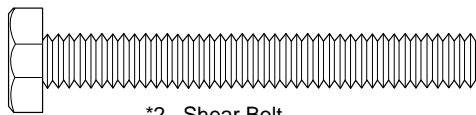

\*2- Shear Bolt

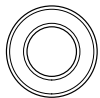

\* 2-Spacer

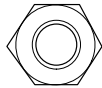

\*2- Nut



1 - Shift Lever Knob  
(not actual size)



1 - Remote Chute Knob  
(not actual size)



1 - Washer

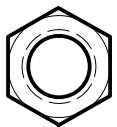

1 - Nut

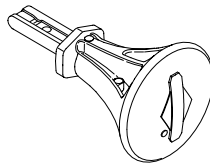

1 - Ignition Keys

\* Non Assembly parts are found in toolbox located on top of belt cover.



# ASSEMBLY

Figure 2 shows the snowthrower in the shipping position.

Figure 3 shows the snowthrower completely assembled.

Reference to right and left hand side of the snowthrower is from the operator's position at the handle.

## UNPACKING

1. Locate the two tear tabs at the bottom of the carton.
2. Pull the tear tape no more than twelve inches (30.48cm.) at a time. Re-grasp tape next to the carton and pull again. Repeat until all the tape is torn off.
3. After the tape has been completely removed from the carton, remove the carton from the base. Cut all four corners and fold the sides toward the center for easy disposal.
4. Remove the plastic bag that covers the unit.
5. Locate and remove the parts bag.

**NOTE: Set the fuel stabilizer aside until adding gasoline to the fuel tank. We recommend that fuel stabilizer is added to the fuel each time that gasoline is added to the fuel tank.**

6. For shipping purposes, the **height adjust skids** are attached to the pallet. Remove the **screw** that secures each **height adjust skid** to the pallet. (See Figure 2).
7. Roll the snowthrower off the carton by pulling on the lower handle.

**CAUTION: DO NOT back over cables.**

8. Remove the packing material from the handle assembly.
9. Cut ties securing the clutch control cables to the lower handle.

**NOTE: If the cables have become disconnected from the clutch levers, reinstall the cables as shown in Figure 4.**

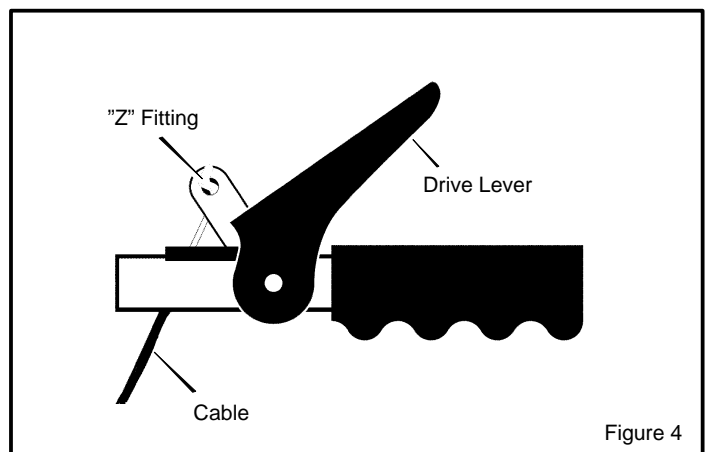
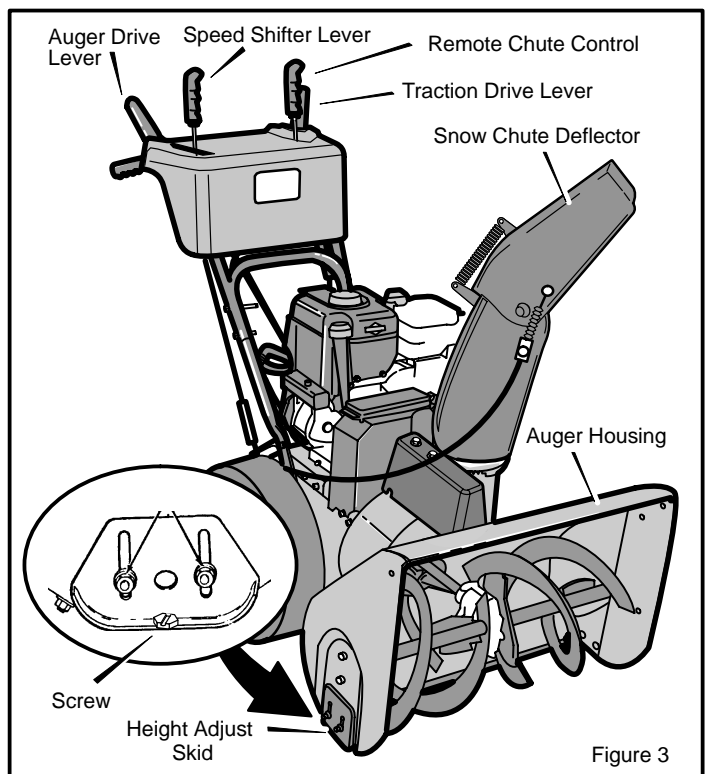
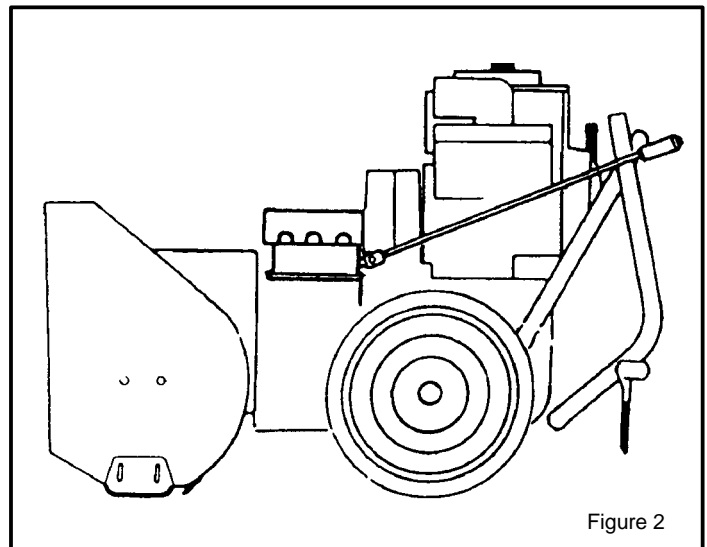

# ASSEMBLY

## UPPER HANDLE AND CRANK ASSEMBLY

1. Loosen, but do not remove the screws, flatwashers, lockwashers and hex nuts in the upper holes of the lower handle.
2. Remove the fasteners and the crank assembly eyebolt from the lower holes of the lower handle.
3. Raise upper handle into operating position. Upper handle should be to the outside of the lower handle.

**NOTE: Make sure the cables are not caught between the upper and lower handle.**

4. Install the fasteners and the crank assembly eyebolt that were removed in step 2. DO NOT tighten until all fasteners are in place.
5. Attach the crank rod to the universal joint assembly with the hair pin (see Figure 6).
6. Tighten nut on eye bolt. Make sure eye bolt is properly aligned and the crank can freely rotate.
7. Tighten all handle bolts.

**NOTE: Make sure crank does not touch carburetor cover.**

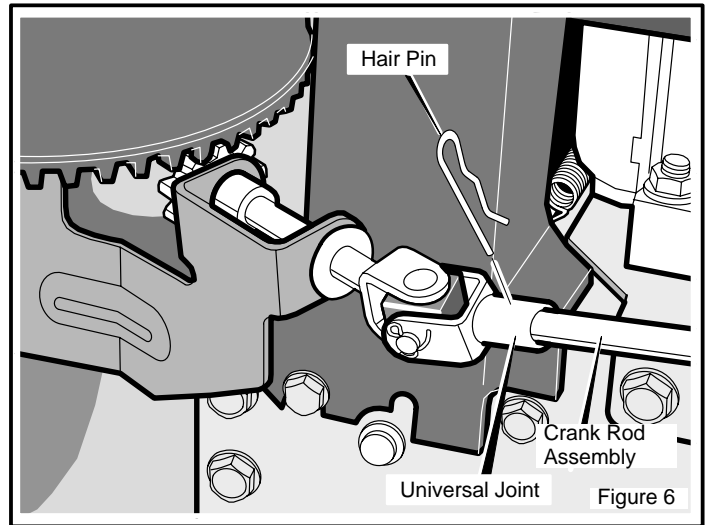
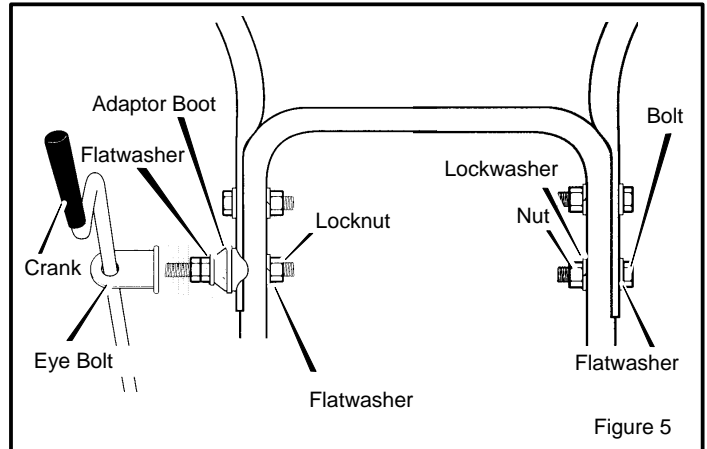

## CHECK THE CABLES

1. If control cables have become unattached from motor mount frame, reconnect cables as shown in Figure 7.
2. For cable adjustments, see "How To Check And Adjust The Cables" in the MAINTENANCE section.

## HOW TO SET THE LENGTH OF THE CABLES

The cables were adjusted at the factory and no adjustments should be necessary. However, after the handles are put in the operating position, the cables can be too tight or too loose. If an adjustment is necessary, see "How To Check And Adjust The Cables" in the MAINTENANCE section.

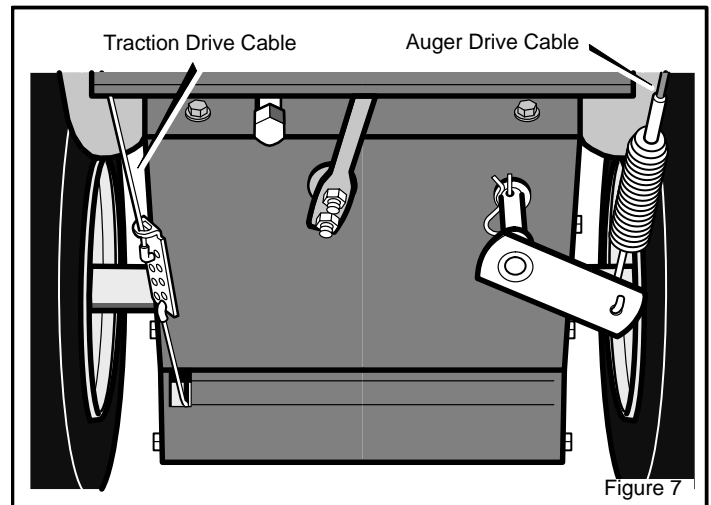

# ASSEMBLY

## REMOTE CHUTE CONTROL KNOB

1. Thread the knob onto the lever as far as possible.- Make sure that the knob points forward (See Figure 8).
2. Tighten the jam nut against the knob securely.

## SPEED SELECT KNOB

1. Thread the knob onto the lever as far as possible. Make sure that the knob points forward (See Figure 8).
2. Tighten the jam nut against the knob securely.

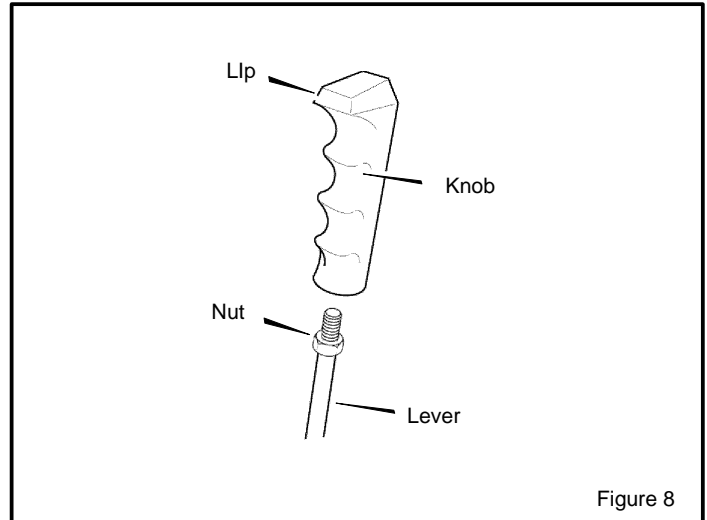

## HOW TO INSTALL THE SPEED CONTROL ROD

1. Put the **speed select lever** to the NEUTRAL position. See Figure 9.
2. Attach the **ball joint**, located on the bottom end of the **speed control rod**, to the **shift yoke assembly**. See Figure 10. The **fasteners** are attached to the **ball joint** at the factory.
3. The length of the **ball joint** and **speed control rod** have been pre-adjusted at the factory. If an adjustment is required, loosen the **nut**. Remove the **fasteners** to disconnect the **ball joint** from the **shift yoke assembly**. To lengthen or shorten the **speed control rod**, turn the **adapter** to obtain the correct length.
4. Make sure the **speed select lever** functions correctly. Move the **speed select lever** through all speeds.

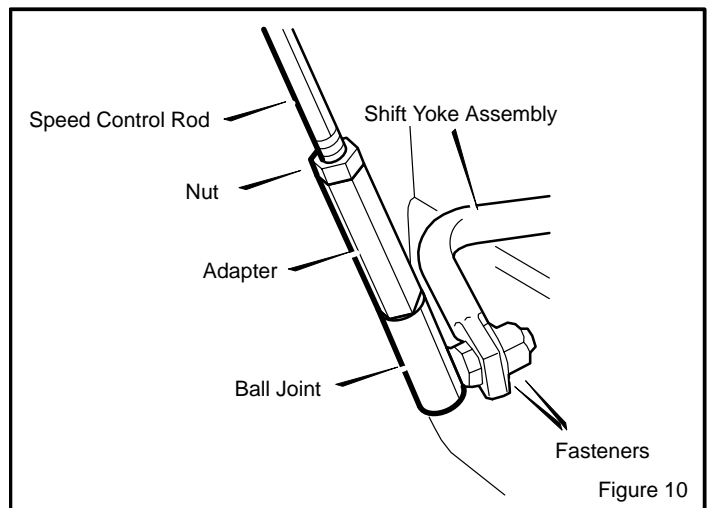
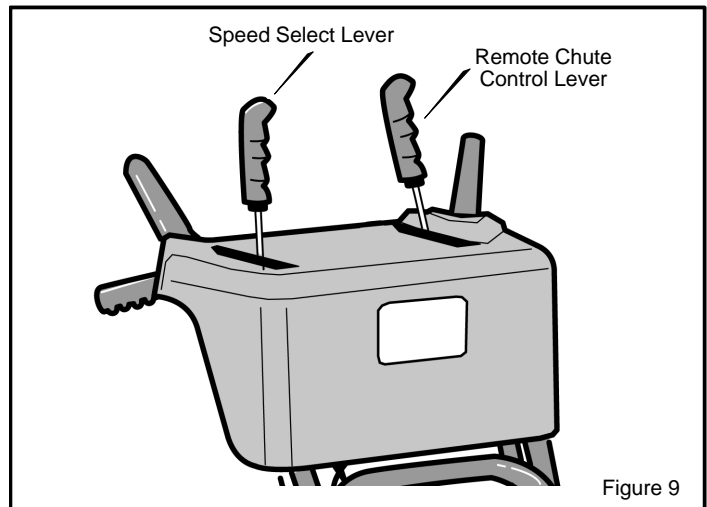

# ASSEMBLY

## SNOW CHUTE ASSEMBLY

1. Remove back carriage bolt (See Figure 11).
2. Tilt chute back into operating position (See Figure 12).
3. Replace carriage bolt from inside of chute.
4. Replace flatwasher and nylon locknut on outside of flange.
5. Tighten carriage bolt securely.

**NOTE: check all carriage bolts in flange for tightness. DO NOT overtighten.**

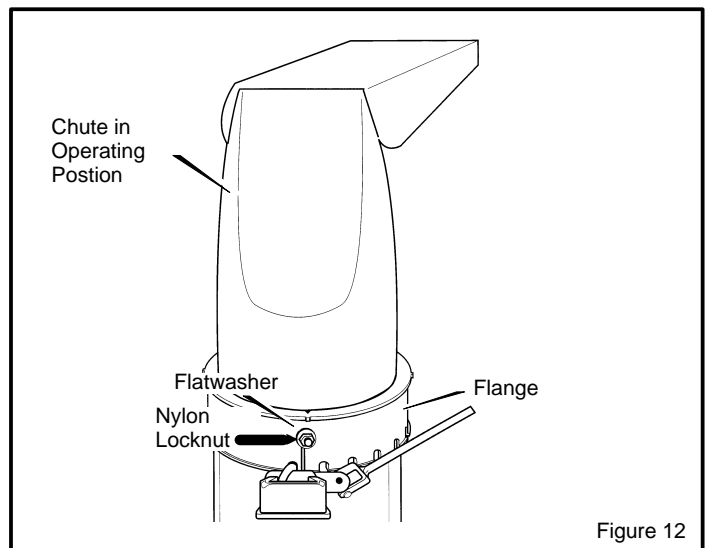
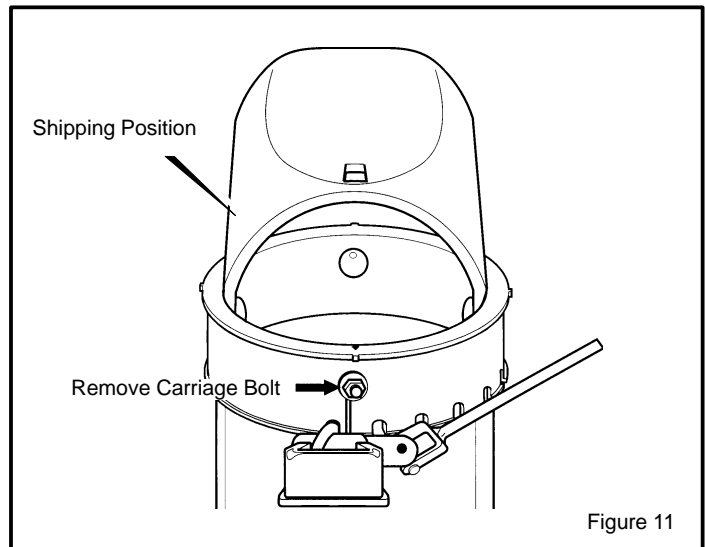

## CHECK THE TIRES

The tires were over inflated for shipment. Check the tire pressure in the tires. See the sidewall of the tire for the proper inflation.

## IMPORTANT! BEFORE YOU START OPERATING

- Check the fasteners. Make sure all fasteners are tight.
- On electric start models, the unit was shipped with the starter cord plugged into the engine. Before operating, unplug the starter cord from the engine.

**NOTE: This snow blower was shipped WITH OIL in the engine. See "Before Starting Engine" instructions in the Operation section of this manual before starting engine.**

# OPERATION

READ THIS OWNER'S MANUAL AND SAFETY RULES BEFORE OPERATING YOUR SNOWTHROWER. Compare the illustrations with your SNOWTHROWER to familiarize yourself with the location of various controls and adjustments. Save this manual for future reference.

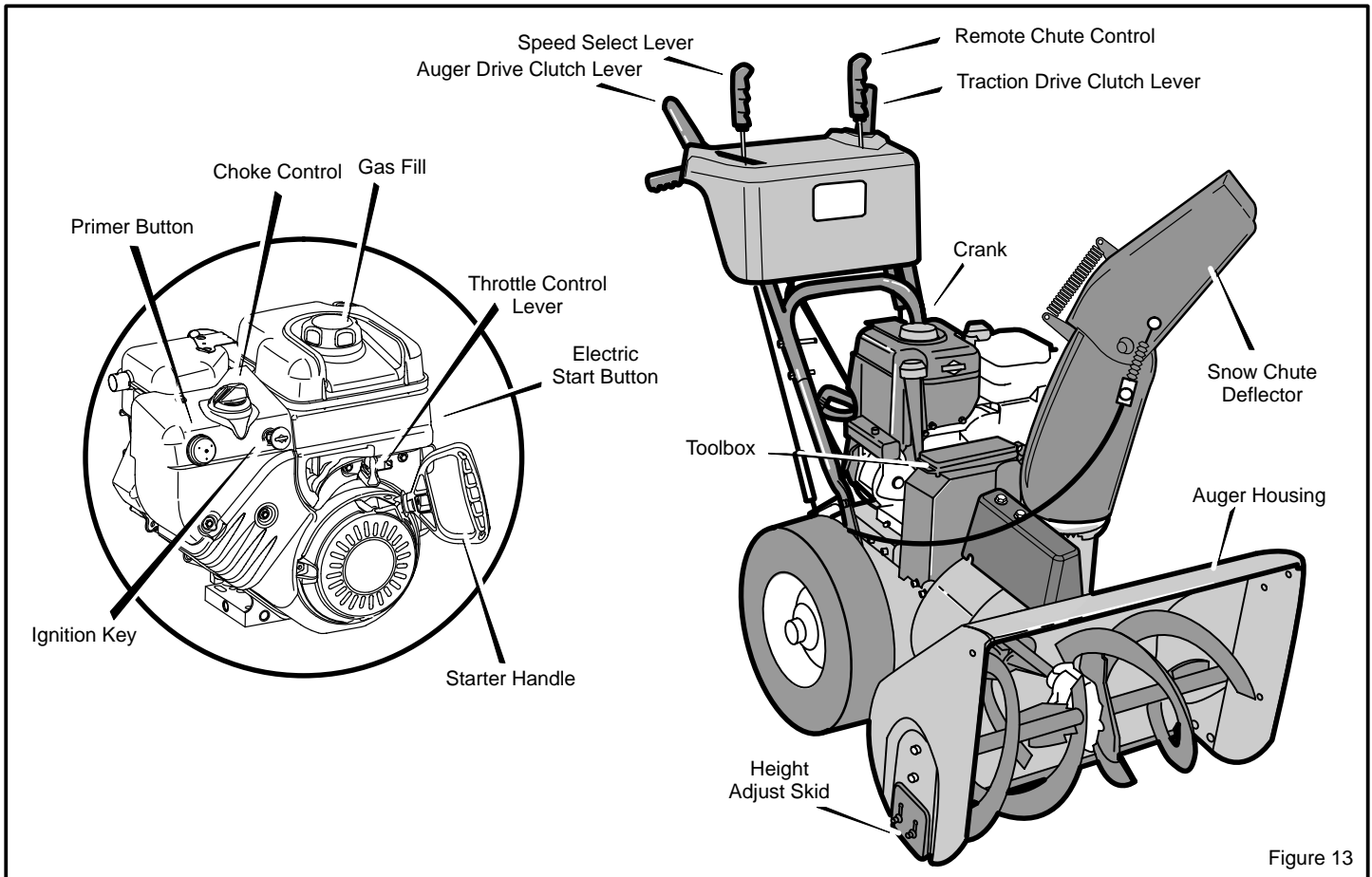

## ENGINE AND SNOWTHROWER CONTROLS

### ENGINE CONTROLS

**Throttle Control Lever** - Controls the engine speed.

**Choke Control**- Use to start a cold engine.

**Electric Start Button**- Used to start the engine using the 120 volt electric starter.

**Prime Button**- Used to inject fuel directly into carburetor manifold to insure fast starts in cool weather.

**Ignition Key**- Must be inserted to start engine. Pull out to stop. Do not turn ignition key.

**Starter Handle**- Starts the engine manually.

### SNOWTHROWER CONTROLS

**Speed Select Lever**- Allows the operator to use one of six (6) forward and two (2) reverse speeds. To shift, move speed select lever to desired position.

**NOTE: Do not move speed select lever while Traction Drive Clutch is engaged. This may result in severe damage to drive system.**

**Auger Drive Clutch Lever**- Used to engage and disengage the auger and impeller. To engage push down, to disengage release.

**Traction Drive Clutch Lever**- Used to propel snow blower forward or reverse. Push down to engage, release to disengage.

**Snow Chute Deflector**- Changes the direction the snow is blown.

**Remote Chute Control**- Push forward to discharge snow down. Pull back to discharge snow high and far.

**Crank**- Used to change direction of the snow discharge. Turn handle clockwise to turn chute to right. Turn handle counter clockwise to turn chute to left.

**Height Adjust Skid**- Used to adjust ground clearance of auger housing.

**Toolbox** - Spare shear pins, shear bolt wrenches and spacers are located in toolbox.

# OPERATION



The operation of any snowthrower can result in foreign objects being thrown into the eyes, which can result in severe eye damage. Always wear safety glasses or eye shields before beginning snowthrower operation. We recommend standard safety glasses or Wide Vision Safety Mask for over spectacles.

## SNOWTHROWER OPERATION

The most effective use of the snowthrower will be established by experience, taking into consideration the terrain, wind conditions and building location which will determine the direction of the discharge chute.

**NOTE: Do not blow snow toward a building as hidden objects could be blown with sufficient force to cause damage.**

## TO STOP YOUR SNOWTHROWER

1. To stop throwing snow, release the **auger drive lever**. (see Figure 14).
2. To stop the wheels, release the **traction drive lever**.
3. To stop the engine, push the **throttle control lever** to off and pull out the **ignition key**.

## TO CONTROL SNOW DISCHARGE

1. Rotate the **crank** to set the direction (left to right) of the discharge chute (see Figure 13).
2. Push the **remote chute lever** forward to discharge the snow down. Pull the **remote chute lever** back to discharge the snow high and far (see Figure 14).

## HOW TO MOVE FORWARD AND BACKWARD

1. Start the engine. See "To Start Engine" in the Operation section.

**NOTE: Always release the traction drive lever before moving the speed select lever.**

2. Ground speed is determined by snow conditions. Set the **speed select lever** in one of the following positions.

- |     |                                |
|-----|--------------------------------|
| 1-2 | Wet, Heavy, Slushy, Extra Deep |
| 3   | Moderate                       |
| 4-5 | Very Light                     |
| 6   | Transport Only                 |

**IMPORTANT: Before operating, make sure the area in front of snowthrower is clear of bystanders or obstacles.**

3. Engage the **traction drive lever** (see Figure 14). As the snowthrower starts to move, maintain a firm hold on the handles and guide the snowthrower along the cutting path. Do not attempt to push the snowthrower.
4. To stop forward motion, release the **traction drive lever**.
5. To move the snowthrower backwards, move the **speed select lever** into either first or second reverse position and engage the **traction drive lever**.

## TO THROW SNOW

1. Push down the **auger driver lever** (right hand). See Figure 14.
2. To stop throwing snow, release the **auger drive lever**.

**NOTE: When clearing wet, heavy snow, it is recommended that the ground speed of the unit be reduced, maintain full throttle and do not attempt to clear the full width of the unit.**

For additional operating instructions see "Operating Tips" in the Operation section.



**WARNING: Read Owner's Manual before operating machine. This machine can be dangerous if used carelessly.**

Never operate the snowthrower without all guards, covers, and shields in place.

Never direct discharge towards windows or allow bystanders near machine while engine is running.

Stop the engine whenever leaving the operating position.

Disconnect spark plug before unclogging the impeller housing or the discharge chute and before making repairs or adjustments.

When leaving the machine, remove the ignition key. To reduce the risk of fire, keep the machine clean and free from spilled gas, oil and debris.

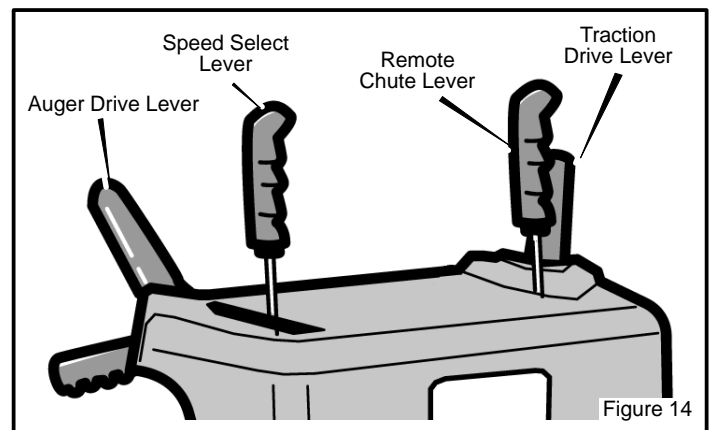

**WARNING: Never run engine indoors or in an enclosed, poor ventilated area. Engine exhaust contains CARBON MONOXIDE, an ORDERLESS and DEADLY GAS.**

Keep hands, feet, hair and loose clothing away from any moving parts on engine and snowthrower.

Temperature of muffler and nearby areas can exceed 150° F (66° C). Avoid these areas.

**DO NOT allow children or young teenagers to operate or be near snowthrower while it is operating.**

---

# OPERATION

---

## HOW TO REMOVE SNOW FROM AUGER



**WARNING:** Do not attempt to remove snow or debris that may become lodged in auger without taking the following precautions:

A cleaning stick is attached to the top of the auger housing. Use the cleaning stick to remove snow from the auger housing.

- Release auger drive lever.
- Move throttle lever to stop position.
- Remove (do not turn) ignition key.
- Disconnect spark plug wire.
- Do not place your hands in the auger or discharge chute. Use the cleaning stick to remove snow.

---

## HOW TO USE THE WHEEL LOCKOUT

Each wheel is secured to the axle with a lockout pin. See Figure 15. The unit was shipped with the lockout pin in the locked position. For ease of maneuverability, disconnect the lockout pin as follows.

1. Pull the **knob** out to disengage the lockout pin.
2. To lock in the disengaged position, turn the **knob** 1/4 turn (90 degrees).

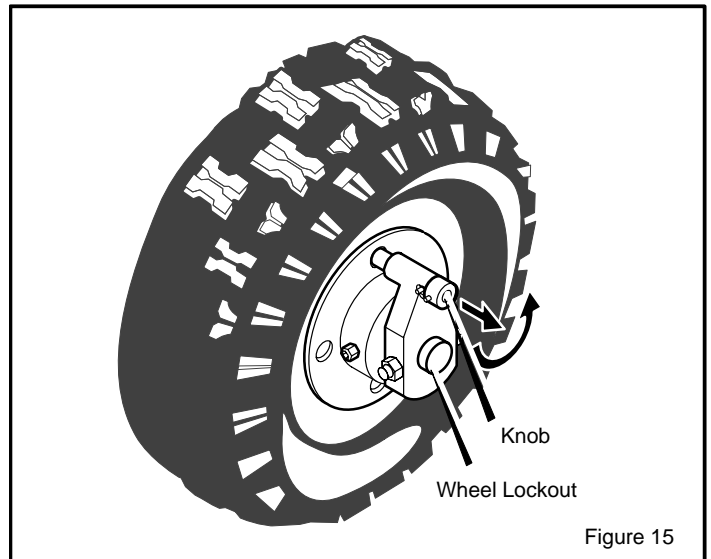

---

## HOW TO SET THE DRIFT CUTTERS

### (OPTIONAL ACCESSORY ON SOME MODELS)

Drift cutters are used to cut a path through snow deeper than the auger housing.

1. Loosen the **wingnuts** that secure the **drift cutters** to the auger housing (see Figure 16).
2. Raise the **drift cutters** to the desired height.
3. Tighten the **wingnuts**.

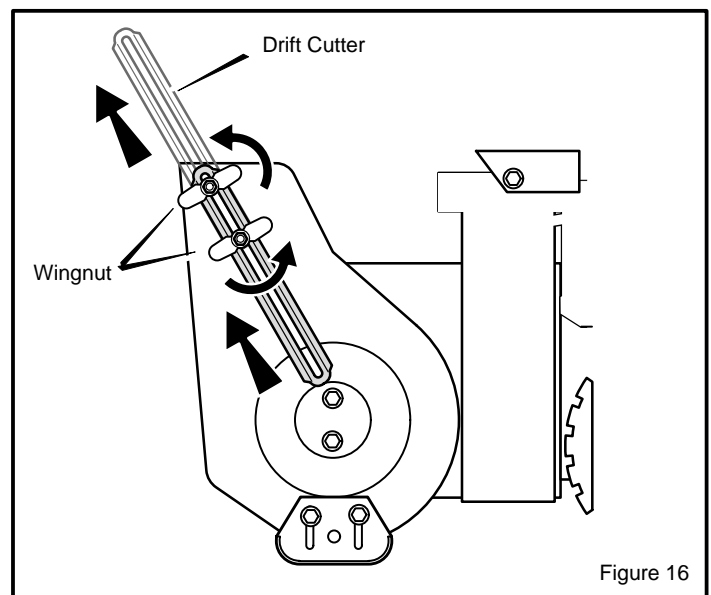

# OPERATION

## BEFORE STARTING ENGINE

### Check the oil

**NOTE:** The engine was shipped from the factory filled with oil. Check the level of the oil. Add oil as needed.

1. Make sure the unit is level.
2. Remove the oil fill cap/dipstick. Check the oil.

**NOTE:** Do not check the level of the oil while the engine runs.

3. If necessary, add oil until the oil reaches the FULL mark on the oil fill/cap dipstick (see Figure 17). Do not add too much oil.

**NOTE:** For extreme cold operating conditions of 0°F (-18°C) and below, use a synthetic 0W30 motor oil for easier starting.

**NOTE:** S.A.E. 5W30 motor oil may be used to make starting easier in areas where the temperature is 20°F (-7°C) to 0°F (-18°C).

**NOTE:** SEE CHART FOR OIL RECOMMENDATION

TEMPERATURE	TYPE OF OIL
0°F (-18°C) and above	S.A.E. 5W30
0°F (-18°C) and below	synthetic 0W30

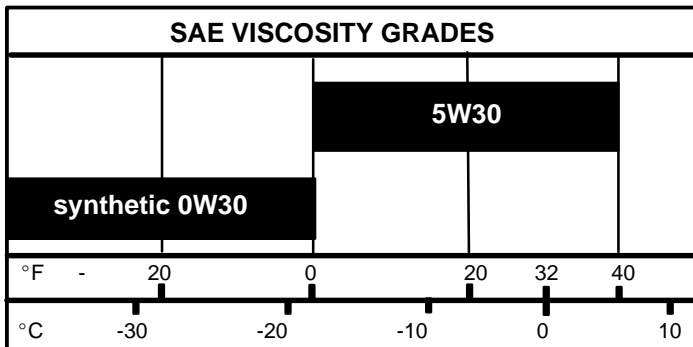

## FILL GAS

1. Fill the fuel tank with fresh, clean, unleaded regular, unleaded premium, or reformulated automotive gasoline along with a fuel stabilizer (follow instructions on fuel stabilizer package). **DO NOT** use leaded gasoline. We recommend that fuel stabilizer be added to the fuel each time that gasoline is added to the fuel tank.

**NOTE:** Winter grade gasoline has higher volatility to improve starting. Be certain container is clean and free from rust or other foreign particles. Never use gasoline that may be stale from long periods of storage in the container.

**CAUTION:** DO NOT use gasoline containing any amount of alcohol as it can cause serious damage to the engine or significantly reduce the performance.

2. Check to make sure that spark plug is tightened securely into engine and spark plug wire is attached to spark plug. If torque wrench is available, torque plug to 18-23 ft-lbs.



**WARNING:** Gasoline is flammable. Always use caution when handling or storing gasoline. Do not add gasoline to the fuel tank while snowthrower is running, hot, or when snowthrower is in an enclosed area. Keep away from open flame, electrical sparks and **DO NOT SMOKE** while filling the fuel tank. Never fill the fuel tank completely; but fill the fuel tank to within 1/4-1/2 inch (6.5-12.5 mm) from the top to provide space for the expansion of the fuel. Always fill fuel tank outdoors and use a funnel or spout to prevent spilling. Make sure to wipe up any spilled fuel before starting the engine.

Store gasoline in a clean, approved container, and keep the cap in place on the container. Keep gasoline in a cool well ventilated place; never in the house. Never buy more than a 30 day supply of gasoline to assure volatility. Gasoline is intended to be used as a fuel for internal combustion engines; therefore, do not use gasoline for any other purpose. Since many children like the smell of gasoline, keep it out of their reach because the fumes are dangerous to inhale, as well as being explosive.

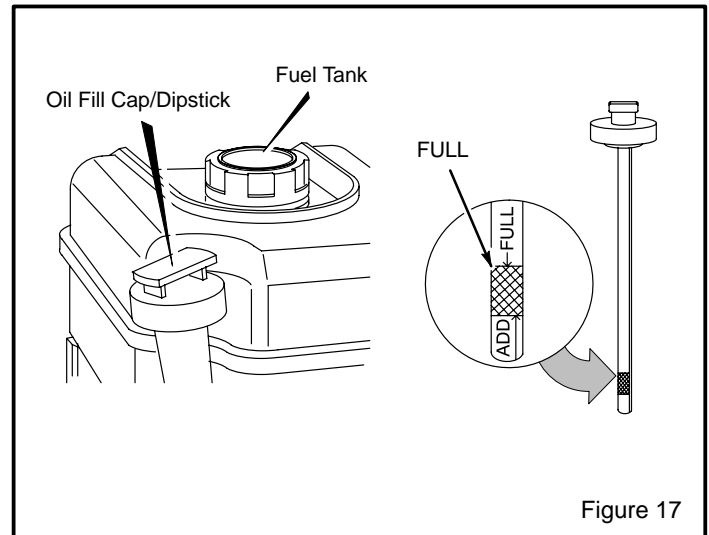

Figure 17

## BEFORE STOPPING THE ENGINE

Run the engine for a few minutes to help dry off any moisture on the engine.

To help avoid possible freeze-up of the starter, proceed as follows:

### Recoil Starter

With the engine running, pull the starter rope with a rapid continuous full arm stroke three or four times.

**NOTE:** The normal sound made by pulling the starter rope will not harm the engine or the starter.

### Electric Starter

1. Connect the power cord to the switchbox and then to a wall outlet.



# OPERATION

2. With the engine running, push the starter button and spin the starter for several seconds.

**NOTE: The normal sound made by spinning the starter will not harm the engine or the starter.**

3. Disconnect the power cord from the receptacle first and then from the switchbox.

## TO START ENGINE

Be sure that engine has sufficient oil.

The snowthrower engine is equipped with a recoil starter and also an electric starter.



**WARNING: The electric starter is equipped with a three-wire power cord and plug designed to operate on 120 volt AC house hold current. The power cord must be properly grounded at all times to avoid the possibility of electric shock which can cause injury to the operator. Follow all instructions carefully as set forth below:**

**Make sure your house has a three-wire grounded system. If you are not sure, ask a licensed electrician. If your house does not have a three-wire grounded system, do not use this electric starter under any condition.**

**If your house has a three-wire grounded system but a three hole receptacle is not available to connect the electric starter, have a three-hole receptacle installed by a licensed electrician.**



**WARNING: To connect a 120 volt power cord, always connect the power cord first to the switch box located on the engine and then plug the other end into a three-hole grounded receptacle.**



**WARNING: To disconnect the power cord, always unplug the end connected to the three-hole grounded receptacle first.**

## COLD ENGINE START

(Engine has not been run recently.)

1. Be sure auger drive clutch lever and traction drive clutch lever are in the disengaged (RELEASED) position.
2. IN TEMPERATURES ABOVE 0°F (-18°C)  
Move throttle control to "FAST" position.  
IN TEMPERATURES BELOW 0°F (-18°C)  
Move throttle control to "1/2 THROTTLE" position. Before engaging auger drive clutch lever allow engine to idle for five minutes to allow engine oil to warm . Failure to allow engine oil to warm can cause damage to engine.
3. Insert key into ignition slot. Make sure it snaps into place (Figure 18). Do not turn key.
4. Rotate choke knob to the CHOKE position.

MTF-031042L

5. Push the primer button as follows:  
Above 50° F (10° C), DO NOT PRIME.  
From 50° F (10° C) to 15°F (-10° C), PUSH TWO TIMES.  
Below 15° F (-10° C), PUSH FOUR TIMES.

**NOTE: Cover the vent hole when as you push the primer. Remove your finger from the primer vent hole between pushes.**

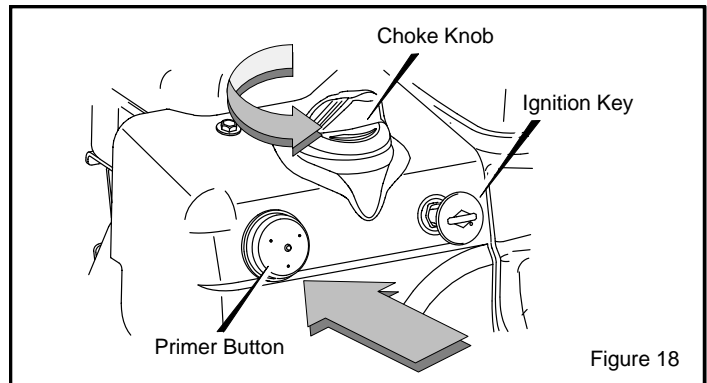

Figure 18

6. (**RECOIL START**) Pull starter handle (Figure 19) rapidly, and allow to rewind slowly while maintaining firm grip on handle.

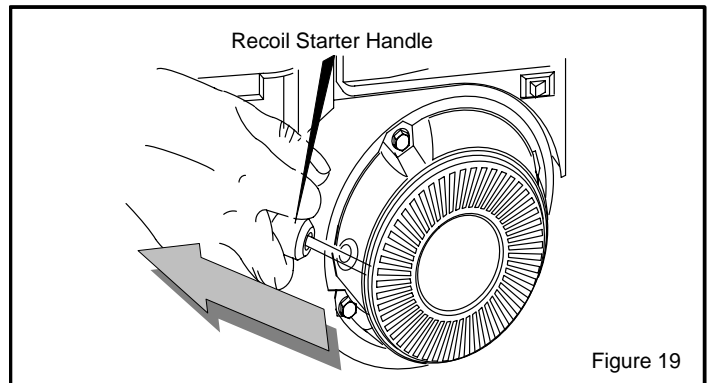

Figure 19

7. (**ELECTRIC START**) Connect the power cord to the engine and depress the starter button.

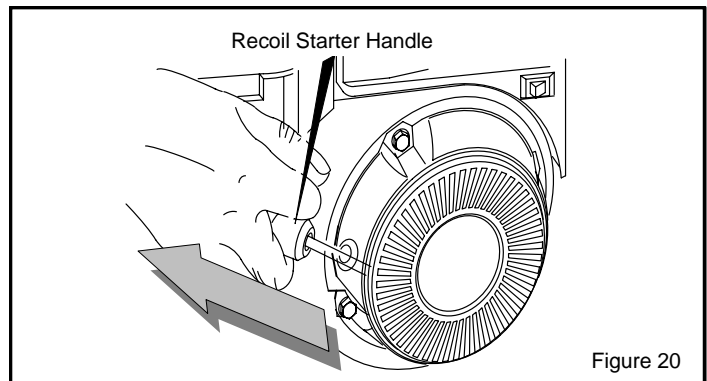

Figure 20

8. As engine warms up move choke lever to "1/2 choke" position. When engine does not run smoothly, move choke lever to the off position.

**NOTE: Allow the engine to warm up for several minutes before blowing snow in temperatures below 0°F (-18° C).**

9. Run engine at or near top speed.

---

# OPERATION

---

10. To stop engine, move throttle control lever to STOP position. Remove key. Do not turn key.

## WARM ENGINE START (RECOIL STARTER)

If restarting a warm engine after a short shutdown, leave choke at "OFF" and do not push the primer button. If the engine fails to start, follow the Cold Start instructions.

## FROZEN STARTER

If the starter is frozen and will not turn engine:

1. Pull as much rope out of the starter as possible.
2. Release the starter handle and let it snap back against the starter. Repeat until the engine starts.

To help prevent possible freeze-up of recoil starter and engine controls, proceed as follows after each snow removal job.

### Recoil Starter:

1. With engine running, pull starter rope hard with a continuous full arm stroke three or four times.

**NOTE: The unusual sound made by pulling the starter rope will not harm the engine or the starter.**

### Electric Starter:

1. Connect the "POWER CORD" to the "SWITCH BOX" and then to a 120 volt AC receptacle.

2. With engine running, push the "STARTER BUTTON" and spin the starter for several seconds.

**NOTE: The unusual sound made by spinning the starter will not harm the engine or the starter.**

3. Disconnect the "POWER CORD" from the receptacle first and then from the "SWITCH BOX".

With engine not running, wipe all snow and moisture from carburetor cover in area of control levers. Also move control levers backward and forward several times.

**IMPORTANT: After each use of the snowthrower, stop the engine, remove the ignition key, remove all accumulated snow from the snowthrower and wipe clean. Store the snowthrower in a protected area.**

**NOTE: Never cover snowthrower while engine and exhaust area are still warm.**

If after following the preceding instructions, your engine fails to start, have the engine checked by a John Deere/Frontier dealer.

**NOTE: Do not lose the ignition key. Key the ignition key is a safe place. The engine will not start without the ignition key.**

---

## OPERATING TIPS

1. For optimum snowthrower efficiency, adjust ground speed, not the throttle. REMEMBER - if the wheels slip, forward speed will be reduced. The engine is designed to deliver optimum performance at full throttle and must be run at this power setting at all times.
2. Most efficient snowblowing is accomplished when snow is removed immediately after it falls.
3. For complete snow removal, slightly overlap each swath previously taken.
4. Snow should be discharged downwind whenever possible.
5. For normal usage, set the skids one-eighth inch (3 mm) below the scraper bar. For extremely hard-packed snow surfaces, the skids may be adjusted upward to insure cleaning efficiency.

6. On gravel or crushed rock surfaces, the skids should be set at 1-1/4 inch (32 mm) below the scraper bar (see To Adjust Skid Height, in the MAINTENANCE section in this manual). Rocks and gravel must not be picked up and thrown by the machine.
7. After the snowblowing job has been completed, allow the engine to idle for a few minutes, to melt snow and ice accumulated on the engine.
8. Remove ice and snow accumulation from the entire snowthrower to prevent obstructions and possible damage when snowthrower is subsequently operated.
9. Before starting snowthrower, always inspect augers and impeller for ice accumulation and/or debris, which could result in snowthrower damage.
10. Check oil level before every start. fill to "SAFE" indication prior to operating snowthrower.

# SERVICE RECOMMENDATIONS

SERVICE RECOMMENDATIONS									
PROCEDURE		FIRST 2 HOUR	BEFORE EACH USE	OFTEN	EVERY 5 HOURS	EVERY 10 HOURS	EVERY 25 HOURS	BEGINNING EACH SEASON	BEFORE STORAGE
<b>S N O W T H R O W E R</b>	Tighten all screws and nuts	√		√				√	
	Check Traction Clutch Cable Adjustment (See Cable Adjustment)	√						√	
	Check Auger Clutch Cable Adjustment (See Cable Adjustment)	√						√	
	Adjust Drive Belts	√					√	√	
	Lubricate Chains and Hex Shaft							√	√
	Lubricate Auger Shaft (See Shear Bolt Replacement)					√			√
<b>E N G I N E</b>	Oil, Check		√		√			√	
	Oil, Change	√					√	√	

The warranty on this snowthrower does not cover items that have been subjected to operator abuse or negligence. To receive full value from the warranty, operator must maintain snowthrower as instructed in this manual. The following **Service Recommendations** is supplied to assist operator to properly maintain snowthrower. This is a check list only. Adjustment referred to will be found in the MAINTENANCE section of this manual.

## AFTER EACH USE

1. Check for any loose or damaged parts.
2. Tighten any loose fasteners.
3. Check and maintain the auger.
4. After each use, remove all snow and slush off the snowthrower to prevent freezing of auger or controls.
5. Check controls to make sure they are functioning properly.
6. If any parts are worn or damaged, replace immediately.

---

# MAINTENANCE

---

Some adjustments will need to be made periodically to properly maintain your snowthrower.

All adjustments in the MAINTENANCE section of this manual should be checked at least once each season.

## SNOWTHROWER

The following adjustment should be performed more than once each season.

**Auger and Traction Drive Belts** should be adjusted after the first 2 to 4 hours of use, again about mid-season and twice each season thereafter (See To Adjust Belts paragraph in the MAINTENANCE section).

## AS REQUIRED

### Auger Gear Box

The auger gear box is lubricated at the factory and should not require additional lubrication.

If for some reason the lubricant should leak out, or if the auger gear box has been serviced, add Lubriplate GR132 Grease or equivalent. Maximum 3-1/4 ounces, (92 grams) should be used.

Remove filler plug D (Figure 21 and Figure 22), once a year. If grease is visible, do not add. If grease is not visible, use a piece of fine wire, like a dipstick to check if there is grease in the gear box. Mobilux EP1 and Shell Aldania EP1 are suitable equivalents.

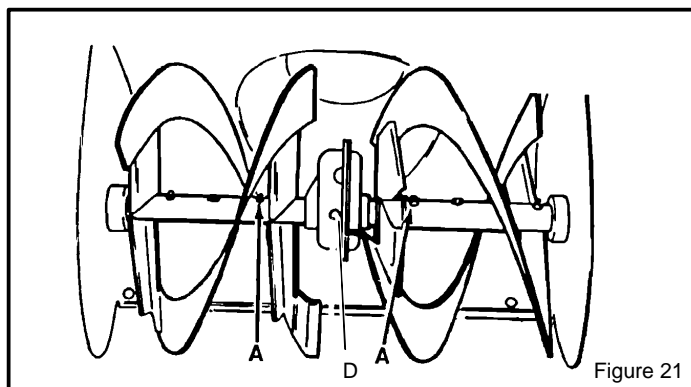

Figure 21

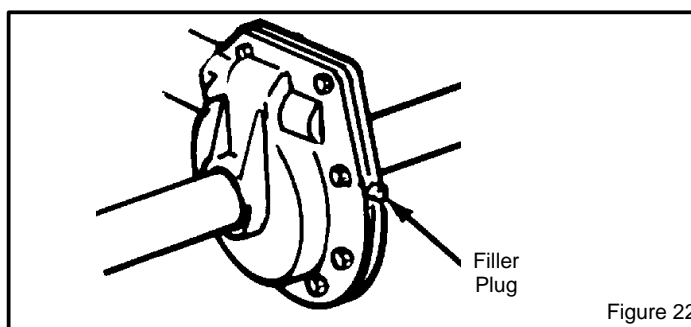

Figure 22

---

## LUBRICATION

### Bearings and bushings

All bearings and bushings are lifetime lubricated and require no maintenance.

### Hex shaft and chains

For storage, the hex shaft should be wiped with a cloth lightly moistened with motor oil to prevent rusting (see Figure 24).

For storage, the chains should be lubricated with a chain type lube. (see Figure 24).

**NOTE: Any greasing or oiling of the above mentioned components can cause contamination of the rubber friction wheel. If the disc drive plate or friction wheel come in contact with grease or oil damage to rubber friction wheel will result .**

If grease or oil comes into contact with the disc drive plate or friction wheel, make sure to clean plate and wheel thoroughly with an alcohol base solvent.

## LUBRICATION - EVERY 10 HOURS

1. **Auger Shaft** - Using a hand grease gun, lubricate the auger shaft zerk fittings (A) every ten (10) operating hours. Each time a shear bolt is replaced, the auger shaft **MUST** be greased (Figure 21). (See To Replace Auger Shear Bolt in the MAINTENANCE section).
2. For storage or when replacing shear bolts, remove shear bolts and lubricate auger shaft zerk. Rotate augers several times on the shaft and reinstall the shear bolts.

# MAINTENANCE

## LUBRICATION - EVERY 25 HOURS

### Chute Rotation Gear

Lubricate the **chute rotation gear** with automotive type oil. (see Figure 23).

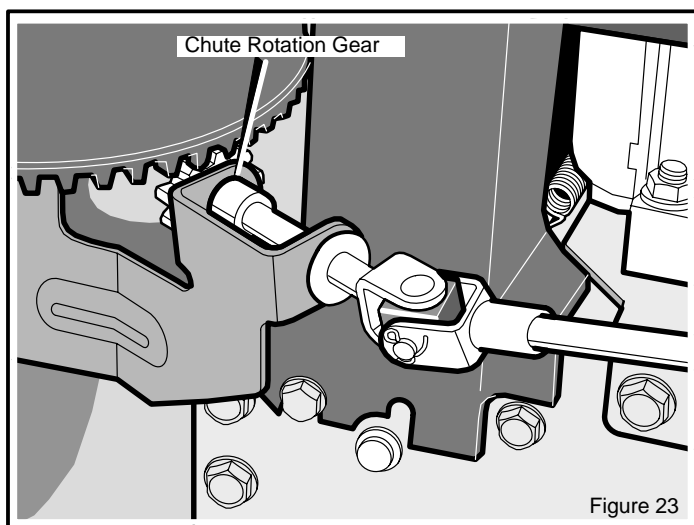

### Chains

1. Position speed selector lever in first (1) forward gear.
2. Stand the snowthrower up on the auger housing end.

**NOTE:** When the crank case is filled with oil, do not leave the snowthrower standing up on the auger housing for an extended period of time.

3. Remove the bottom panel.

4. Lubricate the **chains** with a chain type lubricant.
5. Wipe the **hexshaft and sprockets** with 5W30 motor oil.  
**NOTE:** Clean all excess grease or oil found on the rubber friction wheel or the disc drive plate.  
**CAUTION:** Do not allow grease or oil to contact the rubber friction wheel or the disc drive plate.
6. Install the bottom panel.

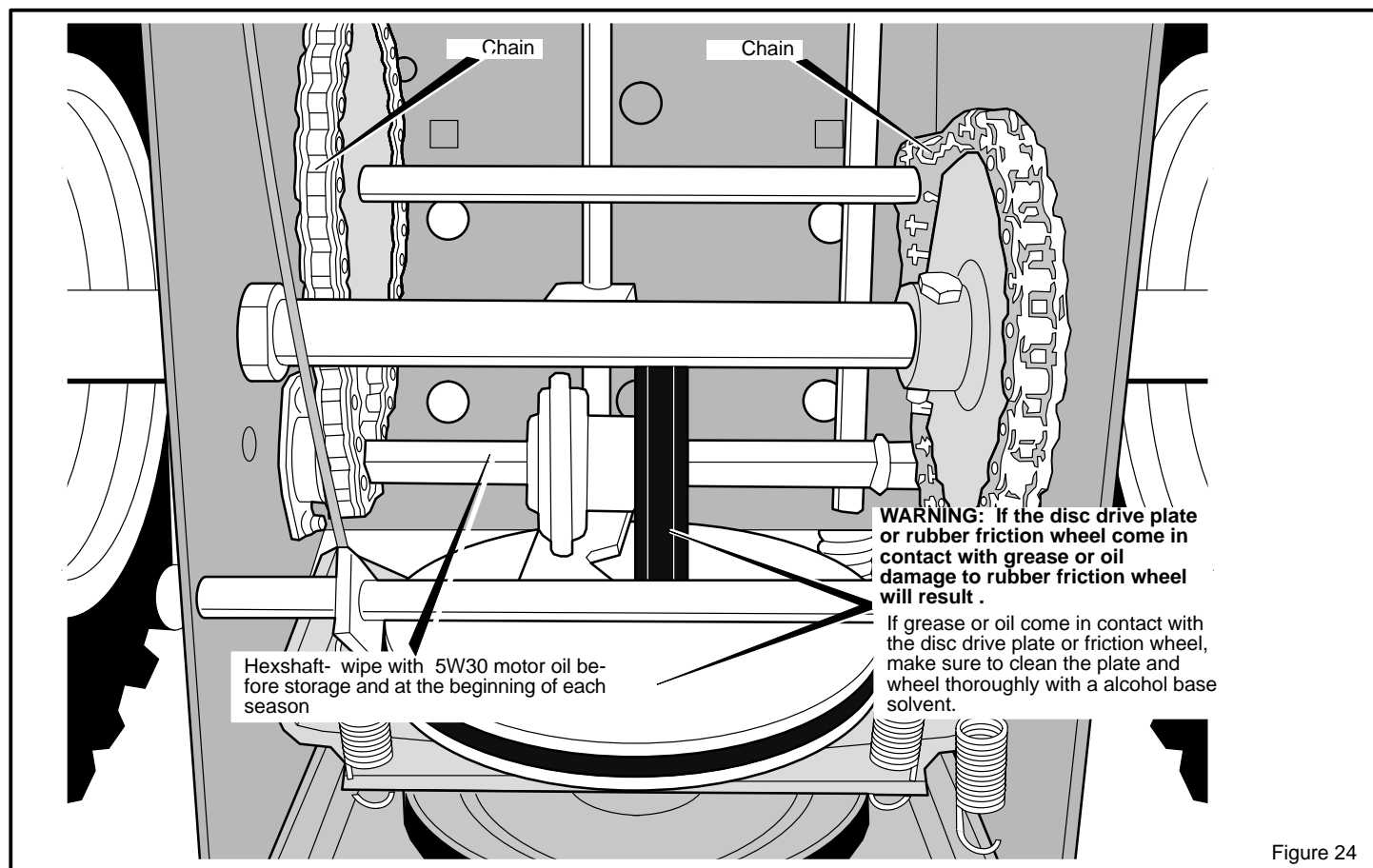

# MAINTENANCE

## ENGINE

**Check Crankcase Oil Level** before starting engine and after each 5 hours of continuous use (see Figure 25). Add proper motor oil as required.

**NOTE: Overfilling the engine can affect performance. Tighten the oil fill cap securely to prevent leakage.**

**Change Oil** every 25 hours of operation or at least once a year, even if the snowthrower is not used for twenty-five hours. Use a clean, high quality detergent oil. Fill the crank case to FULL line on dipstick (see Figure 25). Be sure original container is marked: A.P.I. service "SF" or higher. Do not use SAE 10W40 oil (as it may not provide proper lubrication). See Chart for oil recommendations.

**To Drain Oil** - Position snowthrower so that the oil drain plug is lowest point on engine. Remove oil drain plug and oil fill cap and drain oil into a suitable container (Figure 26).

**NOTE: Oil will drain more freely when warm.**

Replace oil drain plug and tighten securely. Refill crank case with proper motor oil or as indicated in the preceding paragraphs of this section.

TEMPERATURE	TYPE OF OIL
0°F (-18° C) and above	S.A.E. 5W30
0°F (-18° C) and below	synthetic 0W30

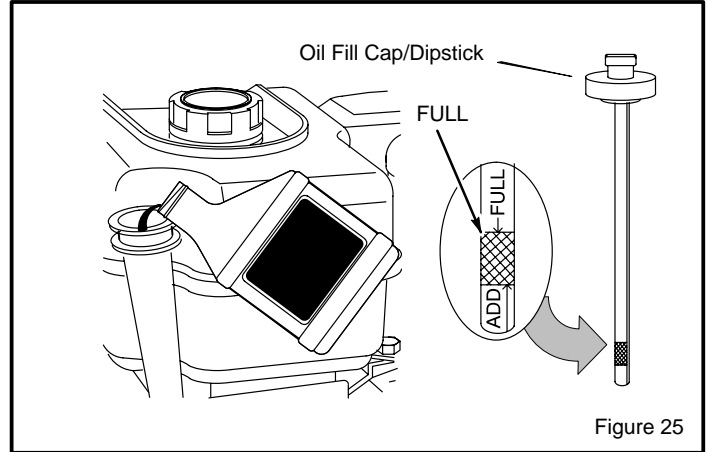
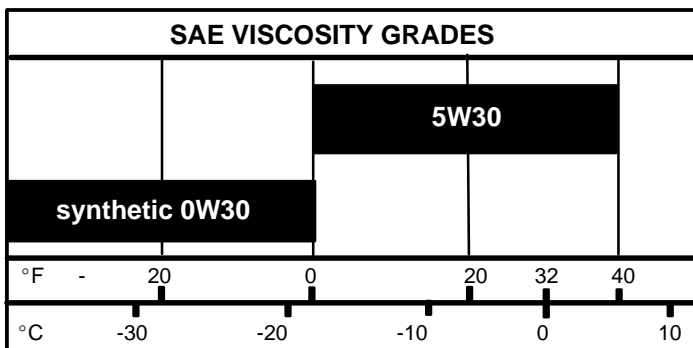

Figure 25

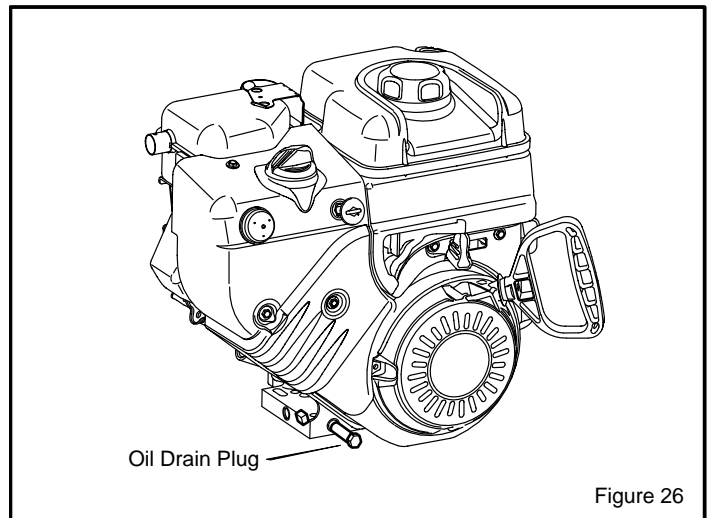

Figure 26

# MAINTENANCE



**WARNING:** Always turn unit off, remove ignition key and disconnect the spark plug wire before making any repairs or adjustments.

## AUGER HOUSING HEIGHT ADJUSTMENT

### TO ADJUST SCRAPER BAR

After considerable use, the metal scraper bar will have a definite wear pattern. The scraper bar in conjunction with the skids should always be adjusted to allow one-eighth of an inch (3 mm) between the scraper bar and the sidewalk or area to be cleaned.

**To adjust the scraper bar, proceed as follows:**

1. Position the snowthrower on a level surface.
2. Loosen the carriage bolts and nuts securing the scraper bar to the auger housing.
3. Adjust the scraper bar to the proper position. Tighten the carriage bolts and nuts, insuring that the scraper bar is parallel with the working surface.
4. For extended operation, the scraper bar may be reversed. If the scraper bar must be replaced because of wear, remove the carriage bolts and nuts and install a new scraper bar.

### TO ADJUST SKID HEIGHT

This snowthrower is equipped with two height adjust skids, secured to the outside of the auger housing. These elevate the front of the snowthrower.

When removing snow from a hard surface area such as a paved driveway or walk, adjust the skids up to bring the front of the snowthrower down.

When removing snow from rock or uneven construction, raise the front of the snowthrower by moving the skids down. This will help to prevent rocks and other debris from being picked up and thrown by the augers.

**To adjust skids, proceed as follows:**

1. Place a block (equal to height from ground desired) under scraper bar near but not under skid.
2. Loosen skid mounting nuts (Figure 27) and push the skid down until it touches the ground. Retighten mounting nuts.
3. Set skid on other side at same height.

**NOTE:** Make sure that snowthrower is set at same height on both sides.



**WARNING:** Be certain to maintain proper ground clearance for your particular area to be cleared. Objects such as gravel, rocks or other debris, if struck by the impeller, may be thrown with sufficient force to cause personal injury, property damage or damage to the snowthrower.

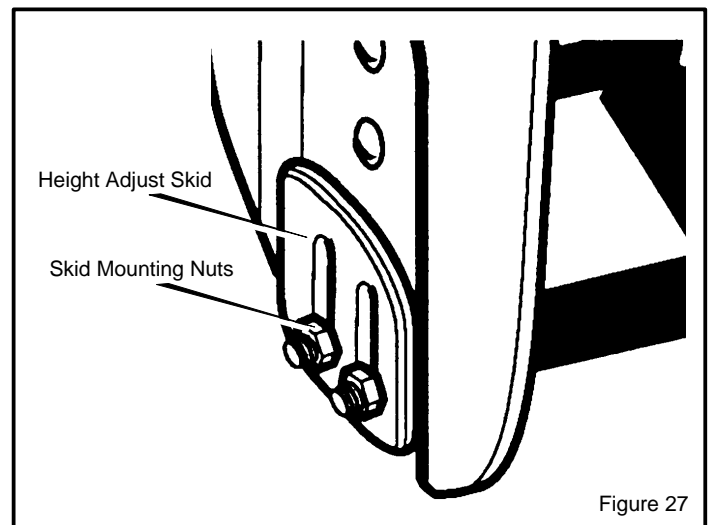

Figure 27

# MAINTENANCE

## BELT ADJUSTMENT

### Traction Drive Belt

The traction drive belt has constant spring pressure and does not require an adjustment. If the traction drive belt is slipping, replace the belt. See "How To Replace The Belts" in the Maintenance section.

### Auger Drive Belt

If your snowthrower will not discharge snow, check the control cable adjustment. If it is correct, then check the condition of the auger drive belt. If it is damaged or loose, replace it (see Belt Replacement in this section of the manual).

1. Disconnect spark plug wire.
2. Remove **screw** from **belt cover**. Remove **belt cover** (see Figure 28).
3. Loosen nut on auger idler pulley and move auger idler pulley towards belt about 1/8 inch (3 mm) (see Figure 31).
4. Tighten nut.
5. Have someone engage auger drive clutch. Check tension on belt (opposite idler pulley). Belt should deflect about 1/2 inch (12.5 mm) with moderate pressure (Figure 29). You may have to move idler pulley more than once to obtain the correct tension.
6. Reinstall belt cover.
7. Whenever belts are adjusted or replaced, the cables will need to be adjusted. (See Cable Adjustment in this section of the manual).
8. Attach the spark plug wire.

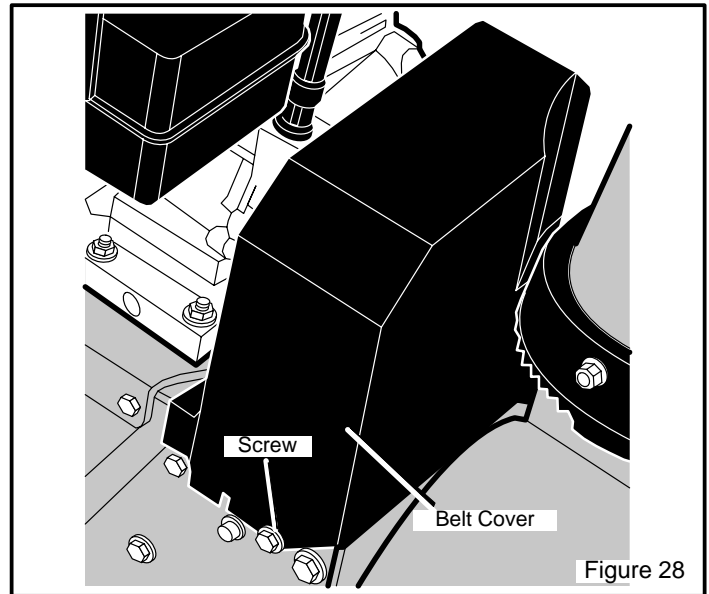

Figure 28

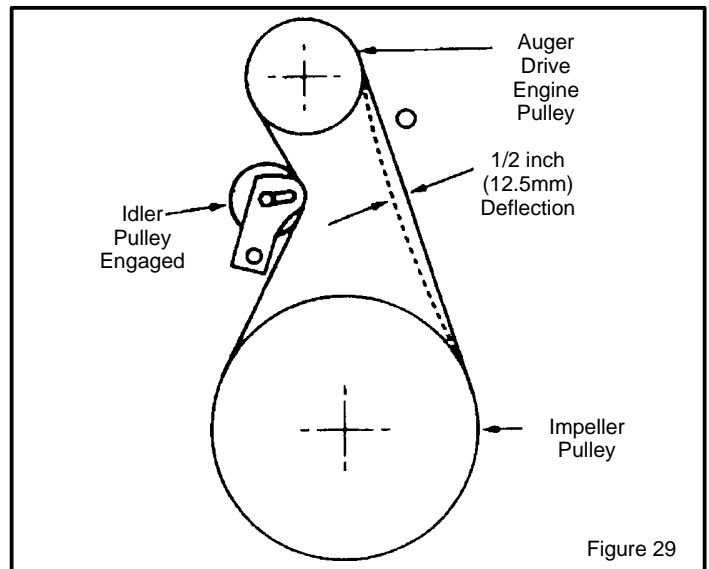

Figure 29



# MAINTENANCE

## HOW TO REPLACE THE BELTS

The drive belts are of special construction and must be replaced with original factory replacement belts available from your nearest authorized service center.

Some steps require the assistance of a second person.

### How To Remove the Auger Drive Belt

If the auger drive belt is damaged, the snow thrower will not discharge snow. Replace the damaged belt as follows.

1. Disconnect the spark plug wire.
2. Loosen the **bolts** on each side of the **bottom panel** (see Figure 30).
3. Remove the **bottom panel**.
4. Remove **screw** from **belt cover**. Remove the **belt cover** (see Figure 28).
5. Loosen the **belt guide**. Pull the **belt guide** away from the **auger drive pulley** (see Figure 31).
6. Pull the **idler pulley** away from the **auger drive belt**.
7. Remove the old **auger drive belt** from the **auger drive pulley** and from the **engine pulley**. Replace the **auger drive belt** with an original factory replacement belt available from an authorized service center.
8. Install the new **auger drive belt** onto the **auger drive pulley** and onto **pulley**.

9. Adjust the **auger drive belt**. See "How To Adjust The Auger Drive Belt" in the Maintenance section.
10. Adjust the **belt guide**. See "How To Adjust The Belt Guide" in the Maintenance section.
11. Install the **belt cover**. Tighten **screw** (See Figure 28).
12. Check the adjustment of the cables. See "How To Check And Adjust The Cables" in the Maintenance section.
13. Install the **bottom panel** (see Figure 30).
14. Tighten the **bolts** on each side of the **bottom panel**.
15. Connect the spark plug wire.

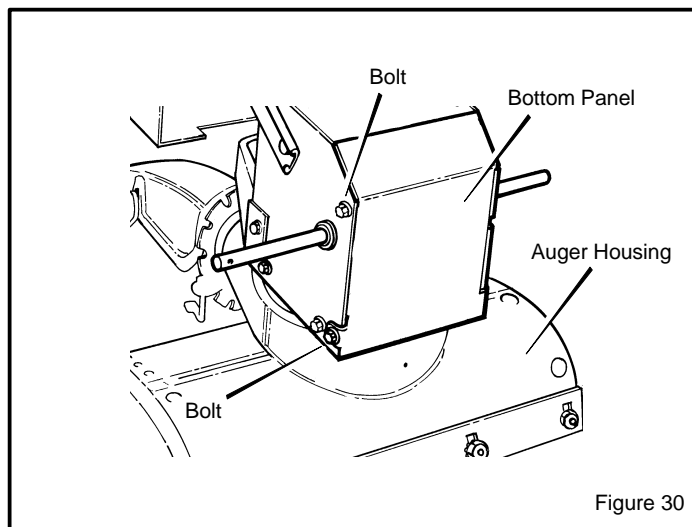

Figure 30

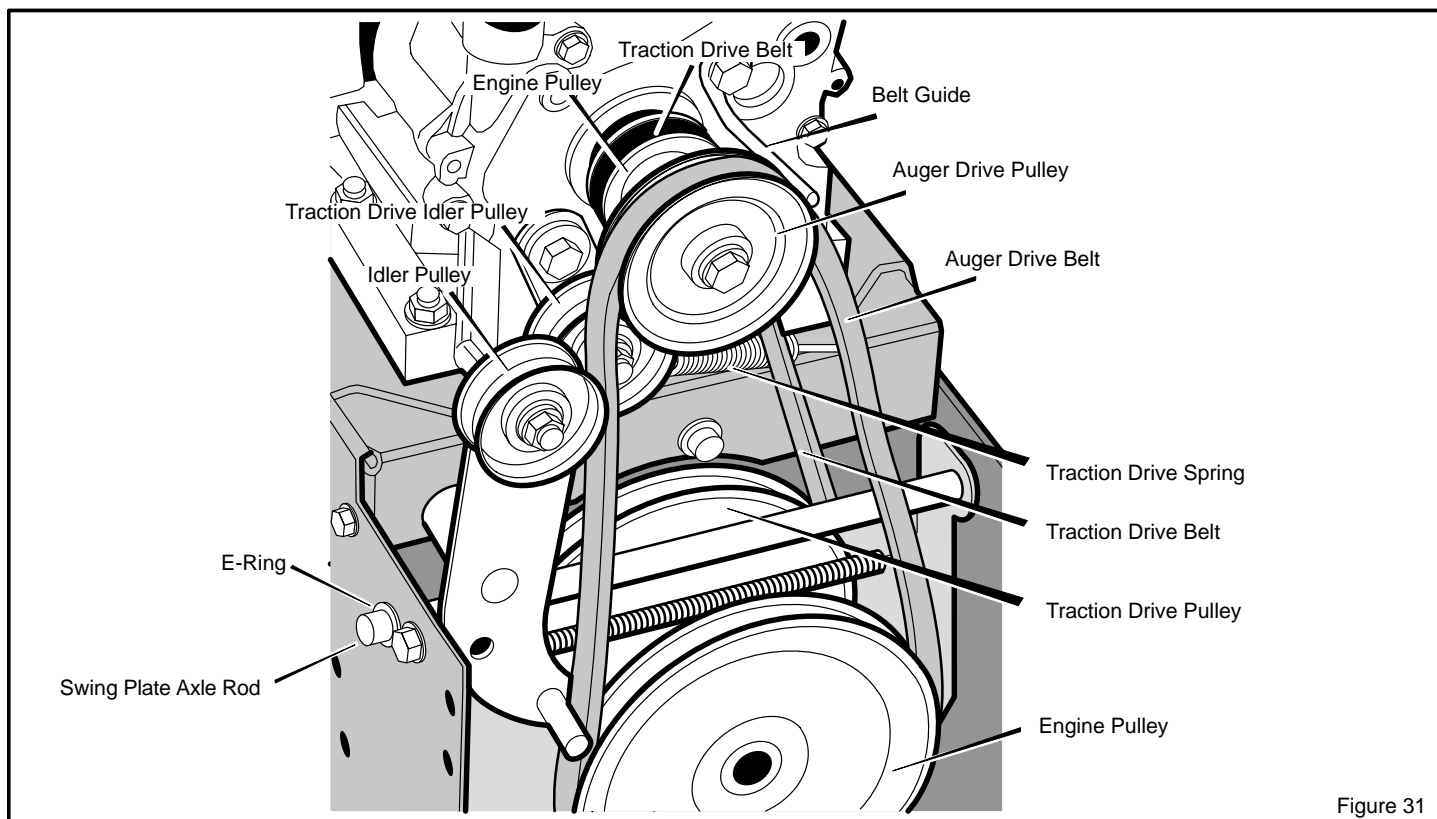

Figure 31

# MAINTENANCE

## How To Remove the Traction Drive Belt

If the snow thrower will not move forward, check the traction drive belt for wear or damage. If the traction drive belt is worn or damaged, replace the belt as follows.

1. Disconnect the spark plug wire.
2. Remove the auger drive belt. See “How To Remove The Auger Drive Belt” in the Maintenance section.
3. Remove the **e-ring** from one end of the **swing plate axle rod**. Remove the **swing plate axle rod** to allow the swing plate to pivot forward (see Figure 31).
4. Remove the **traction drive spring**.
5. Remove the old **traction drive belt** from the **traction drive pulley** and from the **engine pulley**. Replace the **traction drive belt** with an original factory replacement belt available from an authorized service center.
6. Install the new **traction drive belt** onto the **traction drive pulley** and onto **engine pulley**.
7. Make sure the **traction drive idler pulley** is properly aligned with the **traction drive belt**.
8. Attach the **traction drive spring**.
9. Install the **swing plate axle rod** and secure with the **e-ring** removed earlier.
10. The bottom of the **swing plate** must be positioned between the **alignment tabs**. Make sure the **swing plate** is properly secured (see Figure 32).
11. Install and adjust the **auger drive belt**. See “How To Remove The Auger Drive Belt” in the Maintenance section.
12. Adjust the **belt guide**. See “How To Adjust The Belt Guide” in the Maintenance section.
13. Install the **bottom panel** (see Figure 30).
14. Tighten the **bolts** on each side of the **bottom panel**.
15. Install the **belt cover**. Tighten **screw** (see Figure 28).
16. Check the adjustment of the cables. See “How To Check And Adjust The Cables” in the Maintenance section.
17. Connect the spark plug wire.

**NOTE:** If the drive will not engage after the traction drive belt has been replaced, then check to make sure that the swing plate is positioned between the alignment tabs.

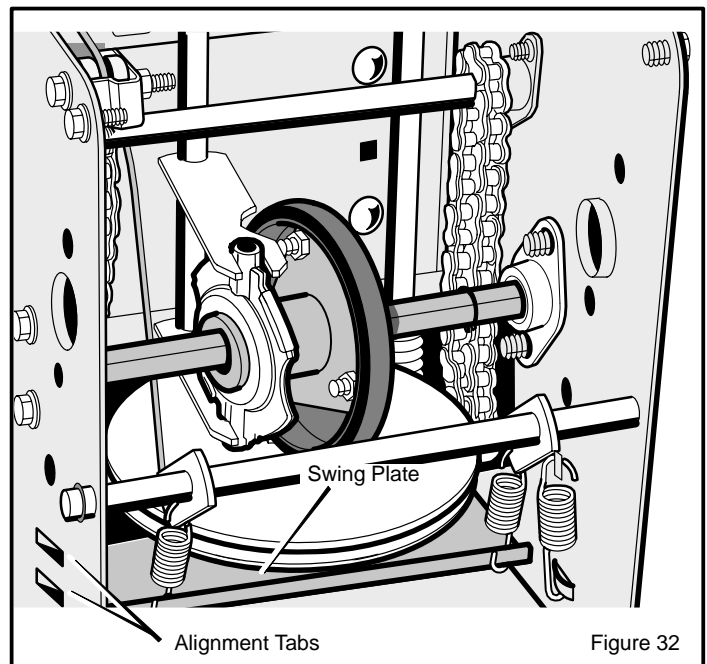

# MAINTENANCE

## BELT GUIDE ADJUSTMENT

1. Remove spark plug wire.
2. Have someone engage auger drive.
3. Measure the distance between the belt guide and belt. The distance should be 1/8 inch (3.175 mm) for guide. See Figure 33.
4. If adjustment is necessary, loosen belt guide mounting bolt. Move belt guide to the correct position. Tighten mounting bolt.
5. Reinstall belt cover.
6. Reconnect spark plug wire.

## HOW TO CHECK AND ADJUST THE CABLES

The cables are adjusted at the factory and no adjustment should be necessary. If the cables have become stretched or are sagging adjustment will be necessary.

Whenever belts are adjusted or replaced, the cables will need to be adjusted.

1. Move clutch lever to the full forward position (just contacting plastic bumper). Holding cable tight, note position of fitting to hole in clutch lever.
2. The center of the "Z" fitting should be between the centre and top of the hole in the clutch lever. Adjust either the auger drive cable or the traction drive cable as follows.

### Auger Drive Cable Adjustment



**WARNING: Drain the gasoline outdoors, away from fire or flame.**

1. Remove the gas from the gas tank. Stand the snow thrower up on the front end of the auger housing.
2. Push cable through spring to expose the threaded portion of the cable (see Figure 34).
3. Hold square end of threaded portion with pliers and adjust locknut in or out until correct adjustment is reached. Pull cable back through spring and connect cable.

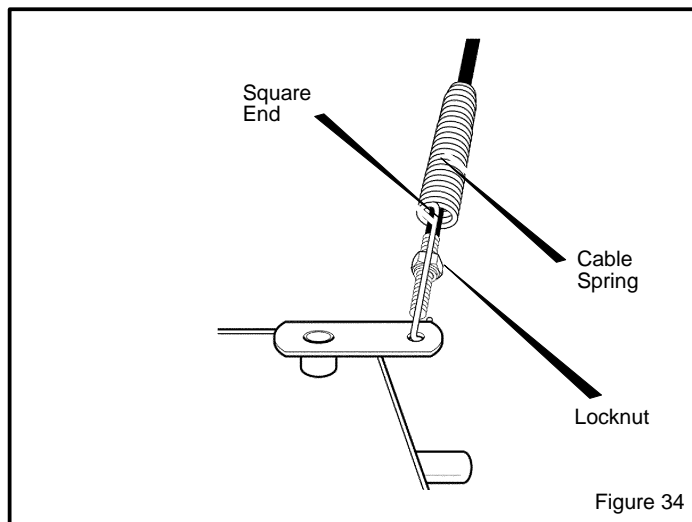
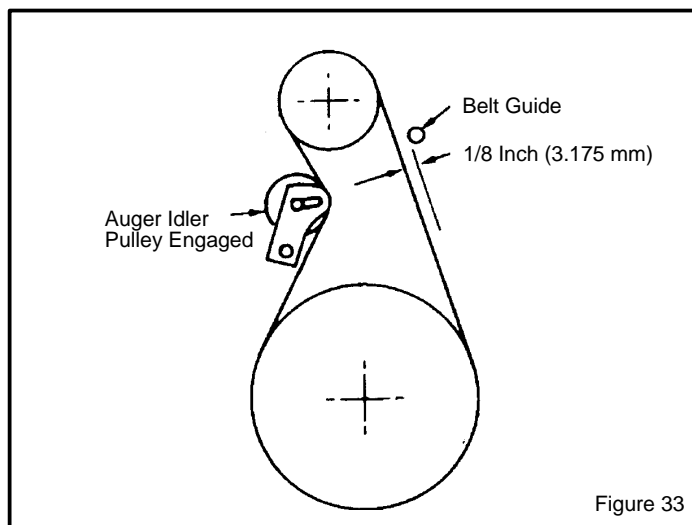

# MAINTENANCE

## Traction Drive Cable Adjustment



**WARNING:** Drain the gasoline outdoors, away from fire or flame.

1. Remove the gas from the gas tank. Stand the snow thrower up on the front end of the auger housing.
2. Loosen the **bolts** on each side of the **bottom panel** (see Figure 35).
3. Remove the **bottom panel**.
4. Slide the **cable boot** off the **cable adjustment bracket** (see Figure 36).
5. Push the bottom of the **traction drive cable** through the **cable adjustment bracket** until the "**Z**" hook can be removed.
6. Remove the "**Z**" hook from the **cable adjustment bracket**. Move the "**Z**" hook down to the next adjustment hole.
7. Pull the **traction drive cable** up through the **cable adjustment bracket**.
8. Put the **cable boot** over the **cable adjustment bracket**.
9. To check the adjustment, depress the drive lever and check the length of the **drive spring** (see Figure 37). In correct adjustment, the length of the **drive spring** is minimum 3 inches (76 mm.) maximum 3-3/8 inches (85 mm.).
10. Install the **bottom panel** (see Figure 35).
11. Tighten the **bolts** on each side of the **bottom panel**.

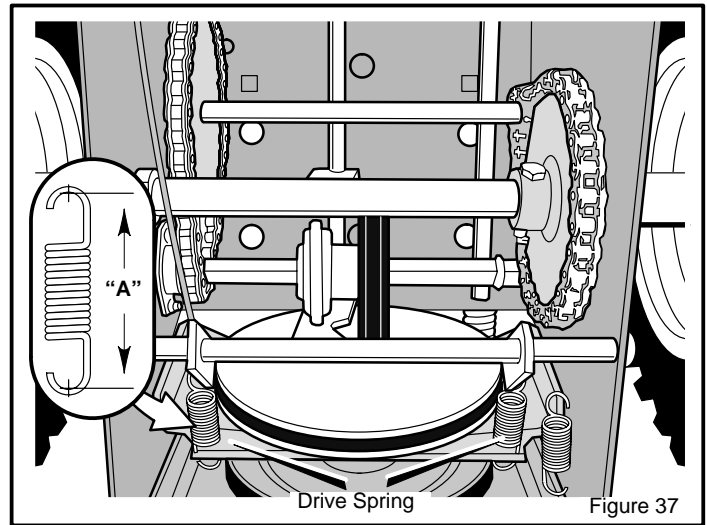
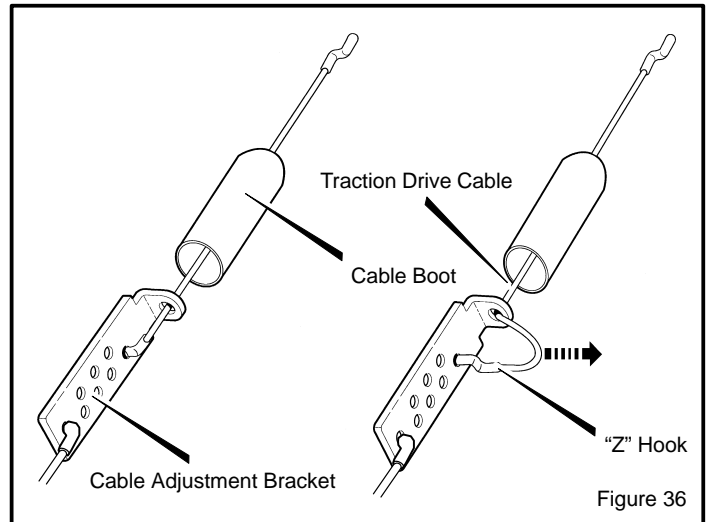
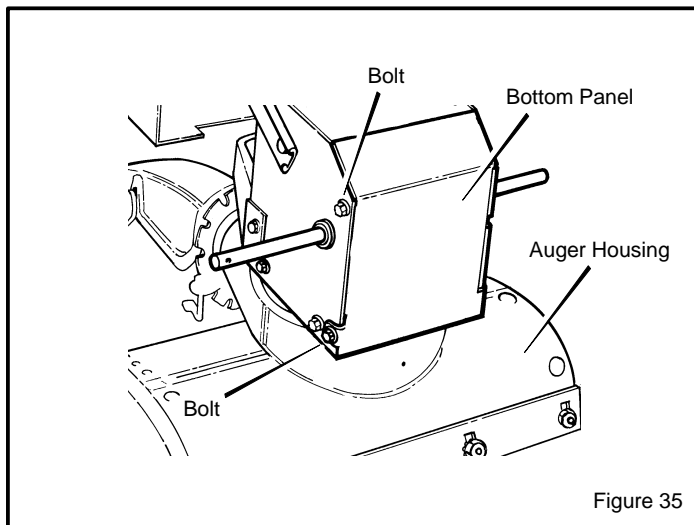

# MAINTENANCE

## HOW TO ADJUST OR REPLACE THE FRICTION WHEEL

### How To Check The Friction Wheel

If the snow thrower will not move forward, check the traction drive belt, the traction drive cable or the friction wheel. If the friction wheel is worn or damaged, it must be replaced. See "How To Replace the Friction Wheel" in this section. If the friction wheel is not worn or damaged, check as follows.

1. Remove the gas from the gas tank. Stand the snow thrower up on the front end of the **auger housing** (see Figure 38).



**WARNING: Drain the gasoline outdoors, away from fire or flame.**

2. Disconnect the spark plug wire.
3. Loosen the **bolts** on each side of the **bottom panel** (see Figure 38).
4. Remove the **bottom panel**.
5. Position the **shift speed lever** in the lowest forward speed.
6. Note the position of the **friction wheel** (see Figure 39). The correct distance "A" from the right side of the **friction wheel** to the outside of the motorbox is as follows:

Tire Size	Distance "A"
12 and 13 inch	4-1/8" (10.5 cm.)
16 inch	4-5/16" (10.95 cm.)

If the **friction wheel** is not in the correct position, adjust as follows.

### How To Adjust The Friction Wheel

1. Position the **shift speed lever** in the lowest forward speed.
2. Loosen hex **jam nut** on **speed select rod**. Remove **ball joint** from **shifter rod** (see Figure 40).
3. Move the **friction wheel** to the correct position (see Figure 39).
4. Turn the **adaptor** until the **ball joint** is aligned with the mounting hole in the **shifter rod** (see Figure 40). When aligned, attach the **ball joint** to the **shifter rod**.

5. Tighten the **jam nut**.
6. Install the **bottom panel** (see Figure 38).
7. Tighten the **bolts** on each side of the **bottom panel**.

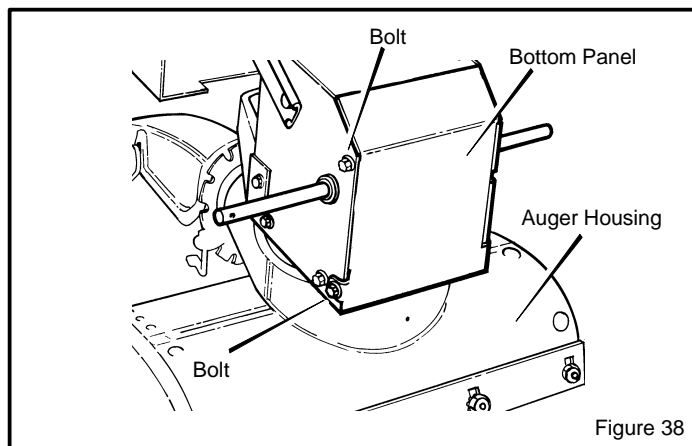

Figure 38

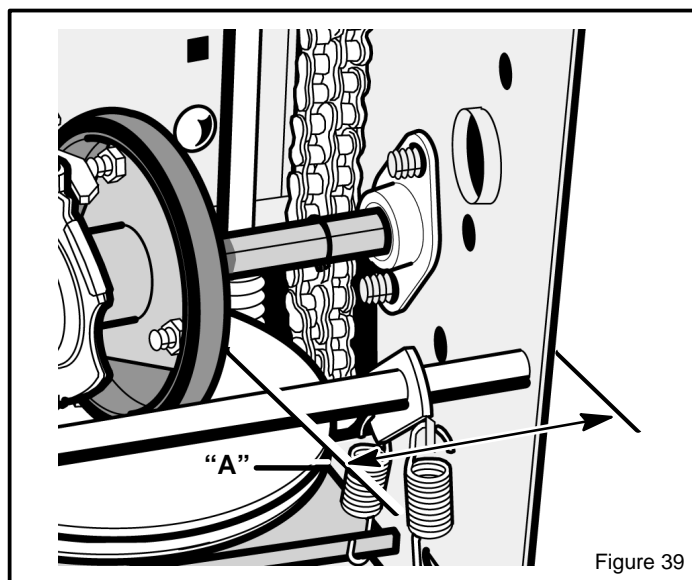

Figure 39

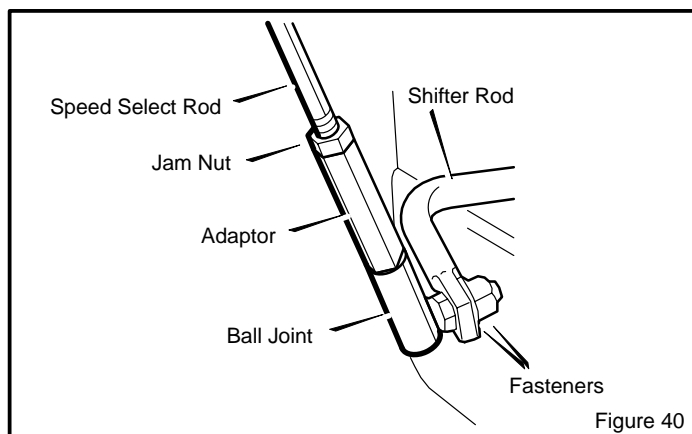

Figure 40

# MAINTENANCE

## How To Replace The Friction Wheel

If the friction wheel is worn or damaged, the snow thrower will not move forward. The friction wheel must be replaced as follows.

1. Remove the gas from the gas tank. Stand the snow thrower up on the front end of the **auger housing (4)**. (see Figure 38).



**WARNING: Drain the gasoline outdoors, away from fire or flame.**

2. Disconnect the spark plug wire.
3. Remove the fasteners that secure the left **wheel**. Remove the **left wheel** from the **axle** (see Figure 41)
4. Loosen the **bolts** on each side of the **bottom panel**.
5. Remove the **bottom panel**.

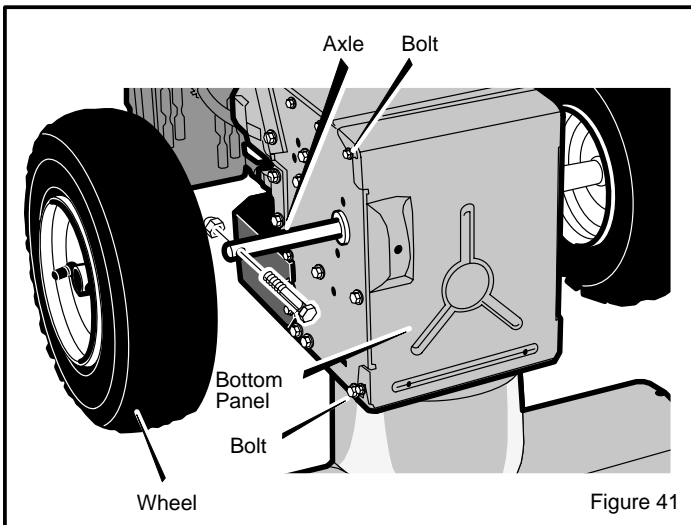

6. Remove the fasteners that secure the **drive sprocket** to the **axle** (see Figure 42).
7. Remove the right wheel, **axle**, and **drive sprocket**.

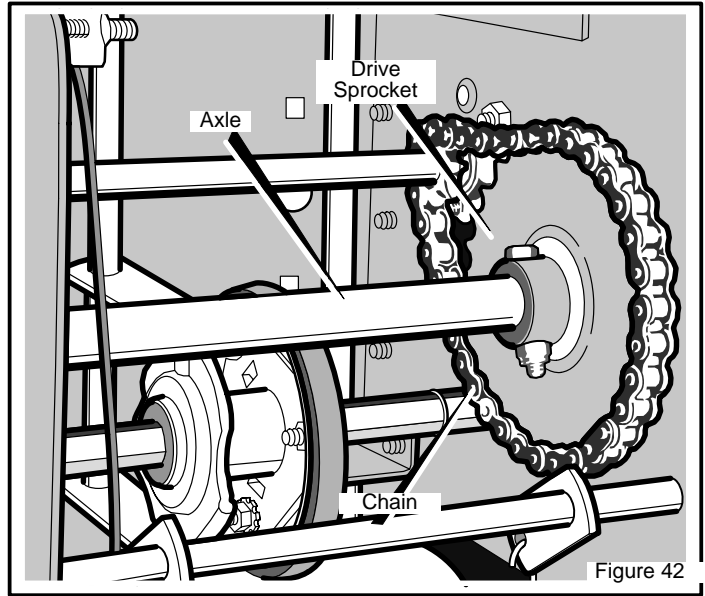

8. Remove the four **bolts** that hold the **bearings** on each side of the **hex shaft** (see Figure 43).
9. Remove the **hex shaft** and **bearings**.

**NOTE: Take special note of the position of the washers on the hex shaft.**

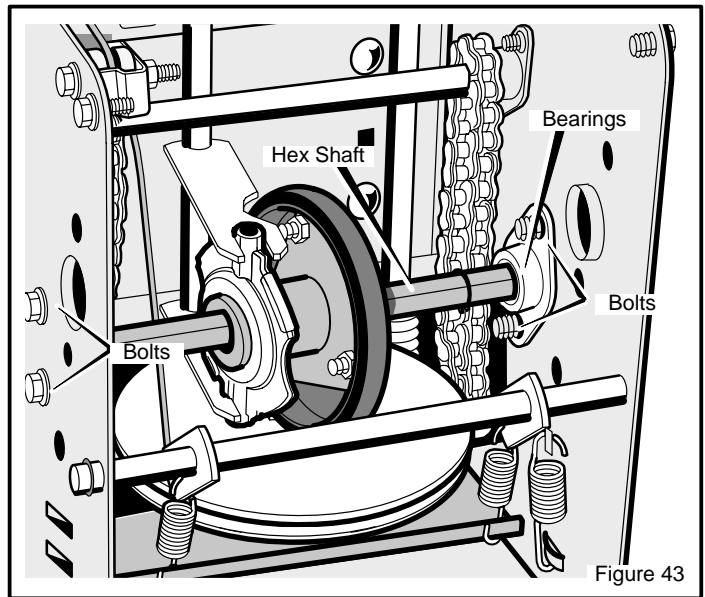

# MAINTENANCE

10. Remove the three **fasteners** that hold the **friction wheel** to the **hub** (see Figure 44).
11. Remove the **friction wheel** from the **hub**. Slip the **friction wheel** off the **hex shaft**.
12. Assemble the new **friction wheel** onto **hub** with the fasteners removed earlier.

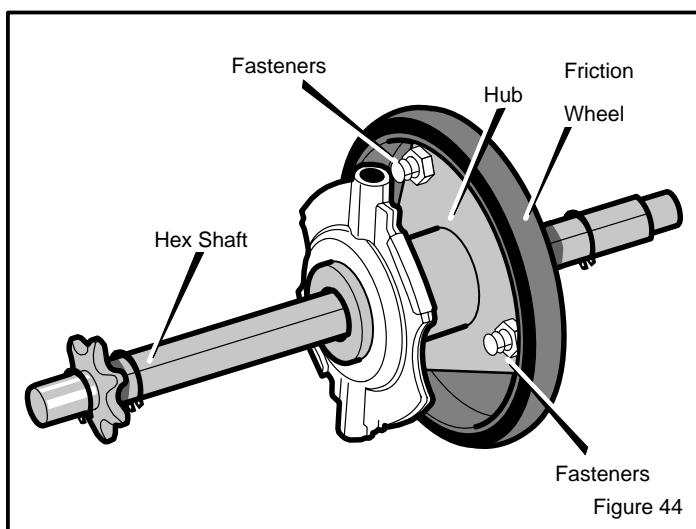

13. Install the **hex shaft** and **bearings** with the four bolts removed earlier (see Figure 45).

**Make sure the washers are properly installed in the original position. Also, make sure the two washers are properly aligned with the actuator arms.**

14. Make sure the **hex shaft** turns freely.

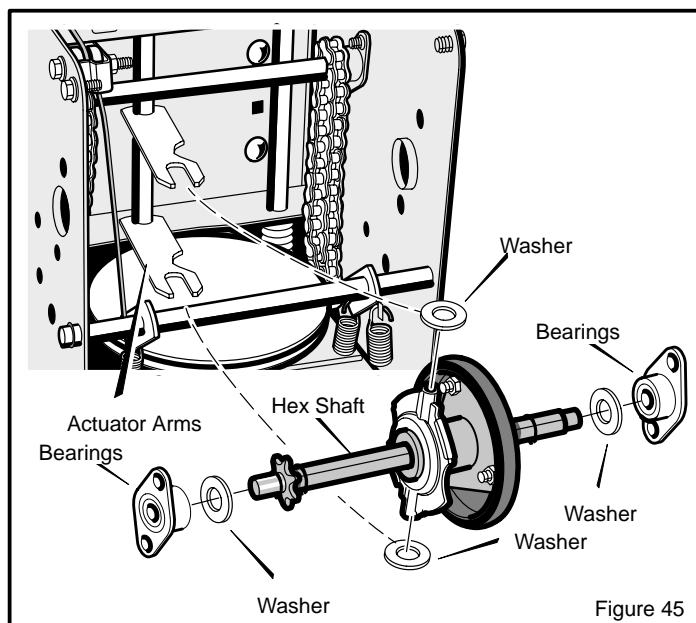

15. Install the right wheel, **axle**, and **drive sprocket** with the fasteners removed earlier. Install the **chain** onto the **drive sprocket** (see Figure 42).
16. Check the adjustment of the friction wheel. See "How To Adjust The Friction Wheel" in this section.
17. Make sure the friction wheel and the disc drive plate are free from grease or oil.
18. Install the **bottom panel** (see Figure 41).
19. Tighten the **bolts** on each side of the **bottom panel**.
20. Install the **left wheel** to the **axle** with the fasteners removed earlier.
21. Connect the spark plug wire.

# MAINTENANCE

## HOW TO REMOVE THE SNOW HOOD

To access the spark plug, the snow hood must be removed as follows:

1. Remove the choke control knob (see Figure 46).
2. Remove the ON/OFF key.
3. Remove the four mounting screws.
4. Slowly remove the snow hood (see Figure 47). Make sure that the primer button hose and the ignition wire are not disconnected.
5. To install the snow hood, first make sure that the primer button hose and the ignition wire are connected.
6. Mount the snow hood to the engine and secure with the four mounting screws (see Figure 48).
7. Align the tab on the choke control knob with the slot in the snow hood (see Figure 49).
8. Connect the choke control knob with the choke shaft. Make sure the choke control knob is properly installed. If the choke control knob is not installed correctly, the choke will not operate.

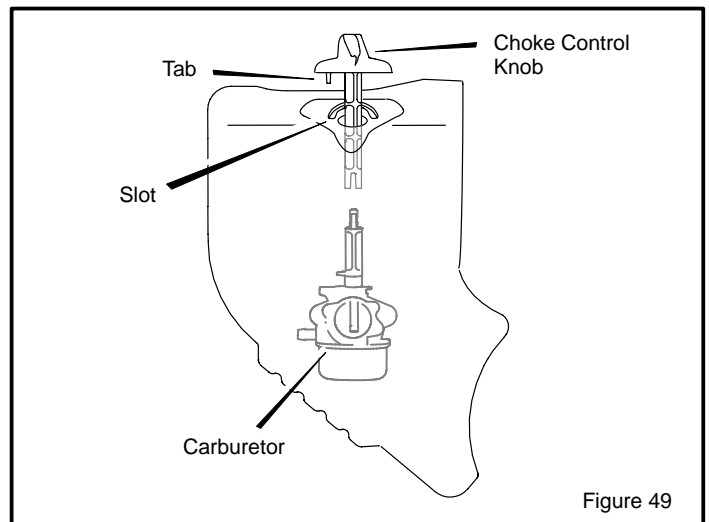
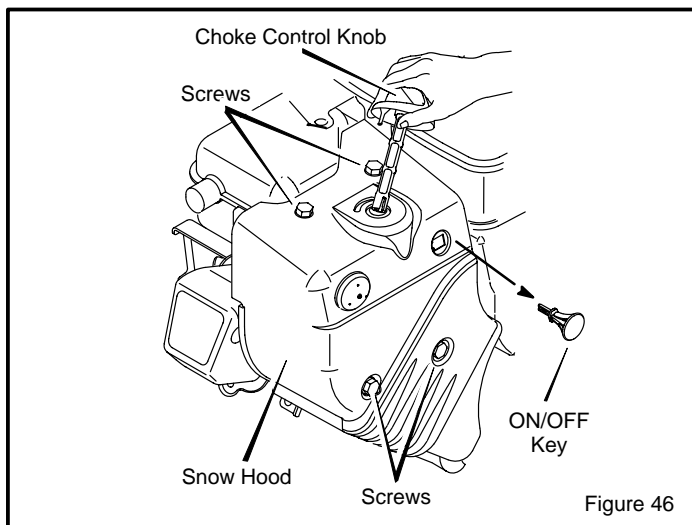
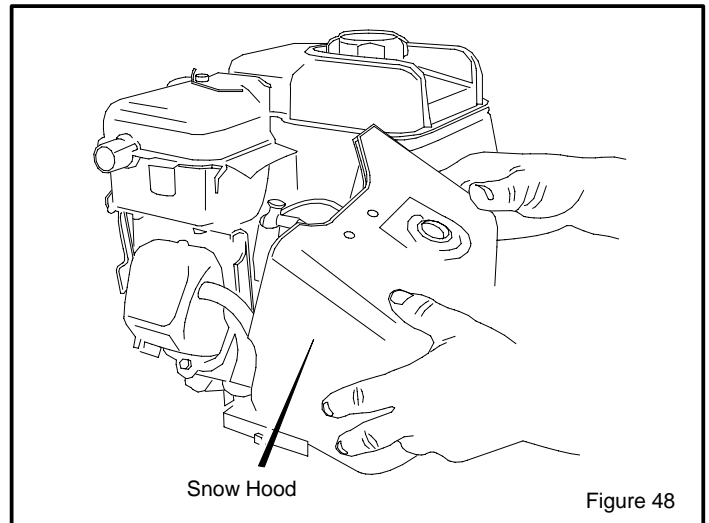
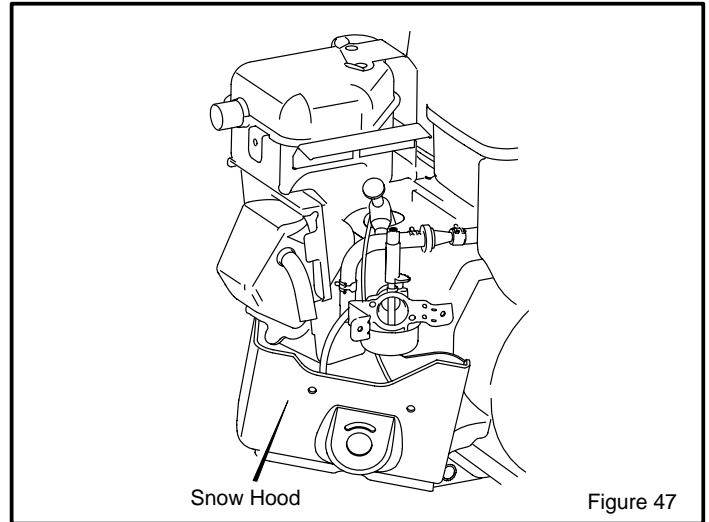



# MAINTENANCE

## AUGER SHEAR BOLT REPLACEMENT

The augers are secured to the auger shaft with special bolts that are designed to break if an object becomes lodged in the auger housing. Use of a harder bolt will reduce the protection provided by the shear bolt. To replace a broken shear bolt, proceed as follows:



**WARNING:** To insure safety and performance levels, only original replacement shear bolts should be used.

1. Move throttle to STOP, disengage all controls, disconnect the spark plug lead wire, and insure all moving parts have stopped.
2. Lubricate the auger shaft zerk fittings (see Lubrication Points in the Maintenance section of this manual).
3. Align the hole in the auger with the hole in the auger shaft. Install new shear bolt, spacer and locknut found in the toolbox located on the belt cover (See Figure 50).

**NOTE:** The spacer fits into the larger hole in the auger tube.

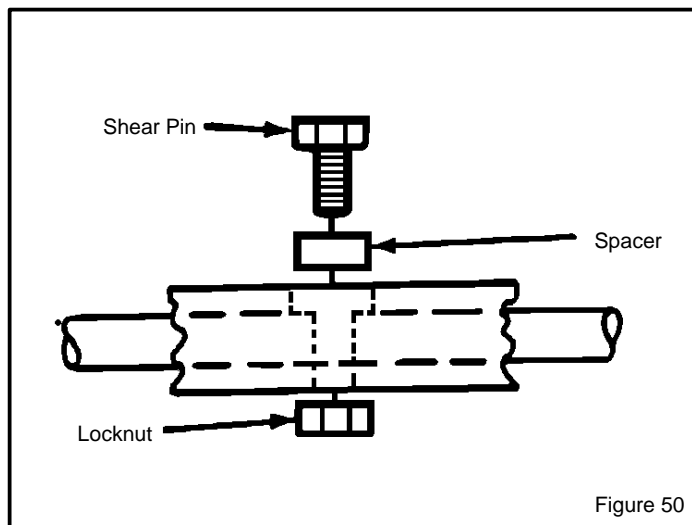

Figure 50

## TO ADJUST OR REPLACE THE SPARK PLUG

Check the **spark plug** every twenty-five (25) hours. Replace the **spark plug** if the electrodes are pitted or burned or if the porcelain is cracked.

1. Clean spark plug and reset gap periodically.
2. Clean area around spark plug base before removal, to prevent dirt from entering engine.
3. Replace spark plug if electrodes are pitted or burned or if porcelain is cracked.
4. Clean spark plug by carefully scraping electrodes (do not sandblast or use wire brush).
5. Be sure spark plug is clean and free of foreign material. Check electrodes gap with a wire feeler gauge and reset gap to 0.030" (0.76 mm) if necessary. If a new spark plug is needed, refer to Engine Repair Parts section of this manual for proper replacement spark plug.
6. Before installing spark plug, coat threads lightly with graphite grease to insure easy removal.

7. Tighten plug firmly into engine. If torque wrench is available, torque plug to 18-23 ft-lbs.

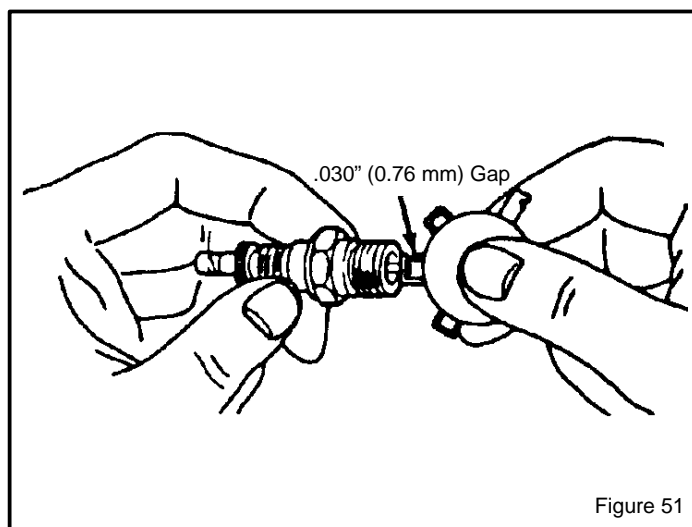

Figure 51

---

# STORAGE

---

## OFF SEASON STORAGE



**WARNING:** Never store the engine, with fuel in the tank, indoors or in a poor ventilated enclosure where fuel fumes could reach an open flame, spark or pilot light as on a furnace, water heater, clothes dryer, etc.

Handle gasoline carefully. It is highly flammable and careless use could result in serious fire damage to your person and/or property.

Drain fuel into approved containers outdoors, away from open flame.

If the snowthrower is to be stored for thirty (30) days or more at the end of the snow season, the following steps are recommended to prepare your snowthrower for storage.

**NOTE:** Gasoline must be removed or treated to prevent gum deposits from forming in the tank, filter, hose, and carburetor during storage.

1. To remove gasoline, run engine until tank is empty and engine stops.

If you do not want to remove the gasoline, add fuel stabilizer to any gasoline left in the tank to minimize gum deposits and acids. If the tank is almost empty, mix stabilizer with fresh gasoline in a separate container and add some to the tank. ALWAYS FOLLOW INSTRUCTIONS ON STABILIZER CONTAINER. THEN RUN ENGINE AT LEAST 10 MINUTES AFTER STABILIZER IS ADDED TO ALLOW MIXTURE TO REACH CARBURETOR. STORE SNOWTHROWER IN SAFE PLACE.

2. You can help keep your engine (4-cycles only) in good operating condition by changing oil before storage.
3. Lubricating the piston/cylinder area. This can be done by first removing the spark plug and squirting clean engine oil into the spark plug hole. Then cover the spark plug hole with a rag to absorb oil spray. Next, rotate the engine by pulling the starter two or three times. Finally, reinstall spark plug and attach spark plug wire.

4. Thoroughly clean the snowthrower.
5. Lubricate all lubrication points (see "Lubrication" in the Maintenance section).
6. Insure that all nuts, bolts, and screws are securely fastened. Inspect all visible moving parts for damage, breakage, and wear. Replace if necessary.
7. Touch up all rusted or chipped paint surfaces; sand lightly before painting.
8. Cover the bare metal parts of the blower housing auger, and the impeller with rust preventative.
9. If possible, store your snowthrower indoors and cover it to give protection from dust and dirt.
10. On models with folding handles, loosen the knobs that secure the upper handle. Rotate the upper handle back.
11. If the machine must be stored outdoors, block up the snowthrower and insure the entire machine is off the ground. Cover the snowthrower with a heavy tarpaulin.

## REMOVING THE SNOWTHROWER FROM STORAGE

When removing the snowthrower from storage, follow the steps below.

1. Put the upper handle in the operating position, tighten the knobs that secure the upper handle.
2. Fill the fuel tank with a fresh fuel.
3. Check the spark plug. Make sure the gap is correct. If the spark plug is worn or damaged, replace before using.
4. Make sure all fasteners are tight.
5. Make sure all guards, shields, and covers are in place.
6. Make sure all adjustments are correct.

# TROUBLE SHOOTING CHART

PROBLEM	LOOK FOR	REMEDY
<b>Difficult starting</b>	Defective spark plug.	Replace defective spark plug.
<b>Engine runs erratically</b>	Blocked fuel line.	Clean fuel line.
	Empty gas tank.	Check fuel supply,
	Stale gasoline.	Add fresh gasoline with fuel stabilizer.
	Water or dirt in fuel system.	Remove carburetor bowl to drain fuel tank. Refill with fresh fuel. <b>CAUTION: Do not remove carburetor bowl when the engine is hot.</b>
<b>Engine stalls</b>	Unit running on CHOKE.	Set choke lever to RUN position.
<b>Loss of power</b>	Gas cap vent hole is plugged.	Remove ice and snow from cap. Be sure vent hole is clear.
<b>Excessive vibration</b>	Loose parts or damaged impeller.	Stop engine immediately and remove spark plug wire. Tighten all bolts and make all necessary repairs. If vibration continues, have the unit serviced by a competent repairman.
<b>Unit fails to propel itself</b>	Drive belt loose or damaged.	Replace drive belt. Refer to <b>Drive Belt Replacement</b> in the <b>Maintenance</b> section of this manual.
	Incorrect adjustment of traction drive cable.	Adjust traction drive cable. Refer to <b>Cable Adjustment</b> in the <b>Maintenance</b> section of this manual.
	Worn or damaged friction disc.	Replace friction disc. Refer to <b>Friction Wheel Replacement</b> in the <b>Maintenance</b> section of this manual.
<b>Unit fails to discharge snow</b>	Auger drive belt loose or damaged.	Replace or adjust auger drive belt. Refer to <b>Drive Belt Replacement</b> and <b>Drive Belt Adjustment</b> in the <b>Maintenance</b> section of this manual.
	Auger control cable not adjusted correctly.	Adjust auger control cable. Refer to <b>Cable Adjustment</b> in the <b>Maintenance</b> section of this manual.
	Broken shear bolt.	Replace shear bolt. Refer to <b>Auger Shear Bolt Replacement</b> in the <b>Maintenance</b> section of this manual.
	Discharge chute clogged.	Stop engine immediately and disconnect spark plug wire. Refer to the first <b>Warning in Snow blower Operation</b> in the <b>Operation</b> section of this manual. Clean discharge chute and inside of auger housing.
	Foreign object lodged in auger.	Stop engine immediately and disconnect spark plug wire. Refer to the <b>third Warning in Snow blower Operation</b> in the <b>Operation</b> section of this manual. Remove object from auger.

## Identifying Your Snow blower

Your new Snow blower has two (2) identifying numbers: (1) unit model number: (2) unit serial number. The two preceding numbers are required to insure that the proper replacement parts are obtained when required. If you have any questions concerning parts, service, or technical data, contact your nearest John Deere/Frontier dealer.

For complete warranty information refer to the warranty in the Owner's Information section of this manual.

---

# REPLACEMENT PARTS

---

**WE RECOMMEND JOHN DEERE/FRONTIER** quality parts and lubricants available at your John Deere/Frontier dealer.

**PART NUMBERS MAY CHANGE.** When you order replacement parts, use the part numbers listed below and on the following pages. If a part number changes, your John Deere/Frontier dealer will have the latest part number.

**WHEN YOU ORDER PARTS,** your John Deere/Frontier dealer must have your snowthrower model and serial number and your engine model number. This is the model and serial number that you recorded in the “Owner’s Information” section of this Owner’s Manual.

## QUICK REFERENCE PART NUMBERS

The following is a list of replacement parts that you may need for routine service and maintenance. If you do not see the replacement part you need in the following chart, then check the full list of replacement part illustrations following this page.

ITEM	PART NUMBER *
Belt, Drive	MT579932
Belt, Auger	MT585416
Scraper Blade	MT583043E701
Spark Plug	Champion RC12YC

\* **Part Numbers are subject to change without notice.**

# FRONTIER MODEL ST1028

# FACTORY MODEL 628104x16A ENGINE

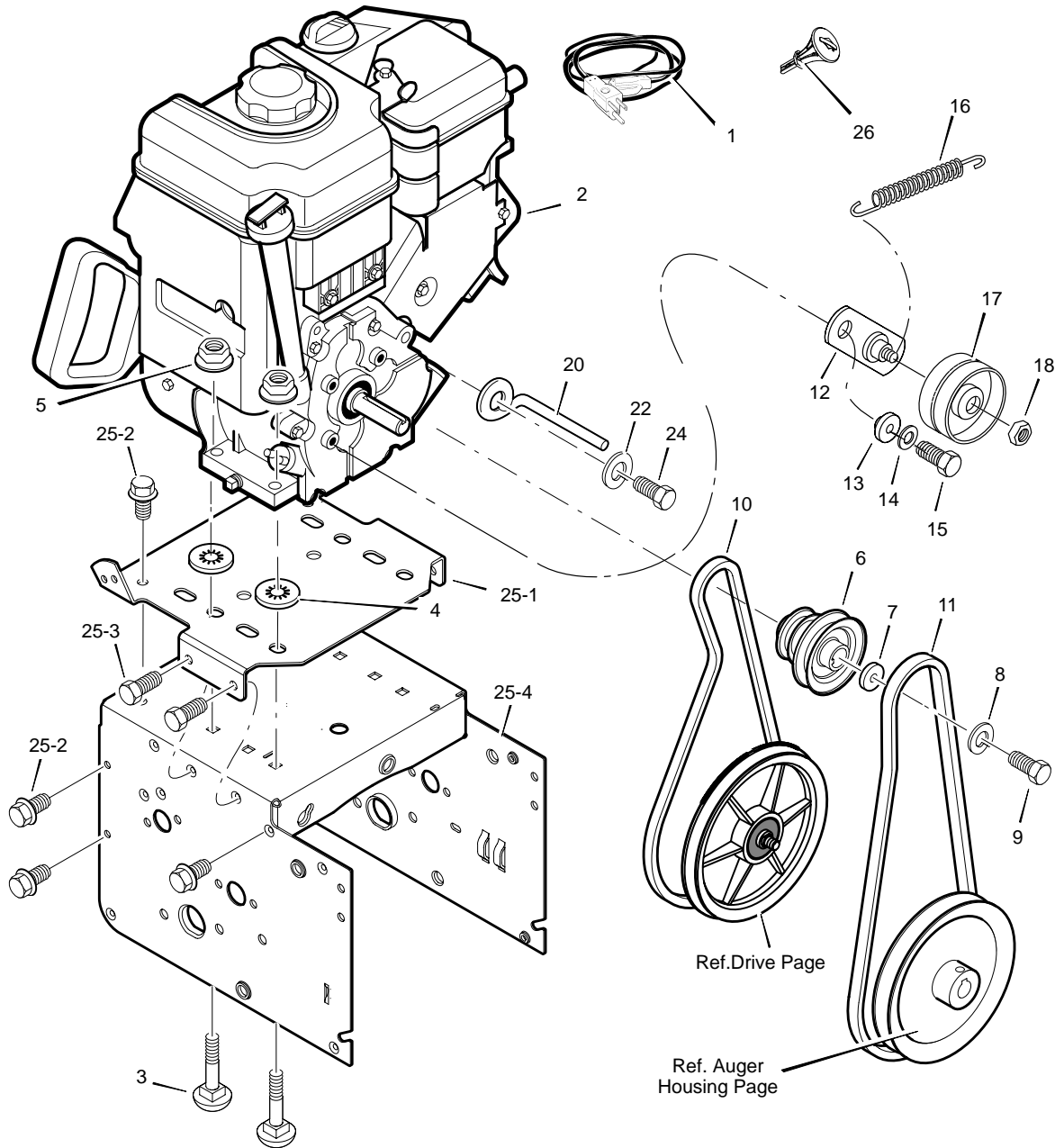

Key No.	Part No.	Description
1	MT6219	CORD, STARTER
2	- - - - -	ENGINE
3	MT002x97	BOLT, CARRIAGE
4	MT028x76	RETAINER, PUSH
5	MT710026	NUT
6	MT1501109	PULLEY, ENGINE
7	MT710247	WASHER
8	MT71063	WASHER
9	MT71015	SCREW
10	MT579932	BELT, DRIVE V 3L
11	MT585416	BELT, AUGER V 4L
12	MT1501112 YZ	BRACKET ASSEMBLY, IDLER
13	MT1501065	BUSHING, IDLER BRACKET
14	MT71060	WASHER, SPLIT

Key No.	Part No.	Description
15	MT910828	SCREW 5/16-24 X 1.00
16	MT165x164	SPRING, IDLER TRACTION DRIVE
17	MT50793	PULLEY, IDLER
18	MT590	NUT, JAM 3/8-16
20	MT1501201	GUIDE, ROD BELT
22	MT71060	WASHER
24	MT710097	SCREW
25	- - - - -	FRAME ASSEMBLY
25-1	MT1501062E511	PLATE, ENGINE
25-2	MT310169	SCREW
25-3	MT25x020	SCREW
25-4	MT1501049E511	MOTOR BOX
26	MT1501214	KEY, BRIGGS ENGINE
--	MTF-031042L	OWNER'S MANUAL

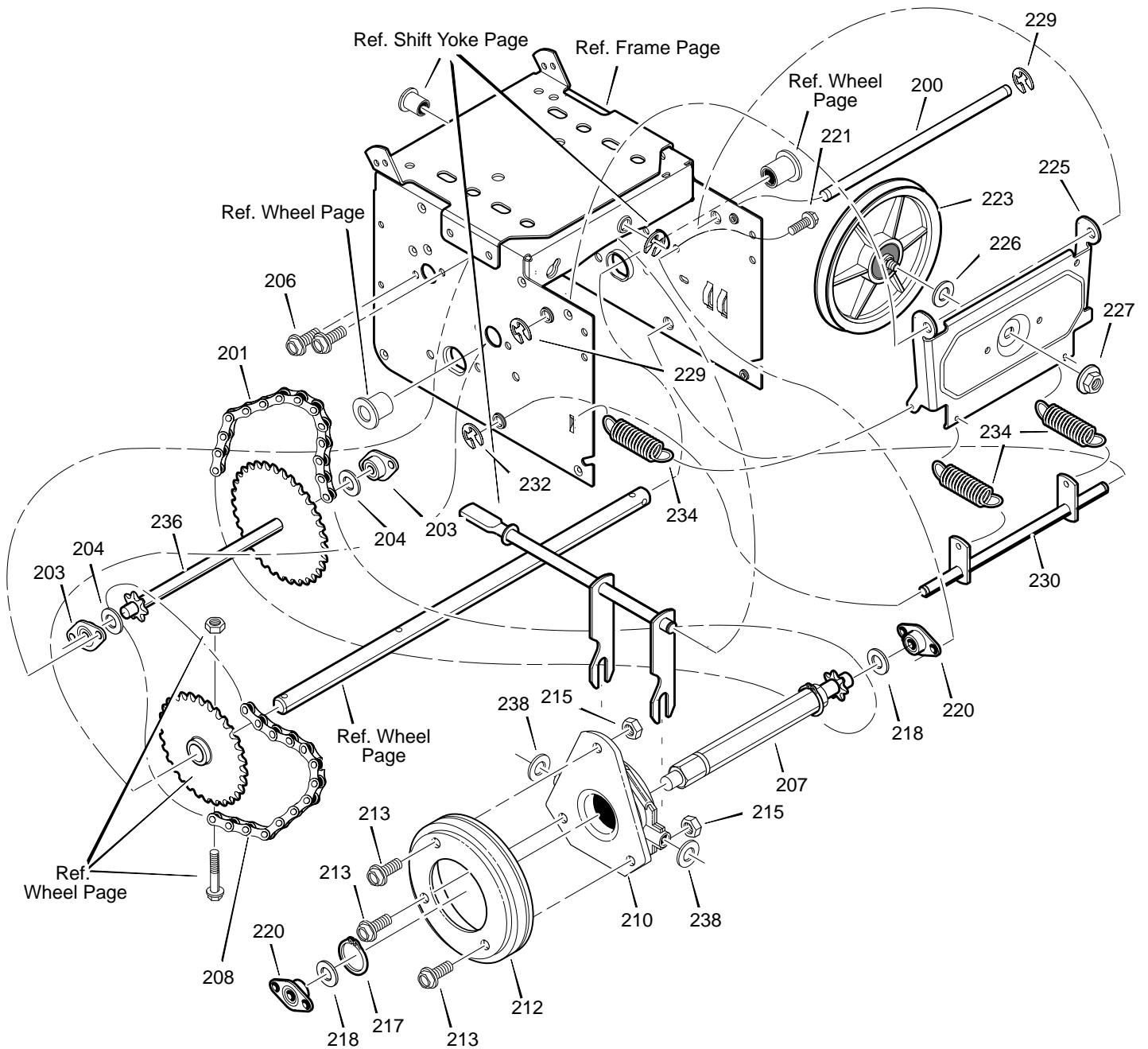

# FRONTIER MODEL ST1028

# FACTORY MODEL 628104x16A DRIVE

Key No.	Part No.	Description
200	MT1501092 YZ	LF AXLE, SWING PLATE YZ
201	MT579851	CHAIN, ROLLER #420x19.00
203	MT334163	BEARING AND RETAINER, ASSY
204	MT579858	WASHER
206	MT780055	SCREW, TAP 5/16-18x0.5
207	MT1501100	ASSY, HEX SHAFT
208	MT579868	CHAIN, ROLLER #420x18.00 LG
210	MT337029	BEARING, TRUNION CLUTCH R
212	MT1501435	WHEEL, FRICTION DISC
213	MT001x38	BOLT
215	MT303008	NUT, KEPS HEX 1/4-20
217	MT579859	RING, RETEXT
218	MT579858	WASHER
220	MT334163	BEARING AND RETAINER, ASSY
221	MT780055	SCREW, TAP 5/16-18 x .5
223	MT1501115	FRICTION PULLY
225	MT1501057 YZ	LF PLATE, SWINGING YZ
226	MT1501158	SPACER, FRICTION PULLEY
227	MT15X114	NUT, FLANGE LOCK 3/8-24
229	MT11X30	RETAINER, RING
230	MT1501107 YZ	LF ASSY, SPRING LINK YZ
232	MT11X30	RETAINER, RING
234	MT165X112	SPRING, EXTENSION
236	MT1501090	SPROCKET 33/7
238	MT71074	WASHER, FLAT

# FRONTIER MODEL ST1028

# FACTORY MODEL 628104x16A AUGER HOUSING

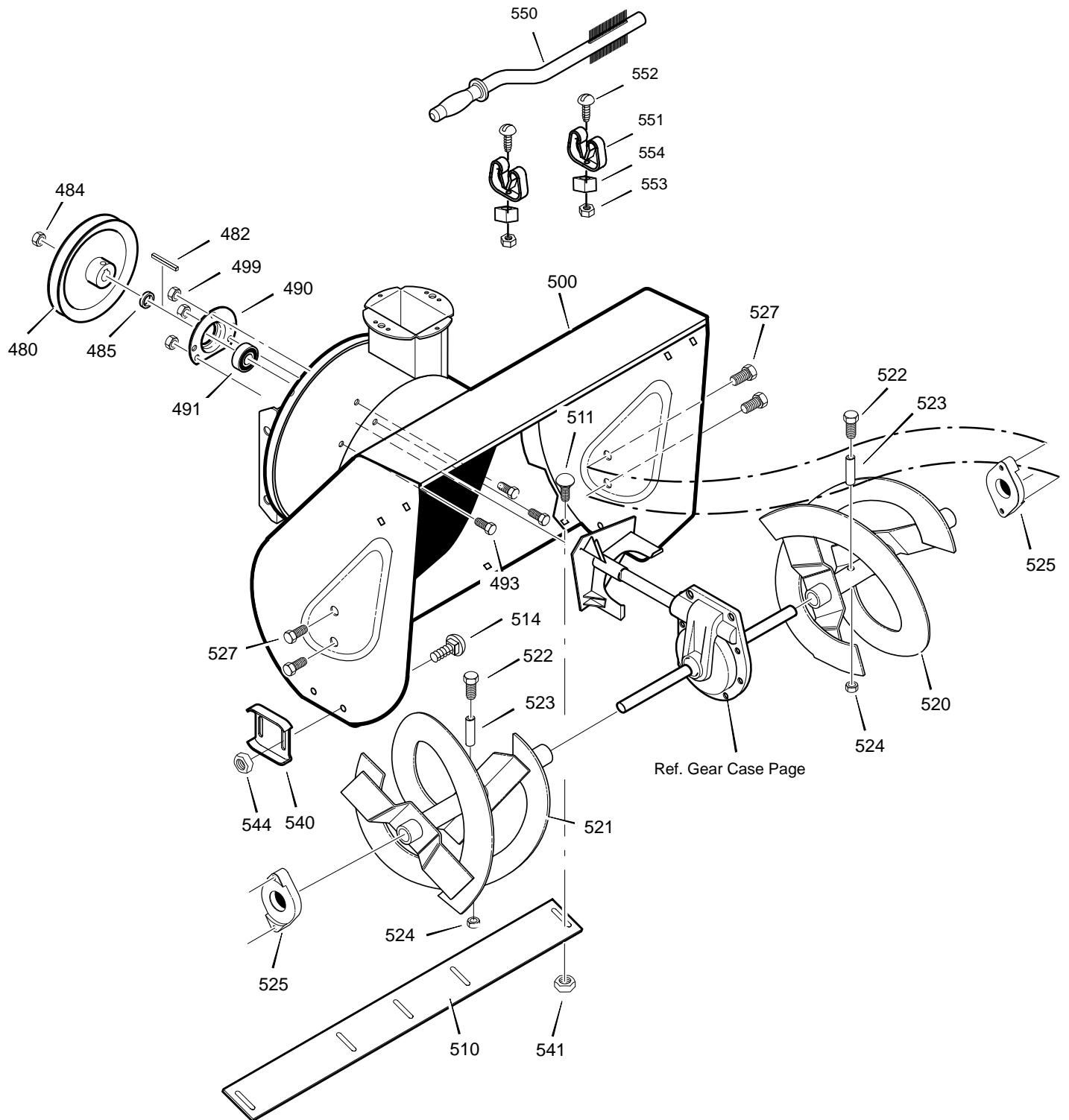



# FRONTIER MODEL ST1028

# FACTORY MODEL 628104x16A AUGER HOUSING

Key No.	Part No.	Description
480	MT583146	PULLEY, 4L 8.40 OD
482	MT2001022	KEY, SQUARE 3/16 X 3/4
484	MT15x112	NUT, 1/2-20
485	MT1501158	SPACER, FRICTION PULLEY
490	MT582957 YZ	RETAINER, BALL BRNG
491	MT43846	BEARING, BALL
493	MT001X92	BOLT, HEX 5/16-18X .50
499	MT710026	NUT, 5/16-18 HEXWDFLLK
500	MT1501590E511	HOUSING, ASSY
510	MT583043E701	BLADE, SCRAPER
511	MT340720	BOLT, 5/16-18X.75
514	MT710026	NUT, 5/16-18
520	MT760597E701	AUGER, ASSY, LH
521	MT760598E701	AUGER, ASSY, RH
522	MT9524	SCREW, 1/4-20 X 1.75
523	MT3943	SPACER, SLEEVE
524	MT73826	NUT, 1/4-20
525	MT53757	BEARING, FLANGE
527	MT70984	SCREW, 5/16-18X .75
540	MT762377E701	SKID, HEIGHT ADJUST
541	MT340720	BOLT, 5/16-18 X .75
544	MT710026	NUT, 5/16-18
550	MT1501576	BRUSH, CLEANOUT
551	MT1501672	CLIP, RETAINER
552	MT06x115	SCREW
553	MT15x146	NUT
554	MT578063	BLOCK
- -	MT1501216	KIT, SHEAR BOLT

# FRONTIER MODEL ST1028

# FACTORY MODEL 628104x16A GEAR CASE

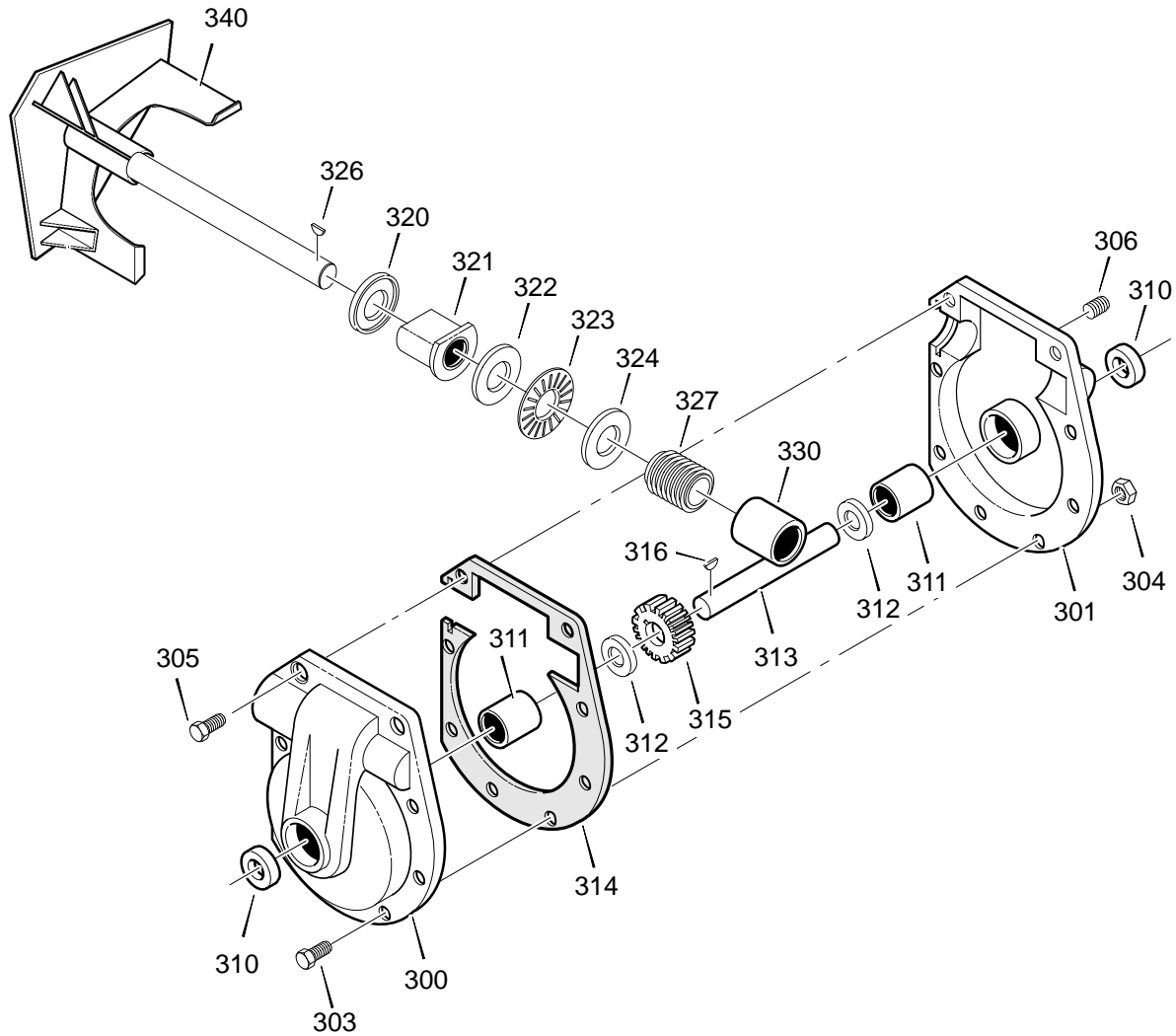

Key No.	Part No.	Description	Key No.	Part No.	Description
300	MT896	CASE, GEAR, RH	316	MT73905	KEY, WOODRUFF #91
301	MT895	CASE, GEAR, LH	320	MT53737	RING, QUAD 0.924 ID
303	MT910828	SCREW, 5/16-24 x 1.00	321	MT583126	BEARING, FLANGE
304	MT71100	NUT, 5/16-24	322	MT48275	WASHER, FLAT
305	MT330434	SCREW, 5/16-24 x 1.50	323	MT50684	BEARING, ROLLER
306	MT53749	PLUG, PIPE 0.25-18	324	MT48275	WASHER, FLAT
310	MT780151	SEAL, OIL	326	MT50795	KEY
311	MT53743	BEARING, SLEEVE	327	MT53732	WORM
312	MT53748	WASHER, FLAT	330	MT53731	BEARING, SLEEVE
313	MT760528	SHAFT, AUGER OUTPUT	340	MT1501147E701	IMPELLER
314	MT897	GASKET, GEAR BOX	--	MT333431	10oz TUBE LUBRIPLATE
315	MT53730	WORM GEAR			

# FRONTIER MODEL ST1028

# FACTORY MODEL 628104x16A REMOTE CONTROL

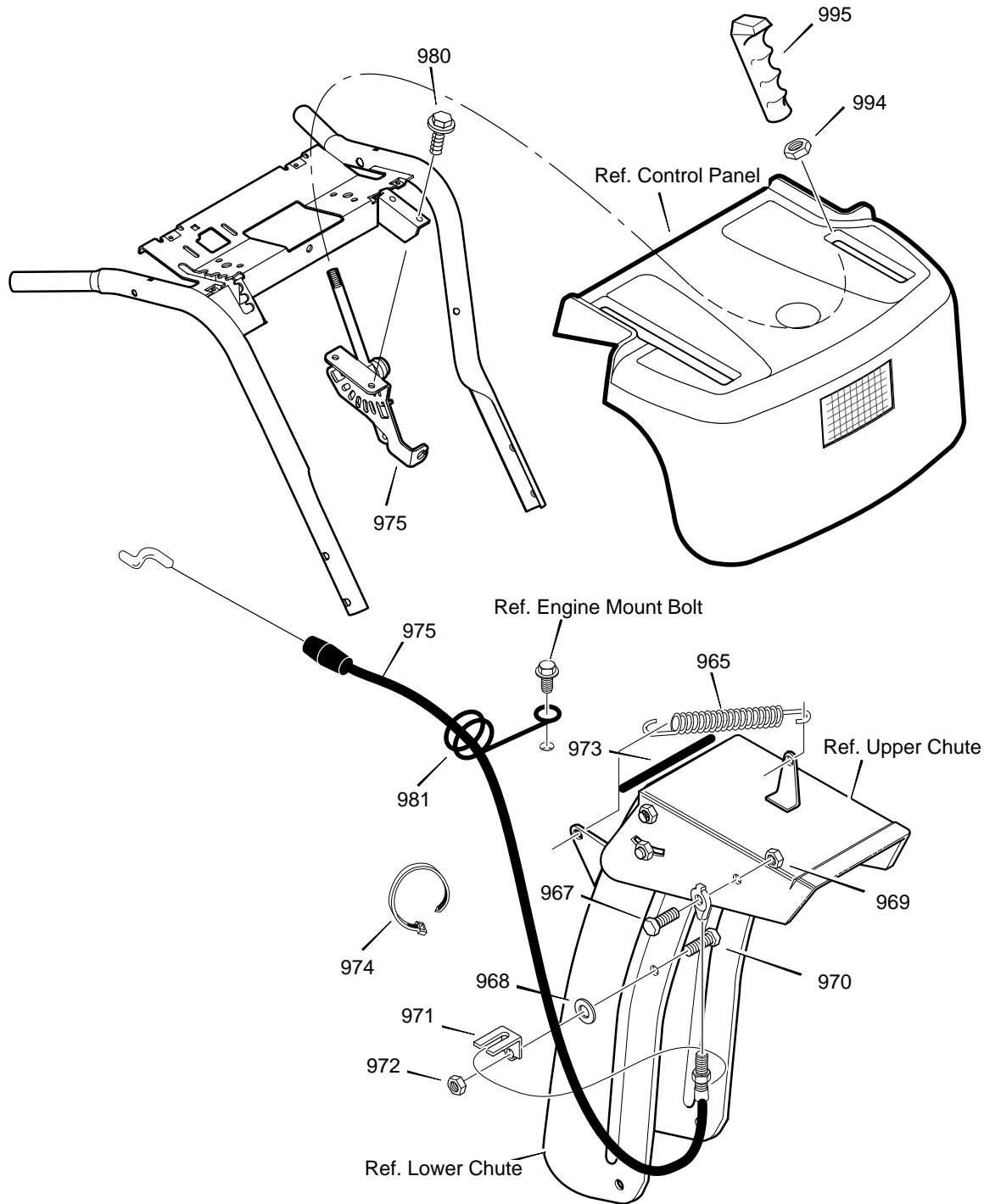

Key No.	Part No.	Description
965	MT318468	TENSION SPRING
967	MT310088	BOLT, SHOULDER
968	MT73787	FLATWASHER
969	MT15x143	NUT
970	MT313676	SCREW, 5/16-18 X 0.75
971	MT306447 YZ	BRACKET, CABLE CHUTE
972	MT71391	NUT, 5/16-18

Key No.	Part No.	Description
973	MT1001221	TRIM STRIP, BLACK
974	MT071372	TIE, CABLE
975	MT1501393	CABLE, CHUTE DEFLECTOR
980	MT313676	SCREW
981	MT780220	WIRE FORM, CHUTE CABLE
994	MT71045	NUT, 3/8-16
995	MT306689	KNOB, SHIFT

# FRONTIER MODEL ST1028

# FACTORY MODEL 628104x16A DISCHARGE CHUTE

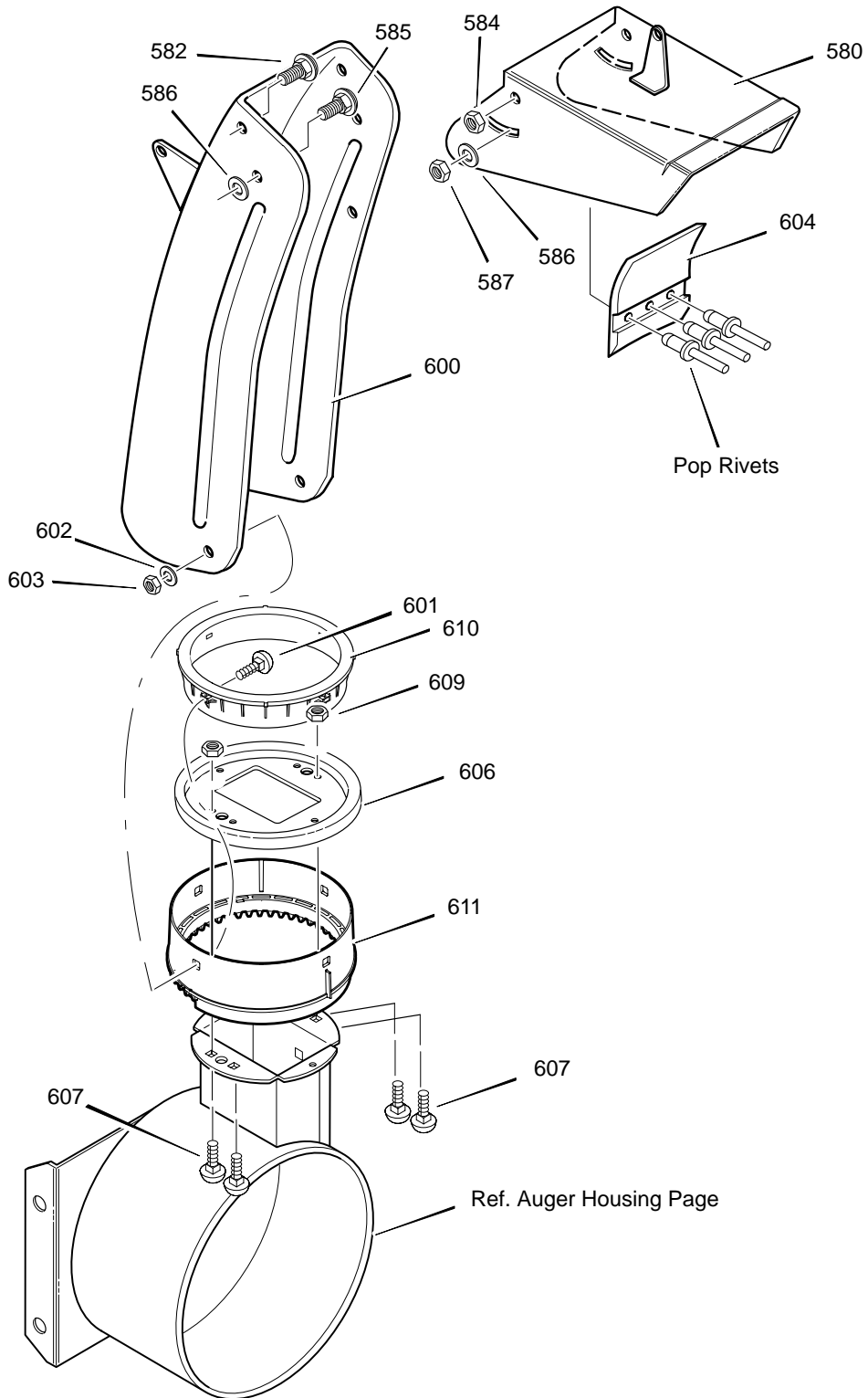

# FRONTIER MODEL ST1028

# FACTORY MODEL 628104x16A DISCHARGE CHUTE

<b>Key No.</b>	<b>Part No.</b>	<b>Description</b>
580	MT761168E701	CHUTE, UPPER W/REMOTE
582	MT578088	SCREW, 5/16-18 X.75
584	MT71038	NUT
585	MT578088	SCREW, 5/16-18 X.75
586	MT6711	PLASTIC WASHER
587	MT71038	NUT
600	MT761169E701	CHUTE, LOWER W/REMOTE
601	MT2x100	BOLT
602	MT71071	WASHER, FLAT
603	MT71038	NUT
604	MT762322	FLAP
606	MT585214 YZ	CHUTE COLLAR
607	MT02x101	BOLT
609	MT15x145	NUT
610	MT337227	RETAINER, RING INNER
611	MT1501282	RETAINER, RING OUTER

# FRONTIER MODEL ST1028

# FACTORY MODEL 628104x16A HANDLE

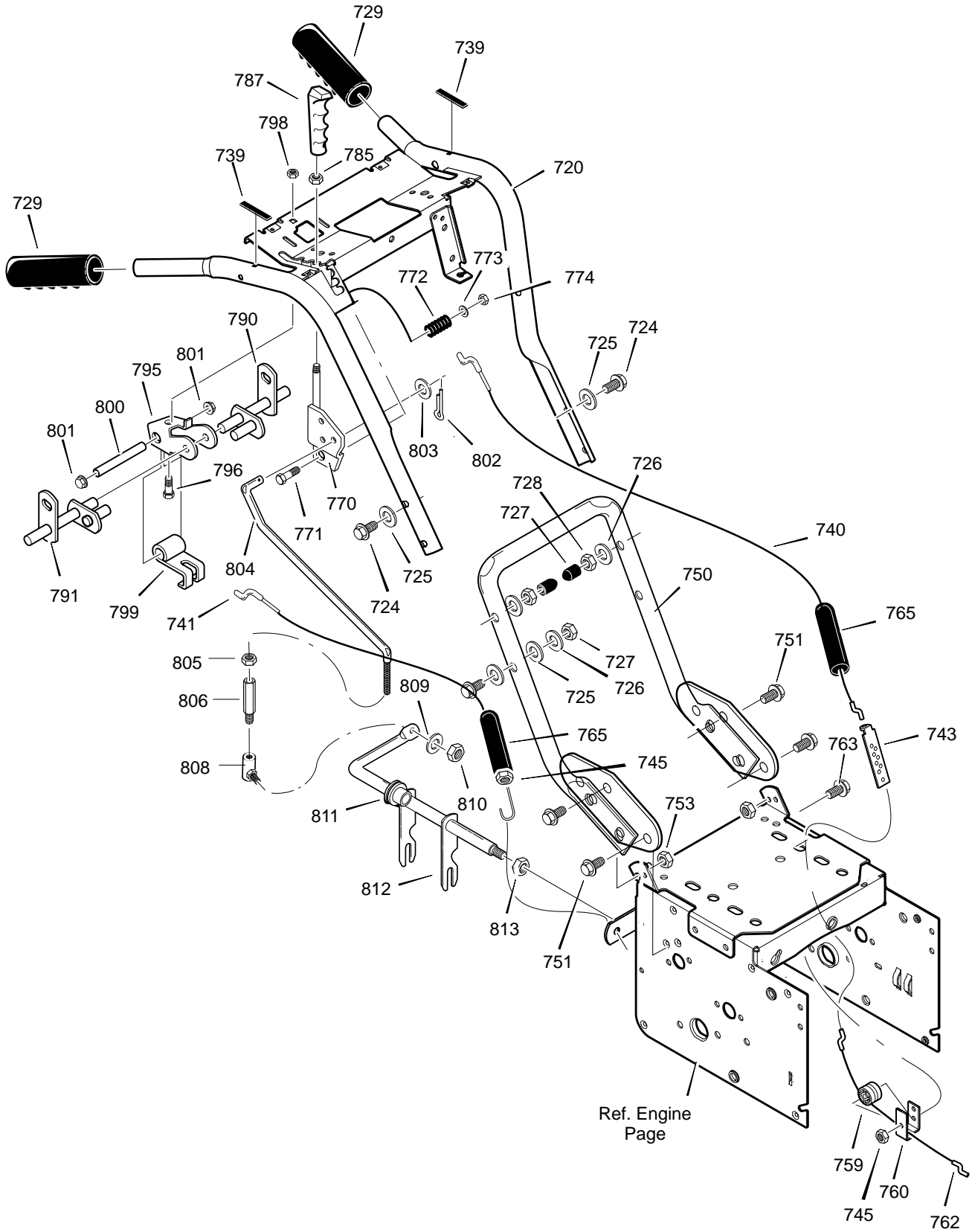

# FRONTIER MODEL ST1028

# FACTORY MODEL 628104x16A HANDLE

Key No.	Part No.	Description	Key No.	Part No.	Description
720	MT1501378E701	ASSY, HANDLE	773	MT71072	WASHER, FLAT
724	MT7288	SCREW	774	MT71046	NUT, HEX
725	MT71072	WASHER, FLAT	785	MT71045	NUT, HEX
726	MT71062	WASHER	787	MT306689	KNOB, SHIFT
727	MT71044	NUT	790	MT578926	ROD, ASSY LH
728	MT7289	STOP, PLASTIC	791	MT578924	ROD, ASSY RH
729	MT337399	GRIP, HANDLE	795	MT579002	BRACKET, CAM
739	MT4049	BUMPER	796	MT002x53	SCREW
740	MT1501451	CABLE, AUGER CLUTCH	798	MT71038	NUT, NYLOCK
741	MT1501452	CABLE, DRIVE	799	MT8417	CAM LOCK
743	MT313441	BRKT, CABLE ADJ	800	MT584673	PIN, SPRING PIVOT
744	MT1673	SPRING, CLUTCH	801	MT73664	NUT, PUSH ON
745	MT15x145	NUT, HEX	802	MT71081	PIN, COTTER
750	MT1501449E701	HANDLE, LOWER	803	MT71071	FLATWASHER
751	MT25x021	SCREW	804	MT1501642	ROD, SPEED CONTROL
758	MT15x144	BOLT, HEX	805	MT71042	NUT, 5/16-18
759	MT579860	SPOOL, CABLE	806	MT6352	ADAPTER, ROD
760	MT1501059 YZ	BRKT, SPOOL	808	MT50782	BALLJOINT, STEEL
762	MT1501122	CABLE, LOWER DRIVE	809	MT71060	WASHER
763	MT001798	BOLT, HEX 1/4-20 x 1.5	810	MT71042	NUT, 5/16-18
765	MT308146	BOOT, CABLE	811	MT579944	BEARING, FL
770	MT1501570 YZ	BRACKET, SHIFT	812	MT1501110 YZ	ROD, YOKE
771	MT4058	SCREW	813	MT11X30	RETAINER, RING
772	MT50786	SPRING			

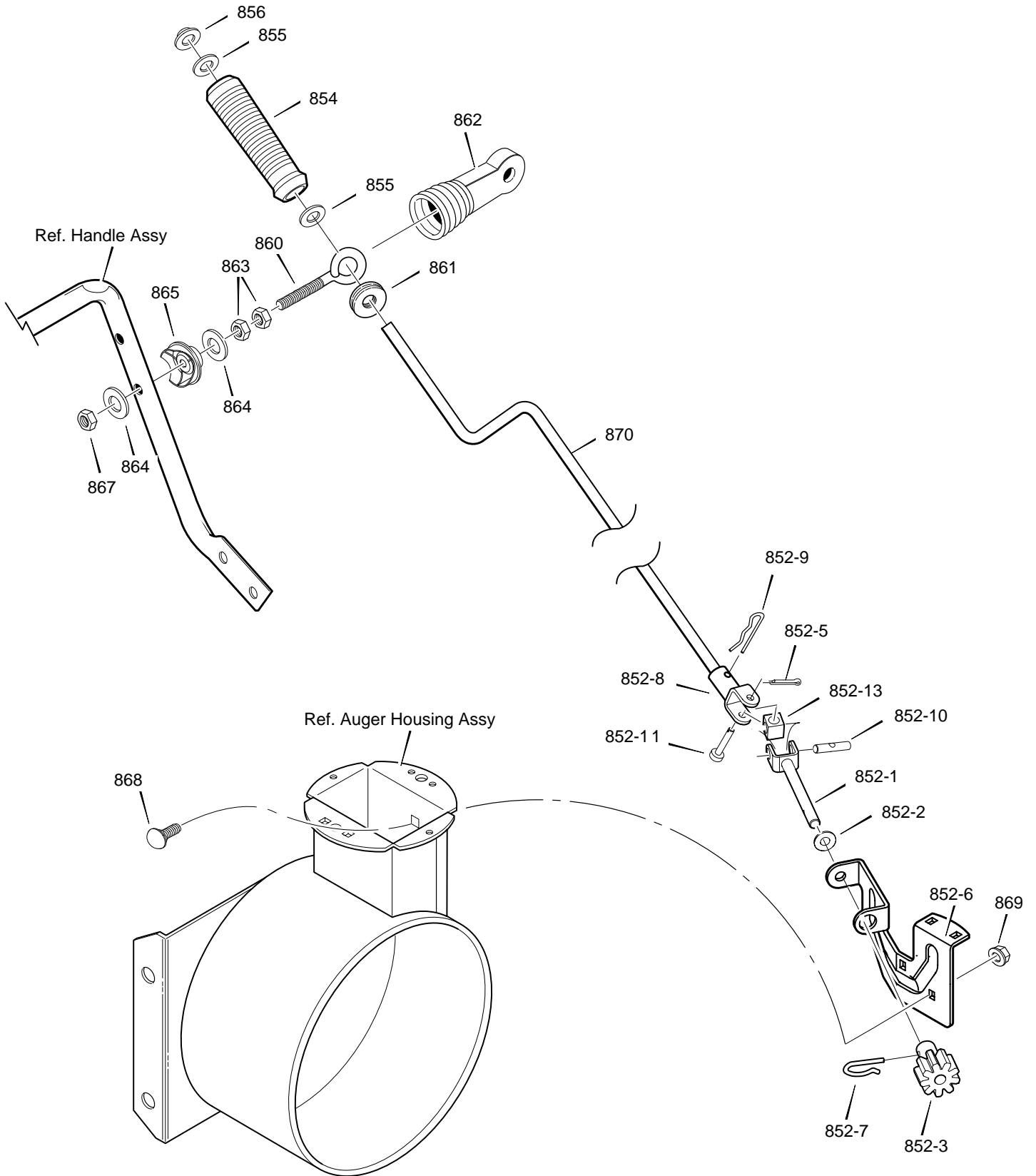



# FRONTIER MODEL ST1028

# FACTORY MODEL 628104x16A CHUTE ROD

<b>Key No.</b>	<b>Part No.</b>	<b>Description</b>
852-1	MT1501309 YZ	ASSEMBLY, YOKE & ROD
852-2	MT313431	WASHER, CURVED SPRING
852-3	MT1501067	GEAR, CHUTE ROTATION 9T
852-5	MT579493	PIN, COTTER
852-6	MT1501306E701	BRACKET, GEAR MOUNT
852-7	MT1501293	PIN, HAIR
852-8	MT1501075 YZ	ASSEMBLY, YOKE ADAPTER YZ
852-9	MT711682	PIN, HAIR
852-10	MT578060	PIN, UNIVERSAL JOINT
852-11	MT578309	PIN, CLEVIS
852-13	MT578063	HOUSING, UNIVERSAL
854	MT307399	KNOB, SLEEVE
855	MT309312	FLATWASHER
856	MT73664	NUT, PUSH ON 3/8"
860	MT581618	EYE BOLT 3/8-16X6.00
861	MT148	GROMMET, EYE BOLT
862	MT308145	BOOT, EYE BOLT
863	MT71045	NUT, 3/8-16 HEXJAM
864	MT71072	FLATWASHER .406X.81X.066
865	MT309344	ADAPTER, BOOT
867	MT71046	NUT, 3/8-16 HEXNYL
868	MT002X98	BOLT, CARRIAGE 1/4-20 X 1.00
869	MT15x145	NUT, 1/4-20
870	MT1501074 YZ	CRANK, ASSY CHUTE

# FRONTIER MODEL ST1028

# FACTORY MODEL 628104x16A CONTROL PANEL

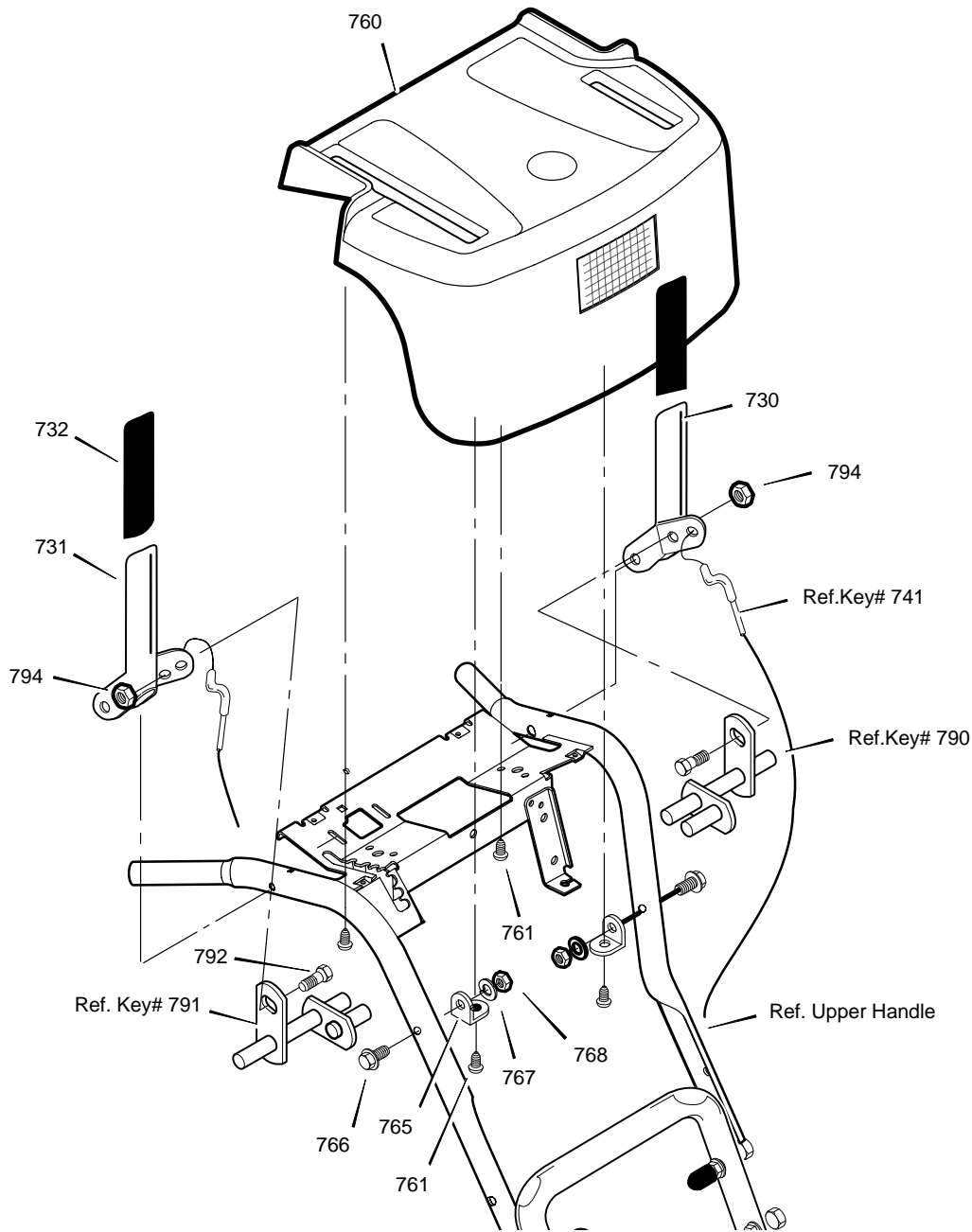

Key No.	Part No.	Description
730	MT1501358E701	CLUTCH HANDLE LH
731	MT1501357E701	CLUTCH HANDLE RH
732	MT337380	GRIP, CLUTCH LEVER
760	MT1501415	PANEL, CONTROL
761	MT316042	SCREW
765	MT578866E701	BRACKET, PANEL
766	MT302900	SCREW, 5/16-18 X 1.75
767	MT71060	WASHER
768	MT15x144	NUT, 5/16-18
792	MT905531	BOLT, 1/4-20 X 0.50
794	MT908913	NUT, 1/4-20

# FRONTIER MODEL ST1028

# FACTORY MODEL 628104x16A HEADLIGHT

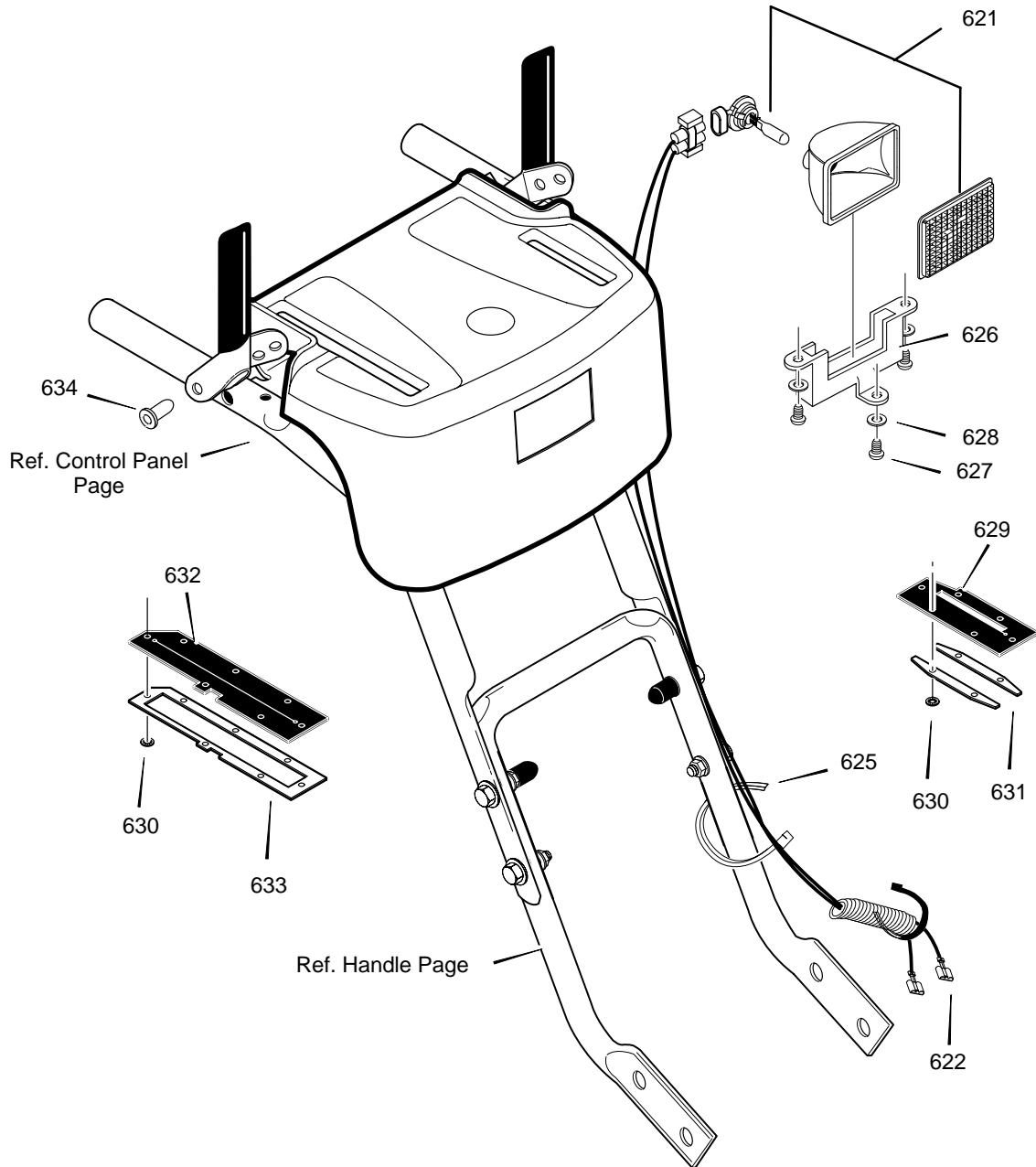

Key No.	Part No.	Description
621	MT762343	LIGHT, HALOGEN
622	MT1501455	HARNESS, WIRE
625	MT071372	TIE, CABLE
626	MT1501412	BRACKET, LIGHT
627	MT901696	SCREW #8 X .50
628	MT901736	WASHER, FLAT
629	MT1501543	COVER, CHUTE LEVER
630	MT028x79	NUT, PUSH
631	MT1501545	FRAME, COVER
632	MT1501542	COVER, SPEED LEVER
633	MT1501544	FRAME, SPEED COVER
634	MT760987	RIVET, 0.125 x 0.23

# FRONTIER MODEL ST1028

# FACTORY MODEL 628104x16A WHEELS

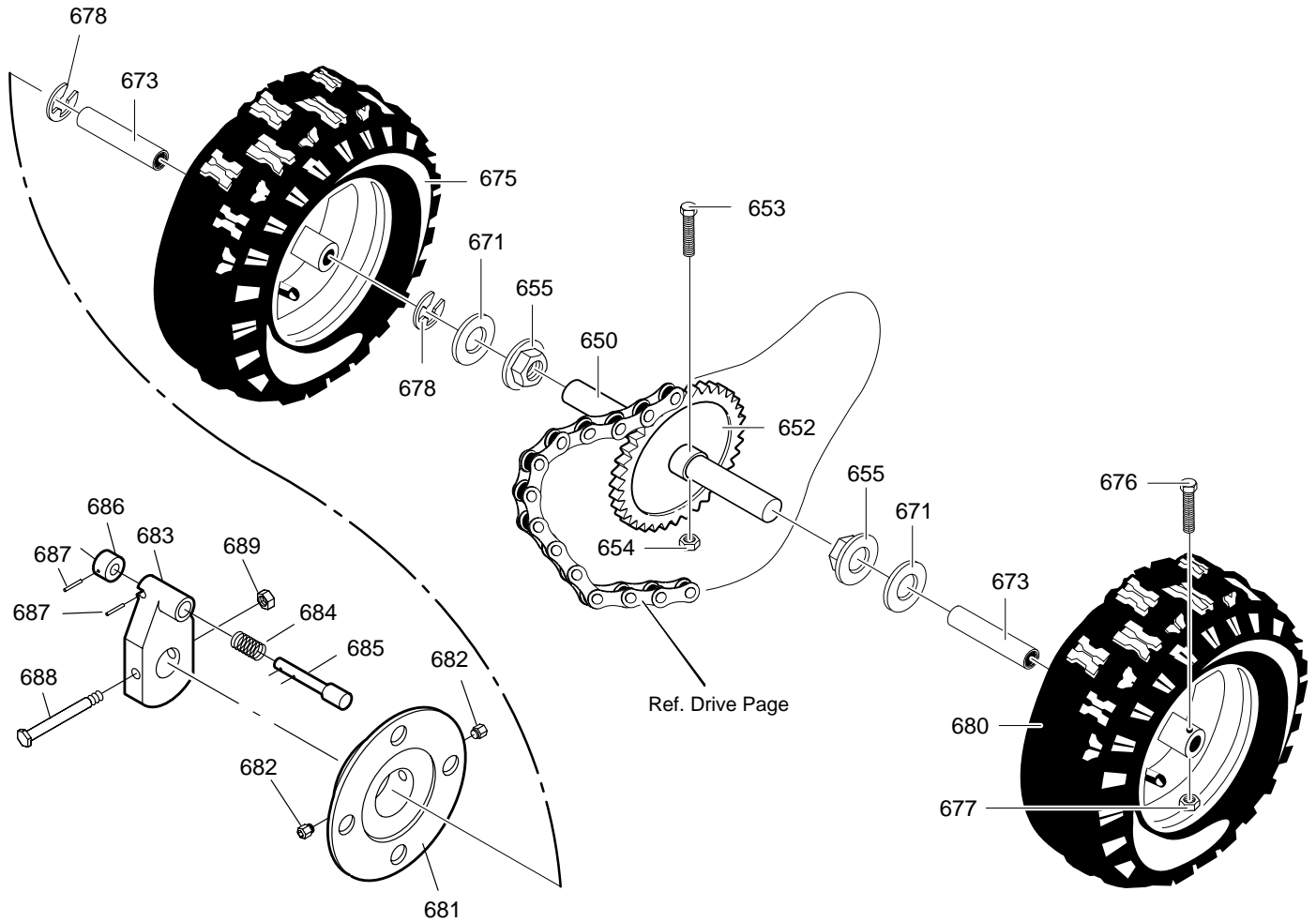

Key No.	Part No.	Description	Key No.	Part No.	Description
650	MT1501563 YZ	SHAFT, AXLE	680	MT1501657	TIRE & RIM, LEFT
652	MT1501089	SPRKT & HUB	681	MT1501032E701	DISC, WHEEL
653	MT01x193	SCREW, 1/4-20X1.75	682	MT2001066	SCREW
654	MT15x145	NUT, 1/4-20 HEX NYLOCK	683	MT1501546	HUB, WHEEL LOCK
655	MT1501114	BEARING, AXLE	684	MT164X34	SPRING, COMPRESSION
671	MT712120	FLATWASHER	685	MT1501033 YZ	PIN, LOCK
673	MT1501138	BUSHING, WHEEL	686	MT1501034	KNOB
675	MT1501657	TIRE & RIM, RIGHT	687	MT032X79	PIN
676	MT577015	SCREW, 1/4-20X1.75	688	MT73839	SCREW
677	MT15x145	NUT, 1/4-20 HEX NYLOCK	689	MT15x116	NUT
678	MT239	RING, RET			

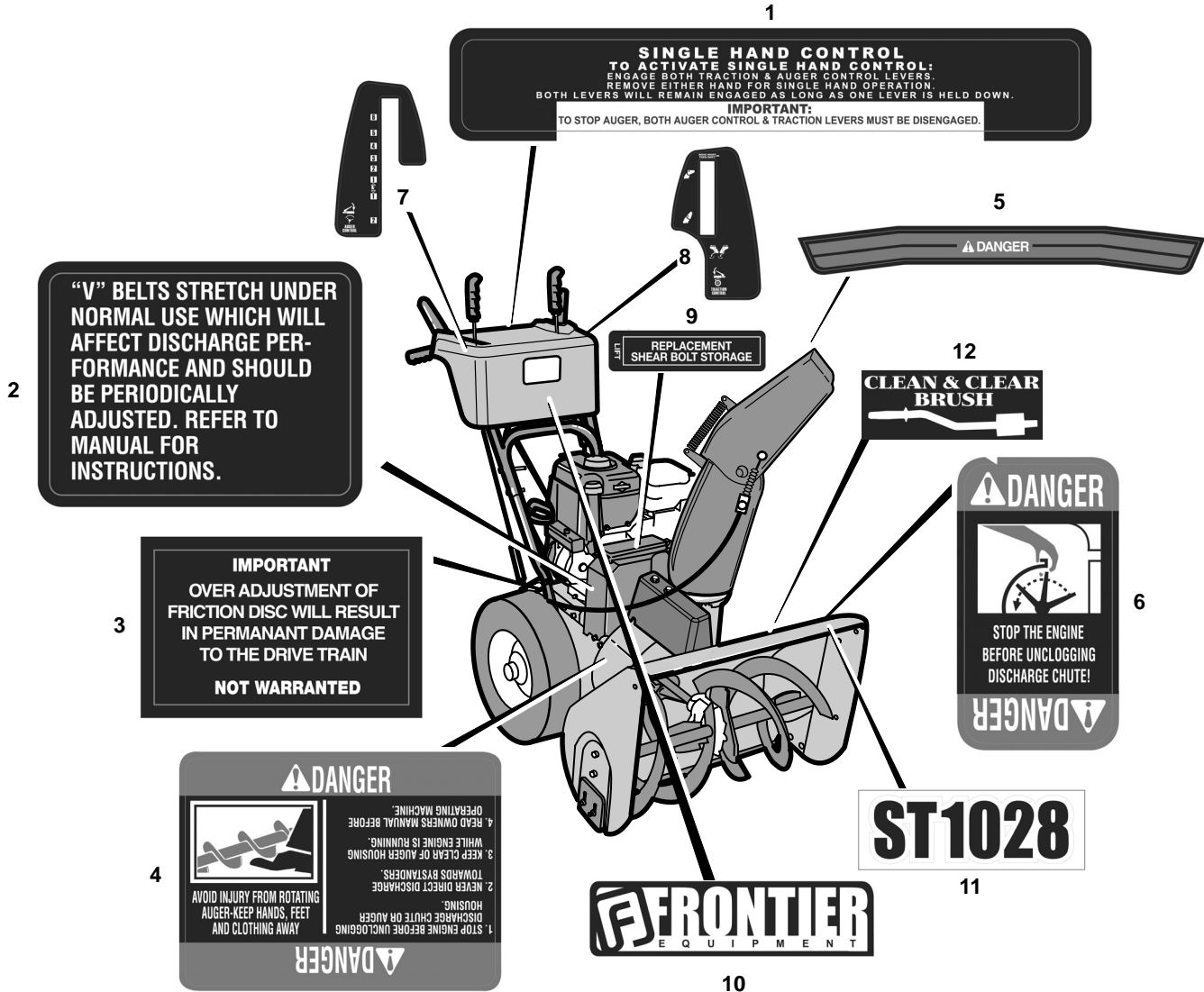

Key No.	Part No.	Description
1	MT48x5294	DECAL, SINGLE HAND CONTROL
2	MT7390	DECAL, V-BELTS
3	MT7859	DECAL, OVER ADJUSTMENT
4	MT48x5286	DECAL, ROTATING AUGER
5	MT761078	DECAL, DANGER
6	MT48x5285	DECAL, UNCLOGGING CHUTE
7	MT48x5291	DECAL, SPEED CONTROL
8	MT48x5292	DECAL, REMOTE CHUTE CONTROL
9	MT760983	DECAL, SHEAR BOLTS
10	MT1501548	LOGO NAMEPLATE, FRONTIER
11	MT48x5296	DECAL, ST1028
12	MT48x5254	DECAL, CLEAN & CLEAR BRUSH
--	MTF-031042L	OPERATOR'S MANUAL

# FRONTIER MODEL ST1028

# FACTORY MODEL 628104x16A FRAME

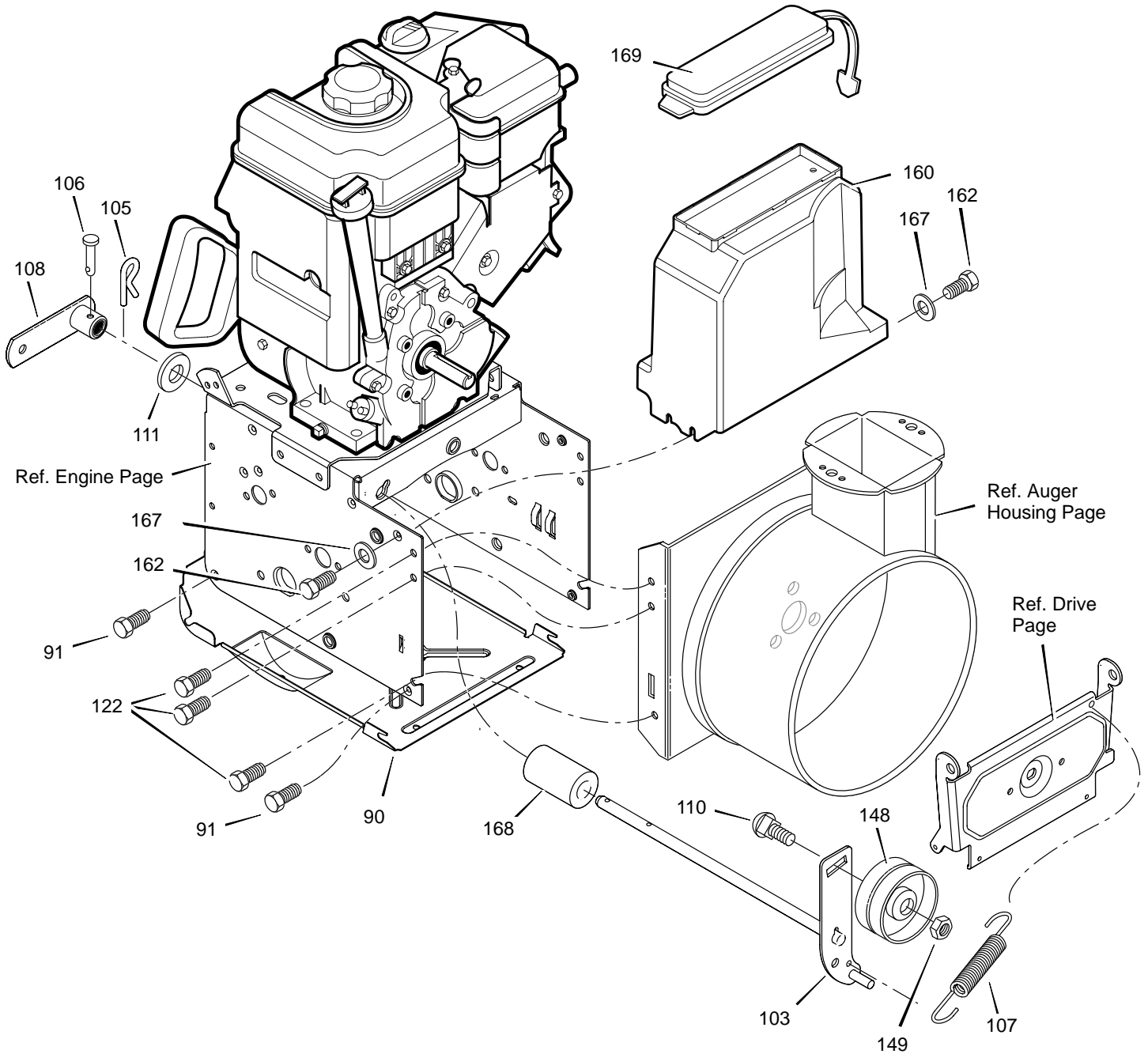

# FRONTIER MODEL ST1028

# FACTORY MODEL 628104x16A FRAME

<b>Key No.</b>	<b>Part No.</b>	<b>Description</b>
90	MT1501055E701	COVER, BOTTOM
91	MT310169	SCREW, 1/4-20X .63
103	MT1501226 YZ	IDLER ASSEMBLY, AUGER
105	MT711682	PIN, HAIR .38DIAx1.64LG
106	MT761761	PIN, CLEVIS 3/16" DIA
107	MT165x159	SPRING, TENSION
108	MT761675 YZ	ASSY., SPRING ATTACH
110	MT585781	BOLT, 3/8-16X1.25 CARR.
111	MT711617	WASHER, FLAT
122	MT780055	SCREW, TAP 5/16-18 X .50
148	MT50793	PULLEY, IDLER
149	MT590	NUT, JAM 3/8-16
160	MT1501052	COVER, BELT
162	MT26x306	SCREW, TAP
167	MT71067	WASHER, FLAT
168	MT1501200	SPACER, AUGER BRACKET
169	MT760539	LID, TOOL BOX

# SPECIFICATIONS ST1028

<b>Engine</b>	Briggs & Stratton Intek Snow OHV
<b>Horsepower</b>	10 hp
<b>Starter</b>	Electric / Recoil
<b>Fuel Capacity</b>	4 quarts
<b>Drive System</b>	Friction Disc
<b>Speeds</b>	6 Forward / 2 Reverse
<b>Tire Diameter</b>	16"
<b>Traction Control</b>	Wheel Lock
<b>Clearing Width</b>	28"
<b>Housing Height</b>	21"
<b>Auger Diameter</b>	12"
<b>Auger Type</b>	Steel / Saw Tooth
<b>Impeller Diameter</b>	12"
<b>Chute Rotation</b>	Remote
<b>Chute Turning Radius</b>	190°
<b>Deflector Control</b>	Remote
<b>Weight</b>	271 lbs
<b>Warranty - Engine</b>	3 years
<b>Warranty - Machine</b>	3 years

