

ST1028 Snow Thrower

OPERATOR'S MANUAL

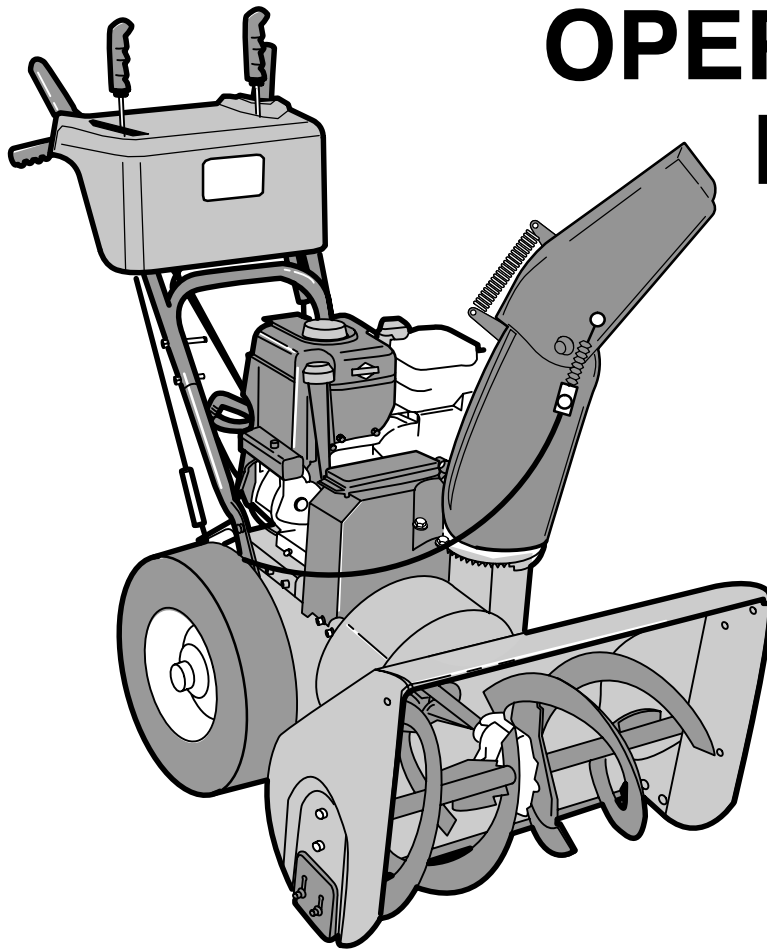

MTF-051058L

F FRONTIER
EQUIPMENT™

INTRODUCTION

Congratulations on your purchase of a Frontier Snowthrower. It has been designed, engineered and manufactured to give you the best possible dependability and performance. However, like all mechanical products, your machine will occasionally require adjustment and maintenance. This handbook should be read before operating or performing adjustments on your machine.

The instructions in this Owner's Manual are written for a person with some mechanical ability. Like most service books, not all the steps are described. Steps on how to loosen or tighten fasteners are steps anyone can follow with some mechanical ability. Read and follow these instructions before you use the unit.

Know your product:: If you understand the unit and how the unit operates, you will get the best performance. As you read this manual, compare the illustrations to the unit. Learn the location and the function of the controls. To help prevent an accident, follow the operating instructions and the safety rules. Keep this manual for future reference.

IMPORTANT: Many units are not assembled and are sold in cartons. It is the responsibility of the owner to make sure the assembly instructions in this manual are exactly followed. Other units are purchased in an assembled condition. On assembled units, it is the responsibility of the owner to make sure the unit is correctly assembled. The owner must carefully check the unit according to the instructions in this manual before it is first used.

The warranty, found in this manual, details the coverage and limitations of this product. **Registration of the warranty is necessary and must be preformed by the dealer within sixty (60) days from the date of retail sale or delivery.** The Warranty Registration Form is located on the Frontier website.

RESPONSIBILITY OF THE OWNER

The responsibility of the owners to follow the instructions below.

1. Carefully read and follow the rules for safe operation.
2. Follow all the assembly instructions.
3. Inspect the unit.
4. Make sure that the operator of the unit knows how to correctly use all standard and accessory equipment.
5. Operate the unit only with guards, shields, and other safety items in place and working correctly.
6. Correctly adjust the unit.
7. Service the unit only with authorized or approved replacement parts.
8. Complete all maintenance on the unit.



PRODUCT INFORMATION

The owner must be certain that all the product information is included with this unit.

This information includes the *INSTRUCTION BOOKS*, the *REPLACEMENT PARTS* and the *WARRANTIES*. This information must be included to make sure state laws and other laws are followed.

**Read And Keep This Book For
Future Reference. This Book Contains Important Information On:
*SAFETY, ASSEMBLY, OPERATION AND MAINTENANCE.***



RULES FOR SAFE OPERATION

  This manual contains safety information to make you aware of the hazards and risks associated with snow throwers, and how to avoid them. The snow thrower is designed and intended for removal of snow, and should not be used for any other purpose. It is important that you read and understand these instructions, and anyone operating the equipment read and understand these instructions.

WARNING



The engine exhaust from this product contains chemicals known to the State of California to cause cancer, birth defects, or other reproductive harm.

A signal word (DANGER, WARNING, or CAUTION) is used with the alert symbol to indicate the likelihood and the potential severity of injury. In addition, a hazard symbol may be used to represent the type of hazard.

-  **DANGER** indicates a hazard which, if not avoided, **will result in death or serious injury.**
-  **WARNING** indicates a hazard which, if not avoided, **could result in death or serious injury.**
-  **CAUTION** indicates a hazard which, if not avoided, **might result in minor or moderate injury.**
CAUTION, when used **without** the alert symbol, indicates a situation that **could result in damage to the equipment.**























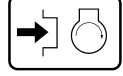









Hazard Symbols and the meanings

These symbols are used on your equipment and defined in your operating manual. Review and understand the meanings. The use of one of these symbols combined with a signal word will alert you to potential hazards and how to avoid them.

	Safety Alert – Identifies safety information about hazards that can result in personal injury.
	Operator's Manual – Read and understand before performing any activity or running equipment.
	Rotating auger
	Fire
	Rotating impeller
	Explosion
	Toxic fumes
	Shock
	Rotating gears
	Hot Surface
	Thrown objects
	Keep a safe distance from the equipment.

Operating Symbols and their meanings

These symbols are used on your equipment and defined in your operating manual. It is important that you review and understand the meanings. Failure to understand the symbols might result in harm to you.

	Oil		Forward
	Fuel		Neutral
	On Off		Reverse
	Primer bulb		Ignition On
	Throttle		Ignition Off
	Choke off		Ignition Key
	Choke on		Push to engage electric start
	Stop		Electric Start
	Slow		Engine Start
	Fast		Engine Run
	Engage		Engine Off
	Traction		Engage
	Auger Collector		Disengage
	Auger Clutch		Discharge Chute
	Drive Clutch		Chute Deflector
			LEFT
			RIGHT
			UP
			DOWN

RULES FOR SAFE OPERATION



DANGER

Avoid death or serious injury from rotating auger.
Keep hands, feet and clothing away.
Unclogging discharge chute is a hazardous activity.

- Never attempt to clear auger of debris or clogged snow while equipment is engaged or engine is running. Clogged or blocked augers store energy and can rotate unexpectedly, **EVEN WITH ENGINE OFF**.
- Stop engine and disconnect spark plug wire when performing maintenance on equipment.
- Never leave the equipment unattended while engine is running. Always disengage the auger and traction controls, stop engine, and remove keys.
- Keep children, pets, and others out of the area during operation. Children are often attracted to the equipment. Be mindful of all persons present.
- Keep all loose clothing far away from front of snow thrower and auger. Scarfs, mittens, dangling drawstrings, loose clothes and pants can quickly become caught in the rotating device and dismemberment will occur. Tie up long hair and remove jewelry.
- The snow thrower is intended to remove snow only. Do not use for other purposes other than what is intended.
- Do not clear snow across the face of slopes. Exercise extreme caution when changing direction on slopes. Do not attempt to clear steep slopes.
- Do not use the snow thrower on surfaces above ground level such as roofs of residences, garages, porches or other such structures or buildings.



DANGER

Objects can be picked up by auger and thrown from chute.
Never throw snow toward people or cars, and never allow anyone in front of the snow thrower.

- Be aware of your environment while operating equipment. Running over items such as, gravel, doormats, newspapers, toys, and rocks hidden under snow, can all be thrown from chute or jam in the auger.
- Always be aware of the direction the snow is being thrown. Nearby pedestrians, pets or property may be harmed by objects being thrown.
- Familiarize yourself with the area you plan to work. Mark off boundaries of walkways and driveways to prevent property damage, or throwing objects.
- Take caution when snow throwing in unfamiliar areas. Stay alert for hidden hazards and traffic.
- After striking a foreign object, turn engine OFF, wait for moving parts to cease movement, and check immediately for damage. If damaged, repair before starting and operating snow thrower.
- With engine OFF, wait for moving parts to stop and always use a stick to clear discharge chute.
- If unit vibrates abnormally, turn engine OFF. Vibration is generally a warning of trouble. See an authorized dealer if necessary for repairs.



WARNING

Rotating gears can contact or entangle hands, feet, hair, clothing, or accessories.
Traumatic amputation or severe laceration can result.

- Always operate equipment with all guards in place.
- Keep hands and feet away from rotating gears.
- Tie up long hair and remove jewelry.
- Do not wear loose-fitting clothing, dangling drawstrings or items that could become caught.



DANGER

Discharge chute contains rotating impeller to throw snow.
Never clear or unclog discharge chute with your hands, or while engine is running.
Fingers can quickly become caught and traumatic amputation or severe laceration can result.

- Unclogging the discharge chute is a hazardous activity. Clogged or blocked augers store energy and can rotate unexpectedly.
- Never place hands in or near discharge chute.
- With engine OFF, wait for all moving parts to cease movement, then with a stick, clear the chute. Even with engine off, parts may rotate and dismemberment can occur.
- Clogged snow can hide other obstructions in the chute and cause damage to the equipment, impeller or auger. Take precautions when restating the equipment after snow removal.







WARNING



Engines give off carbon monoxide, an odorless, colorless, poison gas.
Breathing carbon monoxide can cause nausea, fainting or death.

- Start and run engine outdoors.
- Do not start or run engine in enclosed area, even if doors or windows are open.

RULES FOR SAFE OPERATION

 	<p>WARNING</p> <p>Gasoline and its vapors are extremely flammable and explosive. Fire or explosion can cause severe burns or death.</p> <p>WHEN ADDING FUEL</p> <ul style="list-style-type: none">• Turn engine OFF and let engine cool at least 2 minutes before removing gas cap.• Fill fuel tank outdoors or in well-ventilated area.• Do not overfill fuel tank.• Keep gasoline away from sparks, open flames, pilot lights, heat, and other ignition sources.• Check fuel lines, tank, cap, and fittings frequently for cracks or leaks. Replace if necessary. <p>WHEN STARTING ENGINE</p> <ul style="list-style-type: none">• Make sure spark plug, muffler, fuel cap and air cleaner are in place.• Do not crank engine with spark plug removed.• If fuel spills, wait until it evaporates before starting engine.• If engine floods, set choke to OPEN/RUN position, place throttle in FAST and crank until engine starts. <p>WHEN OPERATING EQUIPMENT</p> <ul style="list-style-type: none">• Do not choke carburetor to stop engine. <p>WHEN TRANSPORTING EQUIPMENT</p> <ul style="list-style-type: none">• Transport with fuel tank EMPTY. <p>WHEN STORING GASOLINE OR EQUIPMENT WITH FUEL IN TANK</p> <ul style="list-style-type: none">• Store away from furnaces, stoves, water heaters or other appliances that have pilot light or other ignition source because they can ignite gasoline vapors.
--	--

 	<p>WARNING</p> <p>Starting engine creates sparking. Sparking can ignite nearby flammable gases. Explosion and fire could result.</p> <ul style="list-style-type: none">• If there is natural or LP gas leakage in area, do not start engine.• Do not use pressurized starting fluids because vapors are flammable.
--	--

 	<p>WARNING</p> <p>Running engines produce heat. Engine parts, especially muffler, become extremely hot. Severe thermal burns can occur on contact. Combustible debris, such as leaves, grass, brush, etc. can catch fire.</p> <ul style="list-style-type: none">• Allow muffler, engine cylinder and fins to cool before touching.• Remove accumulated combustibles from muffler area and cylinder area.• Install and maintain in working order a spark arrester before using equipment on forest-covered, grass-covered, brush-covered unimproved land. The state of California requires this (Section 4442 of the California Public Resources Code). Other states may have similar laws. Federal laws apply on federal land.
--	---





  	<p>WARNING</p> <p>Unintentional sparking can result in fire or electric shock. Unintentional start-up can result in entanglement, traumatic amputation, or laceration.</p> <p>BEFORE PERFORMING ADJUSTMENTS OR REPAIRS</p> <ul style="list-style-type: none">• Disconnect spark plug wire and keep it away from spark plug. <p>WHEN TESTING FOR SPARK</p> <ul style="list-style-type: none">• Use approved spark plug tester.• Do not check for spark with spark plug removed.
---	--

TABLE OF CONTENTS

HAZARD SYMBOLS AND THE MEANINGS	3
OPERATING SYMBOLS AND THEIR MEANINGS	3
SAFETY DECALS	7
WARRANTY	8
OWNER'S INFORMATION	8
ASSEMBLY	9
TOOLS REQUIRED FOR ASSEMBLY	9
CONTENTS OF SHIPPING CARTON	9
PARTS BAGS CONTENTS	9
UNPACKING	10
UPPER HANDLE AND CRANK ASSEMBLY	11
CHECK THE CABLES	11
HOW TO SET THE LENGTH OF THE CABLES	11
REMOTE CHUTE CONTROL KNOB	12
SPEED SELECT KNOB	12
HOW TO INSTALL THE SPEED CONTROL ROD	12
SNOW CHUTE ASSEMBLY	13
OPERATION	14
ENGINE AND SNOWTHROWER CONTROLS	14
SNOWTHROWER OPERATION	15
HOW TO SET THE DRIFT CUTTERS	16
BEFORE STARTING ENGINE	17
CHECK THE OIL	17
FILL GAS	17
TO STOP ENGINE	18
TO START ENGINE	18
HOW TO CLEAR A CLOGGED DISCHARGE CHUTE	20
HOW TO USE THE CLEAN-OUT TOOL	20
OPERATING TIPS	21
SERVICE RECOMMENDATIONS	22
MAINTENANCE	23
LUBRICATION	23
ENGINE	25
AUGER HOUSING HEIGHT ADJUSTMENT	26
BELT ADJUSTMENT	27
HOW TO REPLACE THE BELTS	28
BELT GUIDE ADJUSTMENT	31
TRACTION DRIVE CABLE ADJUSTMENT	32
HOW TO ADJUST OR REPLACE THE FRICTION WHEEL	33
HOW TO REMOVE THE SNOW HOOD	36
AUGER SHEAR BOLT REPLACEMENT	37
TO ADJUST OR REPLACE THE SPARK PLUG	37
STORAGE	38
TROUBLE SHOOTING CHART	39
REPLACEMENT PARTS	40
PARTS SCHEMATICS	41
SPECIFICATIONS	60

SAFETY DECALS

 **WARNING:** If safety decals are damaged or missing, replace immediately. 

 **Look for this symbol to indicate important safety precautions. This symbol indicates: “Attention! Become Alert! Your Safety Is At Risk.”**

Before operation of your snowthrower, read the safety decals as shown on your snowthrower. The cautions and warnings are for your safety. To avoid a personal injury or damage to your snowthrower, understand and follow all safety decals. If you have any questions regarding the meaning or how to comply with the instructions, do not operate until you understand the purpose for the warning or danger given in the safety decal. If you do not understand

the meaning, then thoroughly read all safety and operation instructions in this Owner’s Manual or contact your local dealer.

If any safety decals become worn or damaged and cannot be read, order replacement decals from your local dealer.

Identifying Your Snowthrower

The snowthrower has two (2) identifying numbers: (1) unit model number: (2) unit serial number. The two preceding numbers are required to insure that the proper replacement parts are obtained when required. If you have any questions concerning parts, service, or technical data, contact the dealer where the unit was purchased. For complete warranty information refer to the warranty in the Owner’s Information section of this manual.

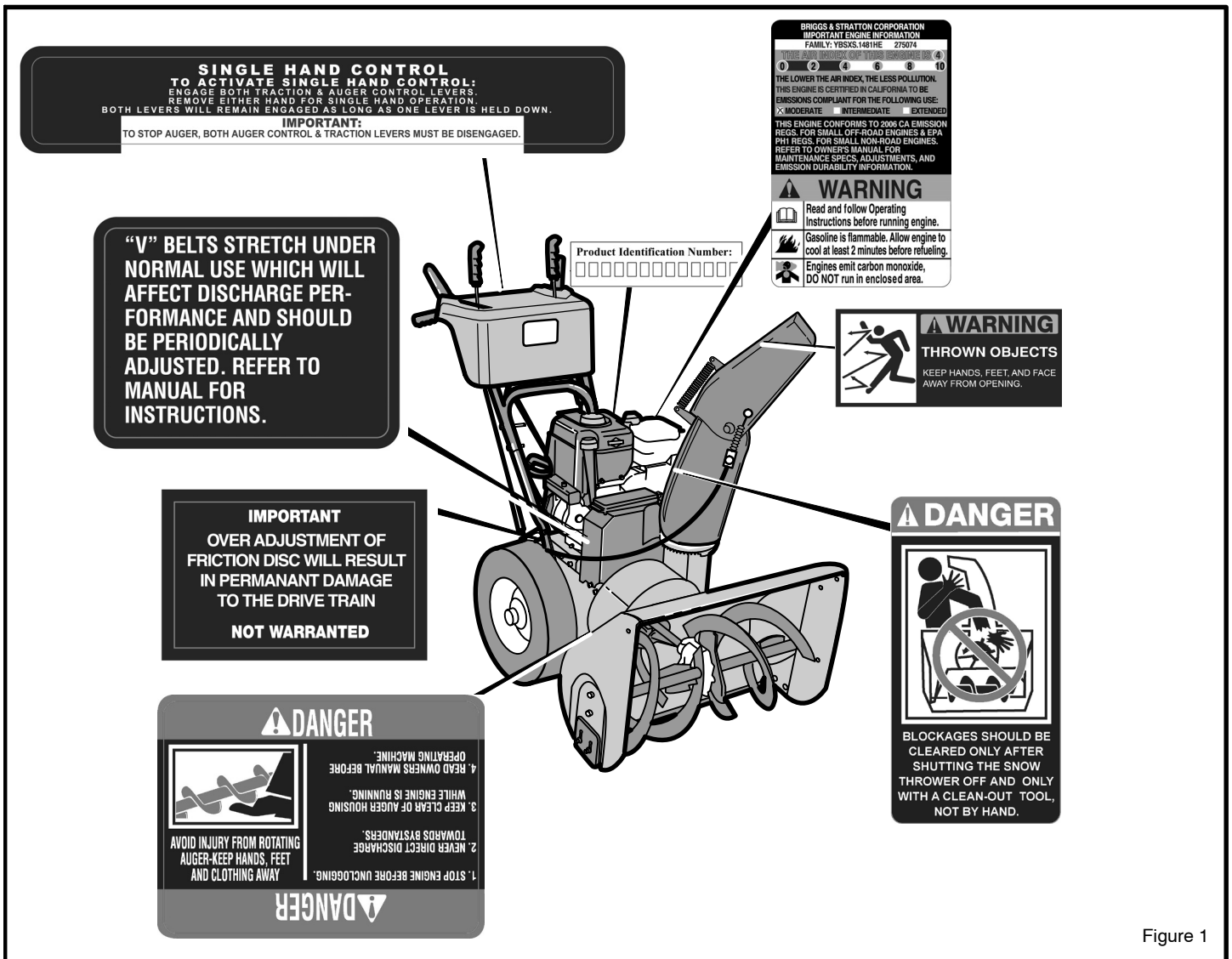

Figure 1

OWNER'S INFORMATION

THREE YEAR LIMITED WARRANTY

Murray warrants to the original purchaser of this Frontier Branded Snowthrower that this unit shall be free from defects in material and workmanship under normal use and service for a period of **Three (3) Year** from the date of purchase; however, this warranty does not cover accessories (such as electric starters) and Normal Wear Parts (except as noted below) as the companies that manufacture these items furnish their own warranties and provide service through their authorized field service facilities. For additional information, see the warranties covering these particular parts. If you are uncertain whether your unit contains or is equipped with one or more of these parts, consult your dealer prior to purchase. Subject to the terms and conditions noted in this Limited Warranty, we shall, at our option, repair or replace at no cost to the original purchaser any part covered by this Limited Warranty during the applicable warranty period.

Normal Wear Parts are defined as drive belts, augers, shear pins, tires and headlights. These parts are warranted to be free from defects in material and workmanship as delivered with the product. Any claim for repair or replacement of Normal Wear Parts must be made within thirty (30) days of the date of purchase. No claims involving damage caused from material use, abuse or misuse will be honored.

This Murray **Three (3) Year Limited Warranty** for your Frontier Branded Snowthrower is your exclusive remedy; however, this warranty is void or does not apply to any unit that has been tampered with, altered, misused, abused. If used for commercial and/or professional (non-homeowner) uses, the duration of this warranty is ninety (90) days after the date of purchase. Your warranty does not cover minor mechanical adjustments which are not due to any defect in material or workmanship. For assistance in making such adjustments, consult your Operator's Manual.

The engine on this Frontier Branded Snowthrower is warranted to the original purchaser for a **Three (3) Year Limited Warranty** by the equipment manufacturer. See your engine manual for information regarding the warranty policy and items covered under warranty. See your authorized John Deere/Frontier Dealer for service or replacement parts. **MB**

To make a claim under this Murray **Three (3) Year Limited Warranty** for your Frontier Branded Snowthrower, return the unit (or if authorized in advance, the defective part) along with your proof of purchase to an Authorized John Deere/Frontier Dealer near you. To locate the nearest Authorized John Deere/Frontier Dealer, check the Yellow Page listings in your local telephone directory. If you return the entire unit, John Deere/Frontier will repair all warranty items. If authorize to return the defective part only, John Deere/Frontier will either replace or repair the part. This Murray **Three (3) Year Limited Warranty** for your Frontier Branded Snowthrower gives you specific legal rights, and you may also have other rights which vary from state to state. **This Limited Warranty is given in lieu of all other expressed and implied warranties including the implied warranty of merchantability and warranty of fitness for a particular purpose.** If you need additional information on this written warranty or assistance in obtaining service, contact you local John Deere/Frontier Dealer.

FOR YOUR RECORDS

DATE PURCHASED: _____

MODEL NO: _____

SERIAL NO: _____

STORE WHERE PURCHASED: _____

ADDRESS: _____

CITY: _____ STATE: _____

TELEPHONE : _____

Record this information about your unit so that you will be able to provide it in case of loss or theft.

ASSEMBLY

TOOLS REQUIRED FOR ASSEMBLY

- 1 – Knife
- 2 – 1/2" wrenches (or adjustable wrenches)
- 2 – 9/16" wrenches (or adjustable wrenches)
- 2 – 3/4" wrenches (or adjustable wrenches)
- 1 – 3/8" wrenches (or adjustable wrenches)
- 1 – Pair pliers or screw driver (to spread cotter pin)

CONTENTS OF SHIPPING CARTON

- 1 – Snowthrower
- 1 – Container of Fuel Stabilizer (Located in Parts Bag)
- 1 – Crank Assembly
- 1 – Parts Bag

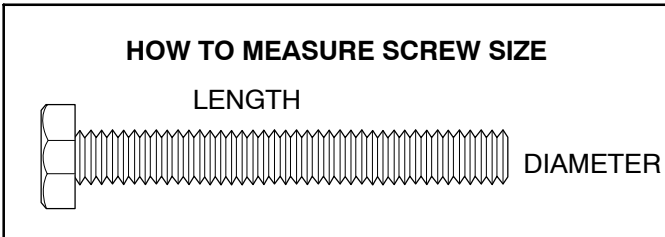

WARNING: Always wear safety glasses or eye shields while assembling snowthrower.

PARTS BAGS CONTENTS:

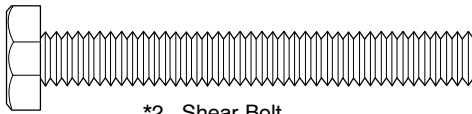

*2- Shear Bolt

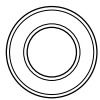

* 2- Spacer

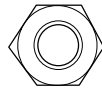

*2- Nut



1 – Shift Lever Knob
(not actual size)



1 – Remote Chute Knob
(not actual size)



1 – Washer

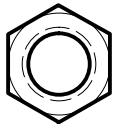

1 – Nut

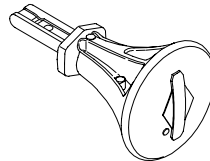

1 – Ignition Keys

* Non Assembly parts are found in toolbox located on top of belt cover.

ASSEMBLY

Figure 2 shows the snowthrower in the shipping position.

Figure 3 shows the snowthrower completely assembled.

Reference to right and left hand side of the snowthrower is from the operator's position at the handle.

UNPACKING

1. Locate the two tear tabs at the bottom of the carton.
2. Pull the tear tape no more than twelve inches (30.48cm.) at a time. Re-grasp tape next to the carton and pull again. Repeat until all the tape is torn off.
3. After the tape has been completely removed from the carton, remove the carton from the base. Cut all four corners and fold the sides toward the center for easy disposal.
4. Remove the plastic bag that covers the unit.
5. Locate and remove the parts bag.

NOTE: Set the fuel stabilizer aside until adding gasoline to the fuel tank. We recommend that fuel stabilizer is added to the fuel each time that gasoline is added to the fuel tank.

6. For shipping purposes, the **height adjust skids** are attached to the pallet. Remove the **screw** that secures each **height adjust skid** to the pallet. (See Figure 2).
7. Roll the snowthrower off the carton by pulling on the lower handle.

CAUTION: DO NOT back over cables.

8. Remove the packing material from the handle assembly.
9. Cut ties securing the clutch control cables to the lower handle.

NOTE: If the cables have become disconnected from the clutch levers, reinstall the cables as shown in Figure 4.

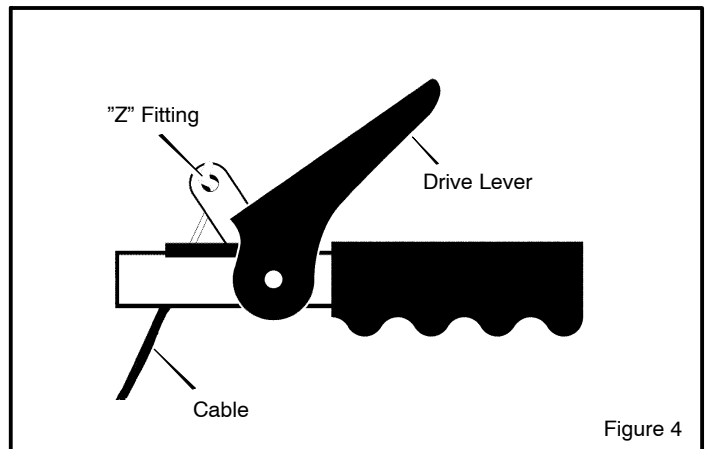
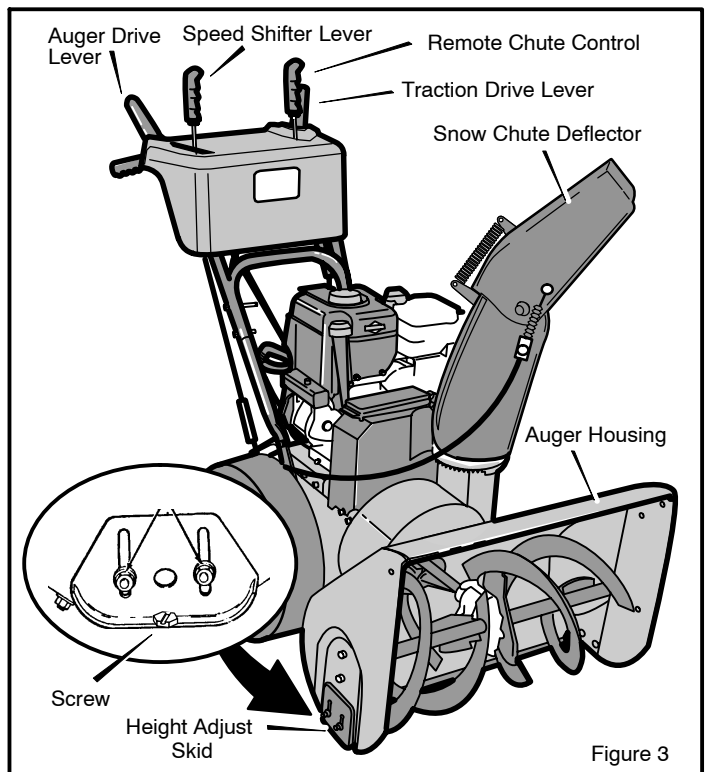
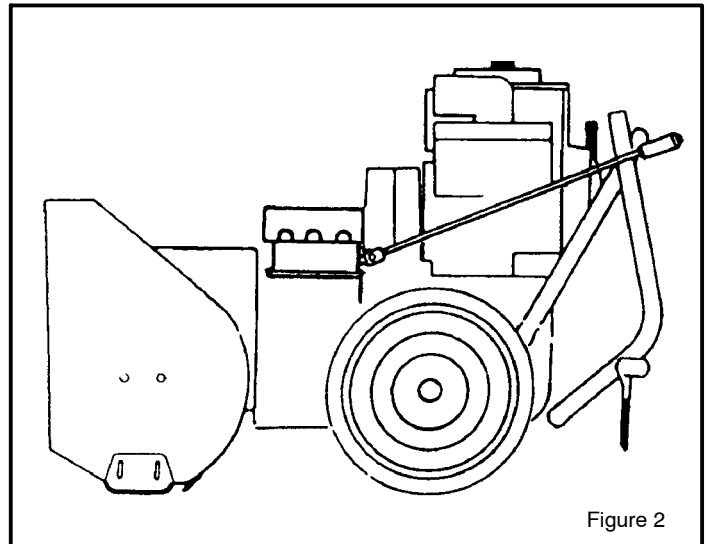

ASSEMBLY

UPPER HANDLE AND CRANK ASSEMBLY

For shipping purposes, the handles were assembled together with the fasteners in the **LOWER holes**. When assembled, *make sure* that the **fasteners** are in the **UPPER holes** and that the **eye bolt** is mounted in the **LOWER hole** on the left side as shown in Figure 5.

1. On the *right side* of the handle, loosen, but do not remove the fasteners (bolt, flatwasher, lockwasher and nut) that are assembled in the lower hole.
2. On the *left side* of the handle, remove the fasteners (bolt, flatwasher, lockwasher and nut) that are assembled in the LOWER holes.
3. Remove the fasteners and the crank assembly eyebolt from the UPPER holes of the lower handle.
4. Raise upper handle into operating position. Upper handle should be to the outside of the lower handle.

NOTE: Make sure the cables are not caught between the upper and lower handle.

5. On the *left side* of the handle, install the fasteners that were removed in step 2. Make sure these fasteners are installed in the UPPER holes as shown in Figure 5.
6. Install the fasteners and the crank assembly eyebolt that were removed in step 3. Make sure to install the eyebolt in the LOWER holes as shown in Figure 5. **DO NOT** tighten until all fasteners are in place.
7. Attach the crank rod to the universal joint assembly with the hair pin (see Figure 6).
8. Tighten nut on eye bolt. Make sure eye bolt is properly aligned and the crank can freely rotate.
9. Tighten all handle bolts.

NOTE: Make sure crank does not touch carburetor cover.

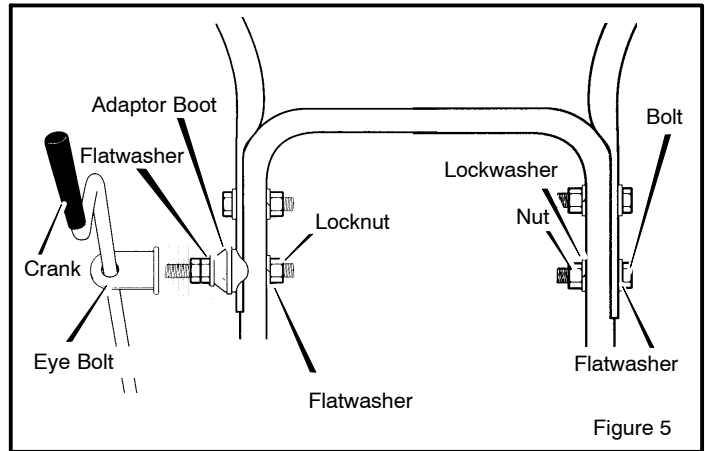

Figure 5

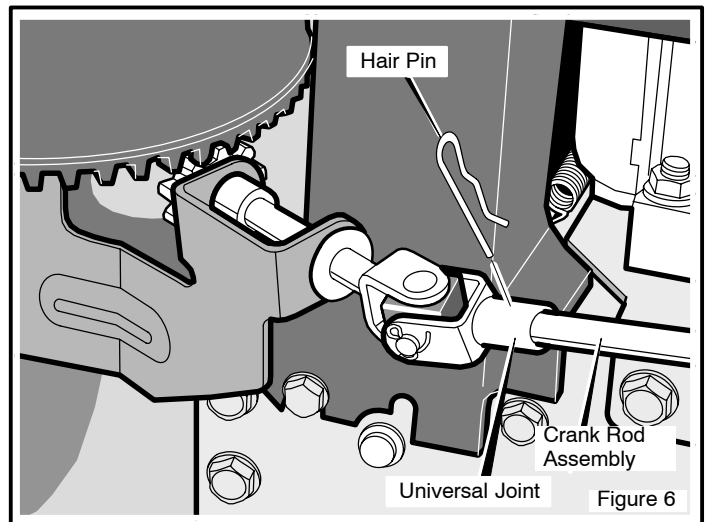

Figure 6

CHECK THE CABLES

1. If control cables have become unattached from motor mount frame, reconnect cables as shown in Figure 7.
2. For cable adjustments, see “How To Check And Adjust The Cables” in the MAINTENANCE section.

HOW TO SET THE LENGTH OF THE CABLES

The cables were adjusted at the factory and no adjustments should be necessary. However, after the handles are put in the operating position, the cables can be too tight or too loose. If an adjustment is necessary, see “How To Check And Adjust The Cables” in the MAINTENANCE section.

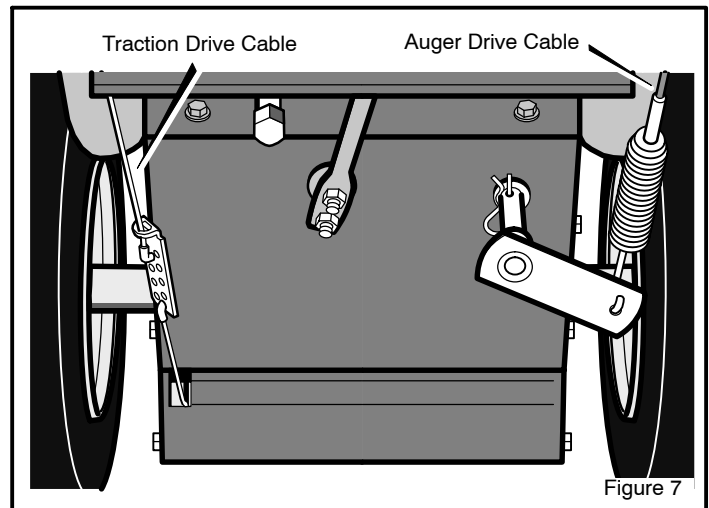

Figure 7

ASSEMBLY

REMOTE CHUTE CONTROL KNOB

1. Thread the knob onto the lever as far as possible.- Make sure that the knob points forward (See Figure 8).
2. Tighten the jam nut against the knob securely.

SPEED SELECT KNOB

1. Thread the knob onto the lever as far as possible. Make sure that the knob points forward (See Figure 8).
2. Tighten the jam nut against the knob securely.

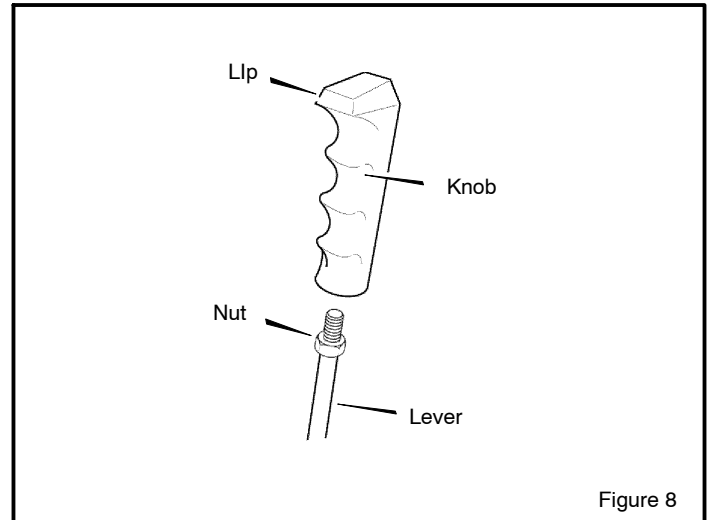

HOW TO INSTALL THE SPEED CONTROL ROD

1. Put the **speed select lever** to the NEUTRAL position. See Figure 9.
2. Attach the **ball joint**, located on the bottom end of the **speed control rod**, to the **shift yoke assembly**. See Figure 10. The **fasteners** (washer and nut) are in the parts bag.
3. The length of the **ball joint** and **speed control rod** have been pre-adjusted at the factory. If an adjustment is required, loosen the **nut**. Remove the **fasteners** to disconnect the **ball joint** from the **shift yoke assembly**. To lengthen or shorten the **speed control rod**, turn the **adapter** to obtain the correct length.
4. Make sure the **speed select lever** functions correctly. Move the **speed select lever** through all speeds.

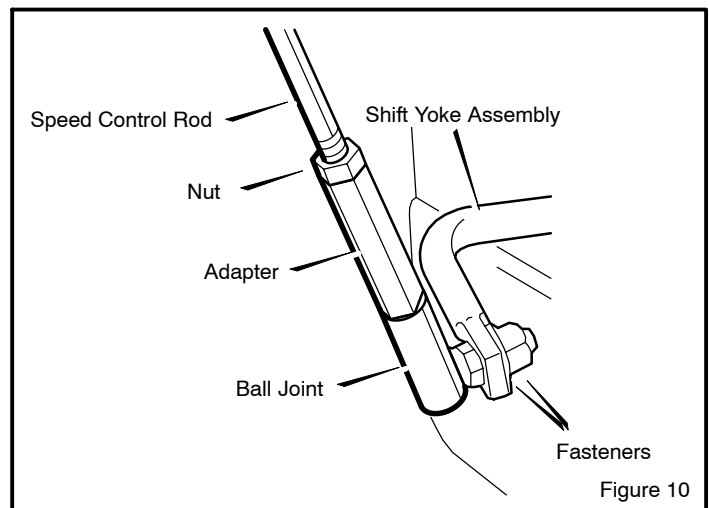
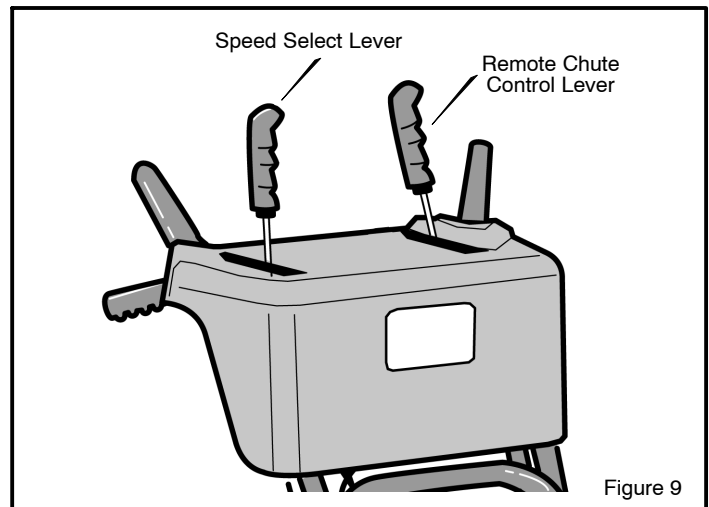

ASSEMBLY

SNOW CHUTE ASSEMBLY

1. Remove back carriage bolt (See Figure 11).
2. Tilt chute back into operating position.
3. Replace carriage bolt from inside of chute.
4. Replace flatwasher and nylon locknut on outside of flange.
5. Tighten carriage bolt securely.

NOTE: check all carriage bolts in flange for tightness. DO NOT overtighten.

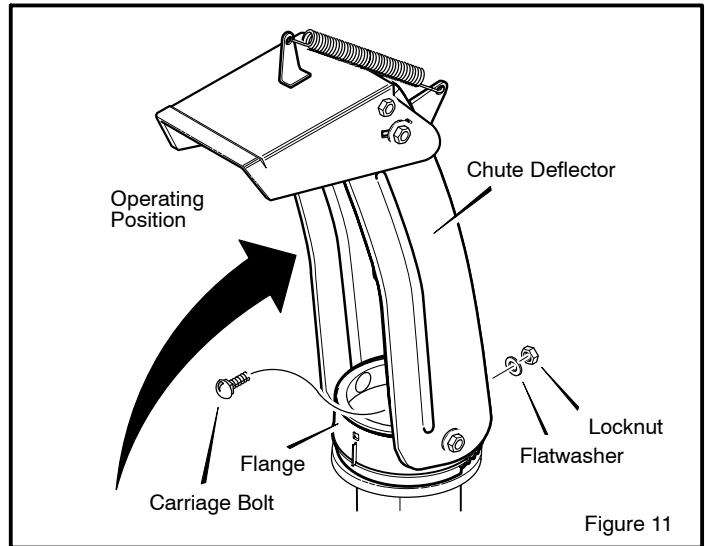

CHECK THE TIRES

The tires were over inflated for shipment. Check the tire pressure in the tires. See the sidewall of the tire for the proper inflation.

IMPORTANT! BEFORE YOU START OPERATING

- Check the fasteners. Make sure all fasteners are tight.
- On electric start models, the unit was shipped with the starter cord plugged into the engine. Before operating, unplug the starter cord from the engine.

NOTE: This snowthrower was shipped WITH OIL in the engine. See "Before Starting Engine" instructions in the Operation section of this manual before starting engine.

OPERATION

READ THIS OWNER'S MANUAL AND SAFETY RULES BEFORE OPERATING YOUR SNOWTHROWER. Compare the illustrations with your SNOWTHROWER to familiarize yourself with the location of various controls and adjustments. Save this manual for future reference.

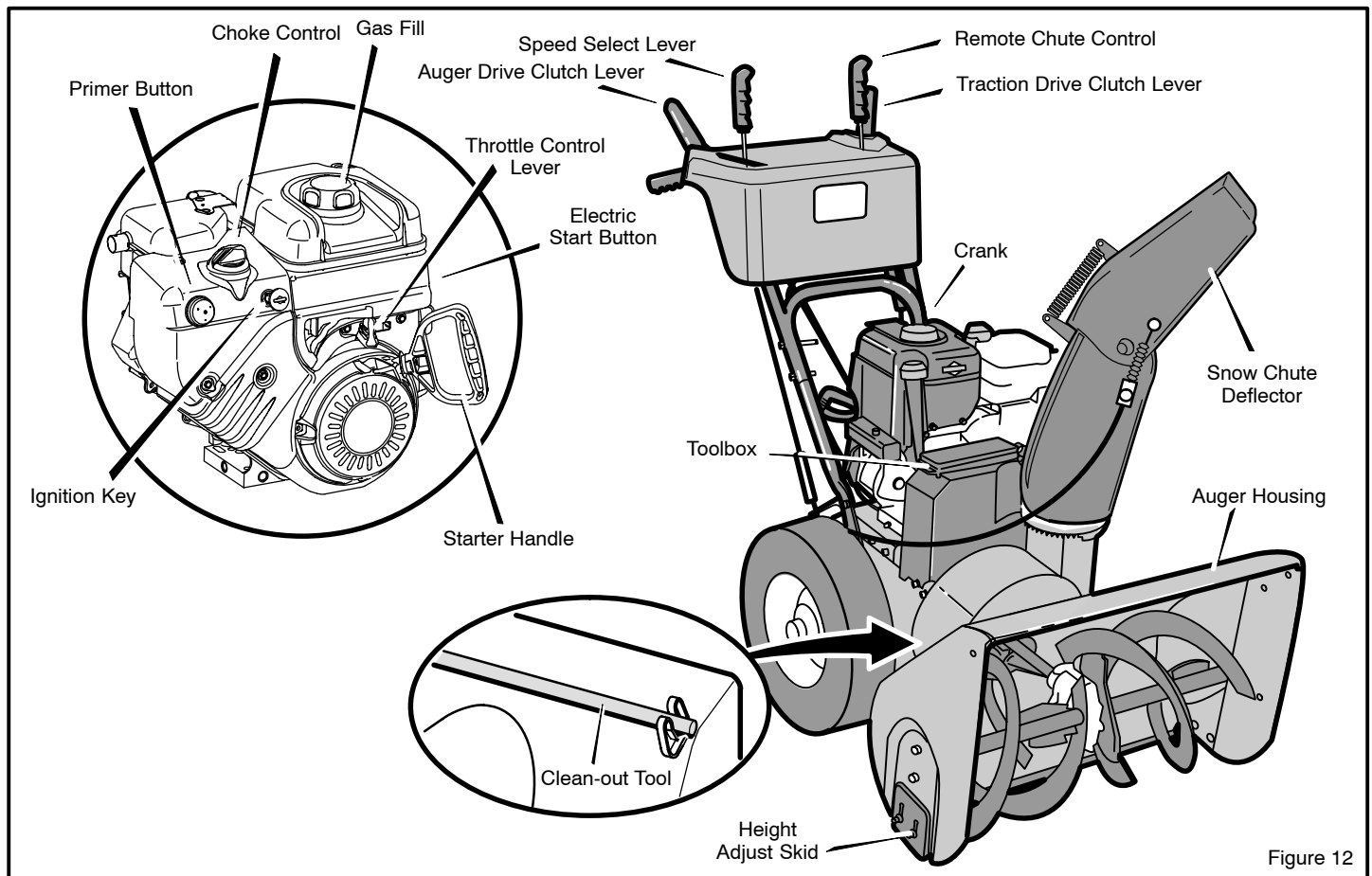

ENGINE AND SNOWTHROWER CONTROLS

ENGINE CONTROLS

Throttle Control Lever – Controls the engine speed.

Choke Control– Use to start a cold engine.

Electric Start Button– Used to start the engine using the 120 volt electric starter.

Prime Button– Used to inject fuel directly into carburetor manifold to insure fast starts in cool weather.

Ignition Key– Must be inserted to start engine. Pull out to stop. Do not turn ignition key.

Starter Handle– Starts the engine manually.

SNOWTHROWER CONTROLS

Speed Select Lever– Allows the operator to use one of six (6) forward and two (2) reverse speeds. To shift, move speed select lever to desired position.

NOTE: Do not move speed select lever while Traction Drive Clutch is engaged. This may result in severe damage to drive system.

Auger Drive Clutch Lever– Used to engage and disengage the auger and impeller. To engage push down, to disengage release.

Traction Drive Clutch Lever– Used to propel snow blower forward or reverse. Push down to engage, release to disengage.

Snow Chute Deflector– Changes the direction the snow is blown.

Remote Chute Control– Push forward to discharge snow down. Pull back to discharge snow high and far.

Crank– Used to change direction of the snow discharge. Turn handle clockwise to turn chute to right. Turn handle counter clockwise to turn chute to left.

Height Adjust Skid– Used to adjust ground clearance of auger housing.

Toolbox – Spare shear pins and spacers are located in toolbox.

Clean-Out Tool – Use the clean-out tool to remove snow and debris from the discharge chute and the auger housing.

OPERATION



The operation of any snowthrower can result in foreign objects being thrown into the eyes, which can result in severe eye damage. Always wear safety glasses or eye shields before beginning snowthrower operation. We recommend standard safety glasses or Wide Vision Safety Mask for over spectacles.

SNOWTHROWER OPERATION

The most effective use of the snowthrower will be established by experience, taking into consideration the terrain, wind conditions and building location which will determine the direction of the discharge chute.

NOTE: Do not blow snow toward a building as hidden objects could be blown with sufficient force to cause damage.

TO STOP YOUR SNOWTHROWER

1. To stop throwing snow, release the **auger drive lever**. (see Figure 13).
2. To stop the wheels, release the **traction drive lever**.
3. To stop the engine, push the **throttle control lever** to off and pull out the **ignition key**.

TO CONTROL SNOW DISCHARGE

1. Rotate the **crank** to set the direction (left to right) of the discharge chute (see Figure 12).
2. Push the **remote chute lever** forward to discharge the snow down. Pull the **remote chute lever** back to discharge the snow high and far (see Figure 13).

HOW TO MOVE FORWARD AND BACKWARD

1. Start the engine. See "To Start Engine" in the Operation section.

NOTE: Always release the traction drive lever before moving the speed select lever.

2. Ground speed is determined by snow conditions. Set the **speed select lever** in one of the following positions.

- | | |
|-----|--------------------------------|
| 1-2 | Wet, Heavy, Slushy, Extra Deep |
| 3 | Moderate |
| 4-5 | Very Light |
| 6 | Transport Only |

IMPORTANT: Before operating, make sure the area in front of snowthrower is clear of bystanders or obstacles.

3. Engage the **traction drive lever** (see Figure 13). As the snowthrower starts to move, maintain a firm hold on the handles and guide the snowthrower along the cutting path. Do not attempt to push the snowthrower.
4. To stop forward motion, release the **traction drive lever**.
5. To move the snowthrower backwards, move the **speed select lever** into either first or second reverse position and engage the **traction drive lever**.

TO THROW SNOW

1. Push down the **auger driver lever (right hand)**. See Figure 13.
2. To stop throwing snow, release the **auger drive lever**.

NOTE: When clearing wet, heavy snow, it is recommended that the ground speed of the unit be reduced, maintain full throttle and do not attempt to clear the full width of the unit.

For additional operating instructions see "Operating Tips" in the Operation section.



WARNING: Read Owner's Manual before operating machine. This machine can be dangerous if used carelessly.

Never operate the snowthrower without all guards, covers, and shields in place.

Never direct discharge towards windows or allow bystanders near machine while engine is running.

Stop the engine whenever leaving the operating position.

Disconnect spark plug before unclogging the impeller housing or the discharge chute and before making repairs or adjustments.

When leaving the machine, remove the ignition key.

To reduce the risk of fire, keep the machine clean and free from spilled gas, oil and debris.

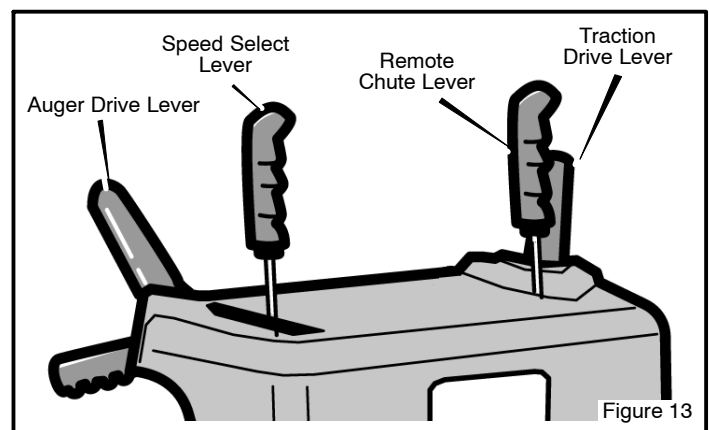

WARNING: Never run engine indoors or in an enclosed, poor ventilated area. Engine exhaust contains CARBON MONOXIDE, an ORDERLESS and DEADLY GAS.

Keep hands, feet, hair and loose clothing away from any moving parts on engine and snowthrower.

Temperature of muffler and nearby areas can exceed 150° F (66° C). Avoid these areas.

DO NOT allow children or young teenagers to operate or be near snowthrower while it is operating.

OPERATION

HOW TO USE THE WHEEL LOCKOUT

Each wheel is secured to the axle with a lockout pin. See Figure 14. The unit was shipped with the lockout pin in the locked position. For ease of maneuverability, disconnect the lockout pin as follows.

1. Pull the **knob** out to disengage the lockout pin.
2. To lock in the disengaged position, turn the **knob** 1/4 turn (90 degrees).

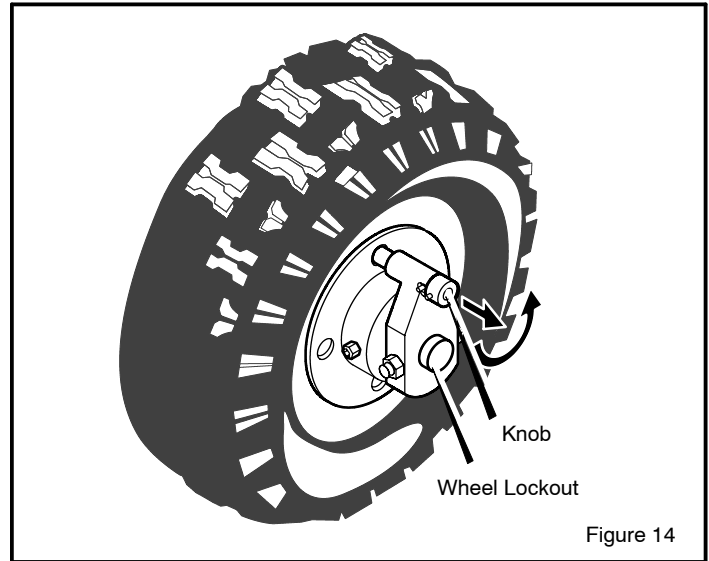

HOW TO SET THE DRIFT CUTTERS

(OPTIONAL ACCESSORY ON SOME MODELS)

Drift cutters are used to cut a path through snow deeper than the auger housing.

1. Loosen the **wingnuts** that secure the **drift cutters** to the auger housing (see Figure 15).
2. Raise the **drift cutters** to the desired height.
3. Tighten the **wingnuts**.

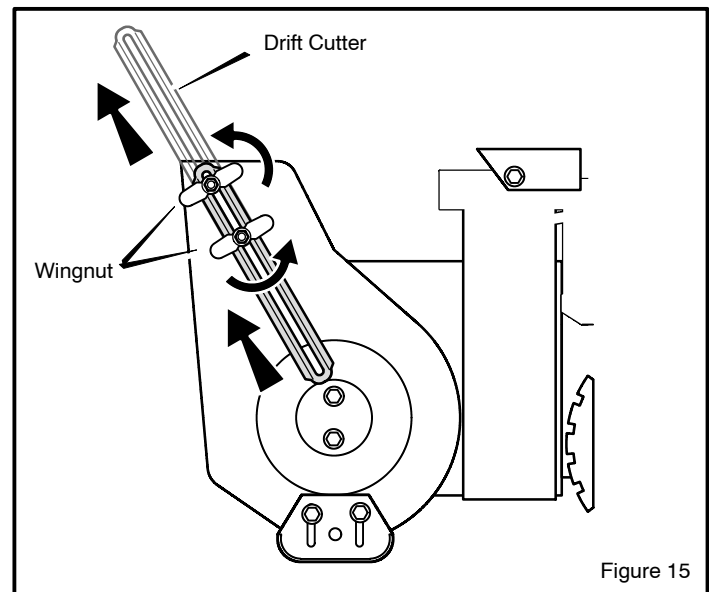

OPERATION

BEFORE STARTING ENGINE

Check the oil

NOTE: The engine was shipped from the factory filled with oil. Check the level of the oil. Add oil as needed.

1. Make sure the unit is level. Use a high quality detergent oil classified "For Service SG, SH, SJ, SL, or higher".
2. Remove the oil fill cap/dipstick and wipe with a clean cloth (see Figure 16).
3. Insert the oil fill cap/dipstick and turn clockwise to tighten.
4. Remove the oil fill cap/dipstick and check the oil.

NOTE: Do not check the level of the oil while the engine runs.

5. If necessary, add oil until the oil reaches the FULL mark on the oil fill/cap dipstick (see Figure 16). Do not add too much oil.
6. Tighten the fill cap/dipstick securely each time you check the oil level.

NOTE: For extreme cold operating conditions of 0°F (-18°C) and below, use a synthetic 5W30 motor oil for easier starting.

NOTE: S.A.E. 5W30 motor oil may be used to make starting easier in areas where the temperature is 20°F (-7°C) to 0°F (-18°C). Synthetic 5W30 is acceptable for all temperatures. DO NOT mix oil with gasoline.

NOTE: SEE CHART FOR OIL RECOMMENDATION

TEMPERATURE	TYPE OF OIL
0°F (-18°C) and above	S.A.E. 5W30
0°F (-18°C) and below	synthetic 5W30

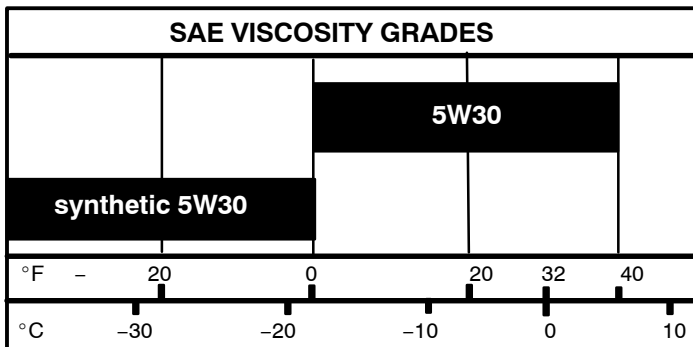

FILL GAS

This engine is certified to operate on gasoline. Exhaust Emission Control System: EM (Engine Modifications)

1. Fill the fuel tank with fresh, clean, unleaded regular, unleaded premium, or reformulated automotive gasoline with a minimum of 85 octane along with a fuel stabilizer (follow instructions on fuel stabilizer package). **DO NOT**

use leaded gasoline. We recommend that fuel stabilizer be added to the fuel each time that gasoline is added to the fuel tank.

NOTE: Winter grade gasoline has higher volatility to improve starting. Be certain container is clean and free from rust or other foreign particles. Never use gasoline that may be stale from long periods of storage in the container.

CAUTION: DO NOT use gasoline containing any amount of alcohol as it can cause serious damage to the engine or significantly reduce the performance.

2. Check to make sure that spark plug is tightened securely into engine and spark plug wire is attached to spark plug. If torque wrench is available, torque plug to 18–23 ft-lbs.



WARNING: Gasoline is flammable. Always use caution when handling or storing gasoline. Do not add gasoline to the fuel tank while snow blower is running, hot, or when snow blower is in an enclosed area. Keep away from open flame, electrical sparks and DO NOT SMOKE while filling the fuel tank. Never fill the fuel tank completely; but fill the fuel tank to within 1-1/2 inch (3.8 mm) from the top to provide space for the expansion of the fuel. Always fill fuel tank outdoors and use a funnel or spout to prevent spilling. Make sure to wipe up any spilled fuel before starting the engine.

Store gasoline in a clean, approved container, and keep the cap in place on the container. Keep gasoline in a cool well ventilated place; never in the house. Never buy more than a 30 day supply of gasoline to assure volatility. Gasoline is intended to be used as a fuel for internal combustion engines; therefore, do not use gasoline for any other purpose. Since many children like the smell of gasoline, keep it out of their reach because the fumes are dangerous to inhale, as well as being explosive.

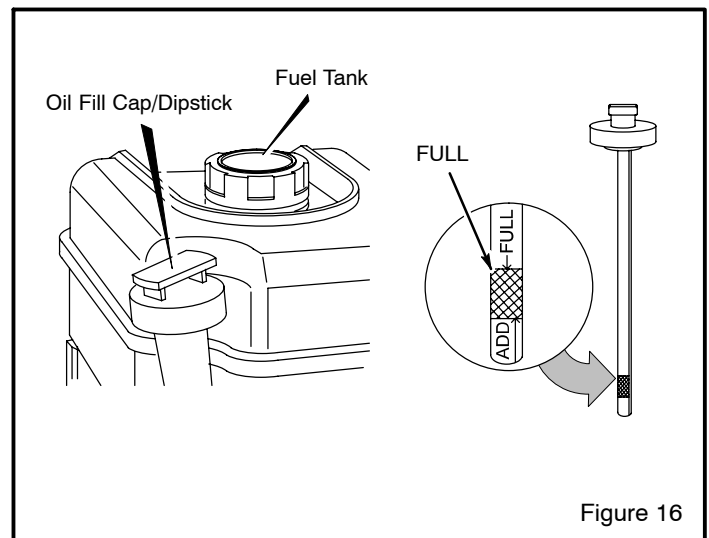

Figure 16

BEFORE STOPPING THE ENGINE

Run the engine for a few minutes to help dry off any moisture on the engine.

OPERATION

TO STOP ENGINE

CAUTION: To stop the engine, do not move the choke control to CHOKE position. Backfire or engine damage can occur.

1. Move throttle control to SLOW, then to STOP (Figure 17).

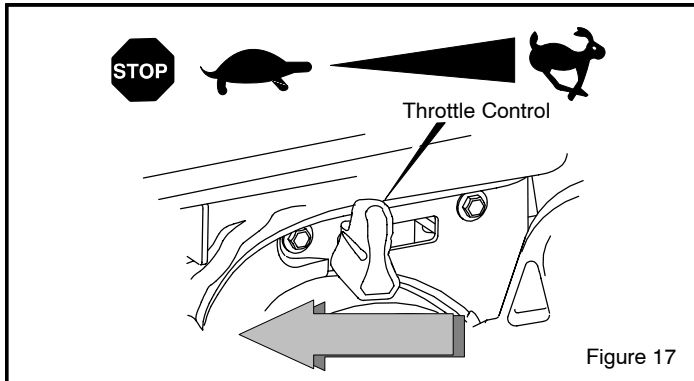

2. Pull out safety/ignition key (Figure 18).

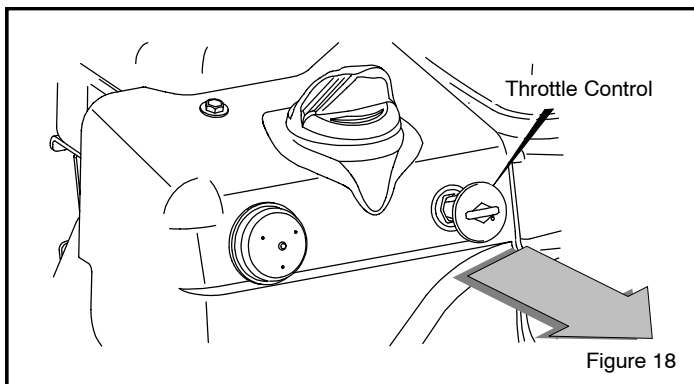

TO START ENGINE

Be sure that engine has sufficient oil. Use a high quality detergent oil classified "For Service SG, SH, SJ, SL, or higher".

The snow thrower engine is equipped with a 120 volt A.C. electric starter and recoil starter. Before starting the engine, be certain that you have read the following information.

If engine floods, set the choke to the OPEN/RUN position and crank until the engine starts.

WARNING: Rapid retraction of the starter cord (kickback) will pull your hand or arm toward the engine faster than you can let go of the starter cord.

- When starting the engine, slowly pull the starter cord until resistance is felt. Then, rapidly pull the starter cord.
- Make sure components; such as impellers, pulleys or sprockets, are securely attached.



WARNING: The electric starter is equipped with a three-wire power cord and plug designed to operate on 120 volt AC house hold current. The power cord must be properly grounded at all times to avoid the possibility of electric shock which can cause injury to the operator. Follow all instructions carefully as set forth below:

Make sure your house has a three-wire grounded system. If you are not sure, ask a licensed electrician. If your house does not have a three-wire grounded system, do not use this electric starter under any condition.

If your house has a three-wire grounded system but a three hole receptacle is not available to connect the electric starter, have a three-hole receptacle installed by a licensed electrician.



WARNING: To connect a 120 volt power cord, always connect the power cord first to the switch box located on the engine and then plug the other end into a three-hole grounded receptacle.



WARNING: To disconnect the power cord, always unplug the end connected to the three-hole grounded receptacle first.

COLD ENGINE START

(Engine has not been run recently.)

1. Be sure auger drive clutch lever and traction drive clutch lever are in the disengaged (RELEASED) position.
2. Move throttle control to "FAST" position. Operate the engine with the throttle control in FAST position (Figure 19). Before engaging auger drive clutch lever allow engine to idle for five minutes to allow engine oil to warm. Failure to allow engine oil to warm can cause damage to engine.

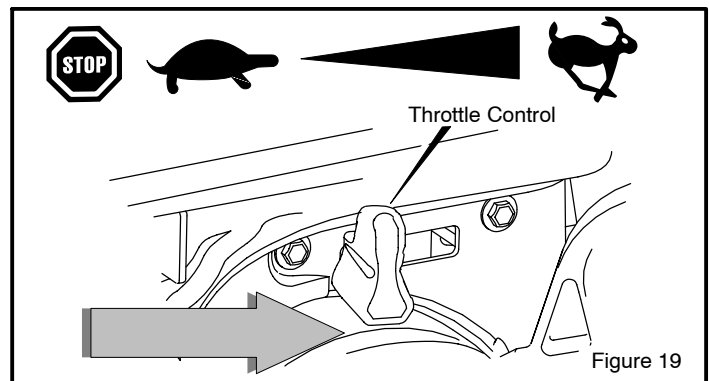

3. Insert key into ignition slot. Make sure it snaps into place (Figure 20). Do not turn key.
4. Rotate choke knob to the CHOKE position.
5. Push the primer button as follows:
Above 50° F (10° C), DO NOT PRIME.
From 50° F (10° C) to 15° F (-10° C), PUSH TWO TIMES.
Below 15° F (-10° C), PUSH FOUR TIMES.

OPERATION

NOTE: Cover the vent hole when as you push the primer. Remove your finger from the primer vent hole between pushes.

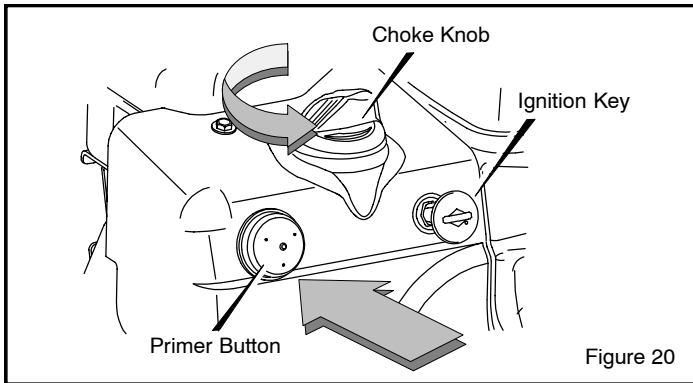

Figure 20

6. **(RECOIL START)** Slowly pull the **recoil starter handle** until resistance is felt and then pull rapidly to start the engine (Figure 21). Do not allow the **recoil starter handle** to snap back. Slowly return the **recoil starter handle**.

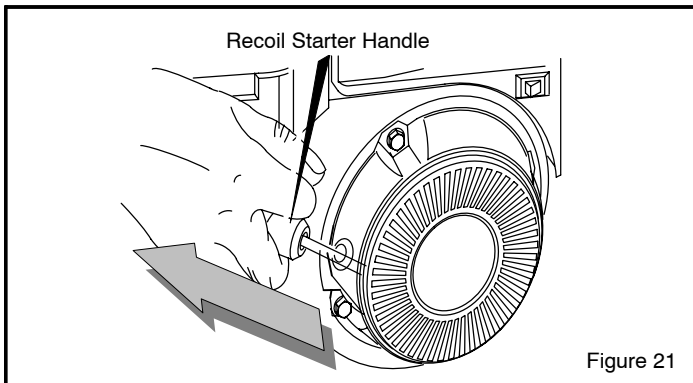

Figure 21

7. **(ELECTRIC START)** Connect the power cord to the engine and depress the starter button (Figure 22). To prolong the life of the starter, do not crank for more than 5 seconds at a time. Wait one minute between starts to allow the starter motor to cool.

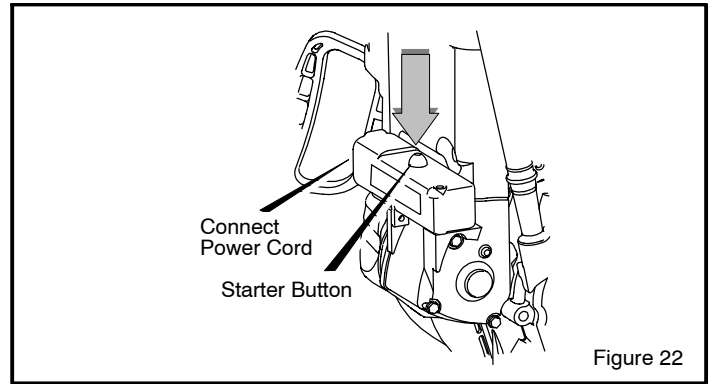

Figure 22

8. If the engine does not start in 5 or 6 tries, See **Difficult Starting** in the "Troubleshooting Table".
9. As engine warms up move choke lever to "1/2 choke" position. When engine does not run smoothly, move choke lever to the off position.

NOTE: Allow the engine to warm up for several minutes before blowing snow in temperatures below 0°F (-18° C).

10. **(Electric Start)** First disconnect power cord from receptacle. Then, disconnect the power cord from the **switch box**.

If after following the preceding instructions, your engine fails to start, have the engine checked by a John Deere/Frontier dealer.

NOTE: Do not lose the safety/ignition key. Keep the safety/ignition key in a safe place. The engine will not start without the safety/ignition key.

WARM ENGINE START (RECOIL STARTER)

If restarting a warm engine after a short shutdown, leave choke at "OFF" and do not push the primer button. If the engine fails to start, follow the Cold Start instructions.

OPERATION

FROZEN STARTER

If the starter is frozen and will not turn engine:

1. Pull as much rope out of the starter as possible.
2. Release the starter handle and let it snap back against the starter. Repeat until the engine starts.

Warm engines will cause condensation in cold weather. To help prevent possible freeze-up of recoil starter and engine controls, proceed as follows after each snow removal job.

1. With engine off, allow engine to cool for several minutes.
2. Pull starter rope very slowly until resistance is felt, then stop. Allow the starter rope to recoil. Repeat three times.
3. With the engine not running, wipe all snow and moisture from the carburetor cover in area of control levers. Also move choke knob and starter handle several times.
4. With engine not running, wipe all snow and moisture from carburetor cover in area of control levers. Also move control levers backward and forward several times.



WARNING: Never run engine indoors or in enclosed, poorly ventilated areas. Engine exhaust contains **CARBON MONOXIDE, AN ODORLESS AND DEADLY GAS**. Keep hands, feet, hair and loose clothing away from any moving parts on engine and snow thrower.

- Engine parts, especially the muffler, become extremely hot. Severe thermal burns can occur on contact. Allow the engine to cool before touching.
- Never allow children to operate the snow thrower. Never allow adults to operate the snow blower without proper instruction.
- Keep the area of operation clear of all persons, particularly small children and pets.
- Never leave the snow blower unattended while the engine is running. Anyone operating the engine or equipment must carefully read and understand the operating instructions.

IMPORTANT: After each use of the snow blower, stop the engine, remove the safety/ignition key, remove all accumulated snow from the snow blower and wipe clean. Store the snow blower in a protected area.

NOTE: Never cover snow blower while engine and exhaust area are still warm.

HOW TO CLEAR A CLOGGED DISCHARGE CHUTE



WARNING: Hand contact with the rotating impeller inside the discharge chute is the most common cause of injury associated with snow blowers. **NEVER USE YOUR HAND TO CLEAN OUT THE DISCHARGE CHUTE.**

To Clear The Chute:

- **SHUT OFF THE ENGINE!**
- Wait 10 seconds to be sure that the impeller blades have stopped rotating.
- Always use a clean-out tool, not your hands.

A clean-out tool is attached to either the handle or the top of the auger housing (see Figure 23). Use the clean-out tool to remove snow from the auger housing.

How To Use The Clean-Out Tool

- Release the auger drive lever.
- Pull out the safety key.
- Disconnect spark plug wire.
- Do not place your hands in the auger or discharge chute. Use a clean-out tool to remove snow or debris.



WARNING: Blockage must be cleared only after shutting off the snow blower and only with a clean-out tool, not by hand.

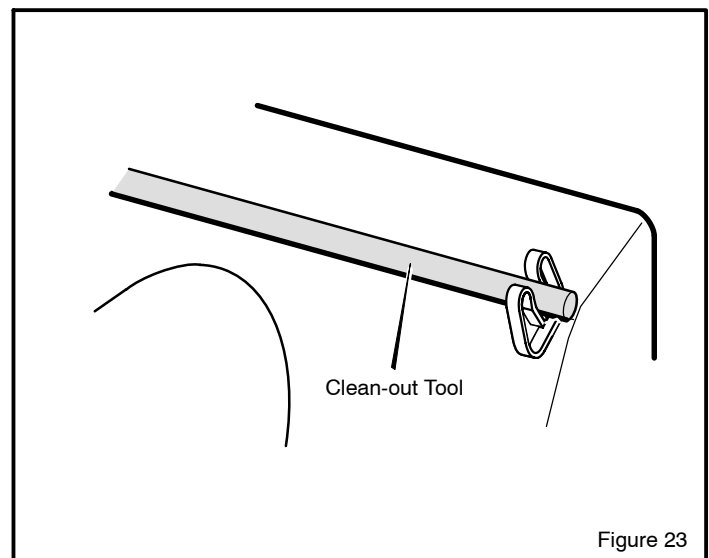

Figure 23

OPERATION

OPERATING TIPS

1. For optimum snow blower efficiency, adjust ground speed, not the throttle. REMEMBER – if the wheels slip, forward speed will be reduced. The engine is designed to deliver optimum performance at full throttle and must be run at this power setting at all times.
2. Most efficient snowblowing is accomplished when snow is removed immediately after it falls.
3. For complete snow removal, slightly overlap each swath previously taken.
4. Snow should be discharged downwind whenever possible.
5. For normal usage, set the skids one–eighth inch (3 mm) below the scraper bar. For extremely hard–packed snow surfaces, the skids may be adjusted upward to insure cleaning efficiency.
6. On gravel or crushed rock surfaces, the skids should be set at 1–1/4 inch (32 mm) below the scraper bar (see To Adjust Skid Height, in the Adjustment/Repair section in this manual). Rocks and gravel must not be picked up and thrown by the machine.
7. After the snowblowing job has been completed, allow the engine to idle for a few minutes, to melt snow and ice accumulated on the engine.
8. Clean the snow thrower thoroughly after each use.
9. Remove ice and snow accumulation and all debris from the entire snow thrower, and flush with water (if possible) to remove all salt or other chemicals. Wipe snow thrower dry.
10. Before starting snow blower, always inspect augers and impeller for ice accumulation and/or debris, which could result in snow blower damage.
11. Check oil level before every start. Make sure the oil is at the FULL mark on the oil fill cap/dipstick.

SERVICE RECOMMENDATIONS

SERVICE RECOMMENDATIONS									
PROCEDURE		FIRST 2 HOUR	BEFORE EACH USE	OFTEN	EVERY 5 HOURS	EVERY 10 HOURS	EVERY 25 HOURS	BEGINNING EACH SEASON	BEFORE STORAGE
S N O W T H R O W E R	Tighten all screws and nuts	√		√				√	
	Check Traction Clutch Cable Adjustment (See Cable Adjustment)	√						√	
	Check Auger Clutch Cable Adjustment (See Cable Adjustment)	√						√	
	Adjust Drive Belts	√					√	√	
	Lubricate Chains and Hex Shaft							√	√
	Lubricate Auger Shaft (See Shear Bolt Replacement)					√			√
E N G I N E	Oil, Check		√		√			√	
	Oil, Change	√					√	√	

The warranty on this snowthrower does not cover items that have been subjected to operator abuse or negligence. To receive full value from the warranty, operator must maintain snowthrower as instructed in this manual. The following **Service Recommendations** is supplied to assist operator to properly maintain snowthrower. This is a check list only. Adjustment referred to will be found in the MAINTENANCE section of this manual.

AFTER EACH USE

1. Check for any loose or damaged parts.
2. Tighten any loose fasteners.
3. Check and maintain the auger.
4. After each use, remove all snow and slush off the snowthrower to prevent freezing of auger or controls.
5. Check controls to make sure they are functioning properly.
6. If any parts are worn or damaged, replace immediately.

MAINTENANCE

Some adjustments will need to be made periodically to properly maintain your snowthrower.

All adjustments in the MAINTENANCE section of this manual should be checked at least once each season.

SNOWTHROWER

The following adjustment should be performed more than once each season.

Auger and Traction Drive Belts should be adjusted after the first 2 to 4 hours of use, again about mid-season and twice each season thereafter (See To Adjust Belts paragraph in the MAINTENANCE section).

AS REQUIRED

Auger Gear Box

The auger gear box is lubricated at the factory and should not require additional lubrication.

If for some reason the lubricant should leak out, or if the auger gear box has been serviced, add Lubriplate GR132 Grease or "Deere Multi-Purpose Lithium Grease". Maximum 3-1/4 ounces, (92 grams) should be used.

Remove filler plug D (Figure 24 and Figure 25), once a year. If grease is visible, do not add. If grease is not visible, use a piece of fine wire, like a dipstick to check if there is grease in the gear box. Mobilux EP1 and Shell Aldania EP1 are suitable equivalents.

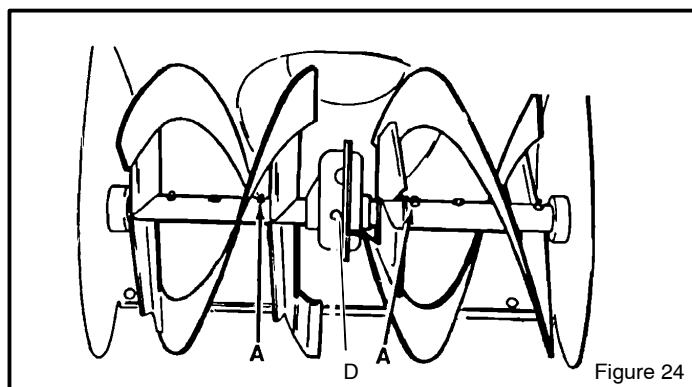

Figure 24

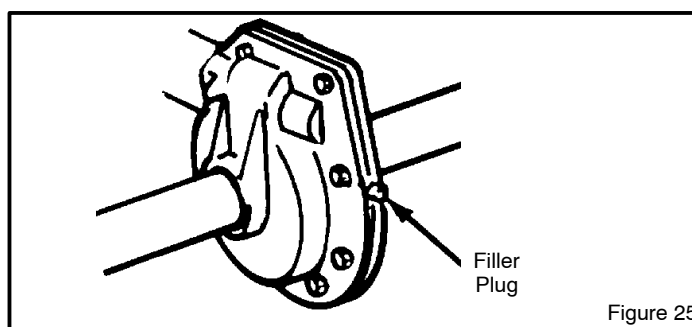

Figure 25

LUBRICATION

Bearings and bushings

All bearings and bushings are lifetime lubricated and require no maintenance.

Hex shaft and chains

For storage, the hex shaft should be wiped with a cloth lightly moistened with motor oil to prevent rusting (see Figure 27).

For storage, the chains should be lubricated with a chain type lube. (see Figure 27).

NOTE: Any greasing or oiling of the above mentioned components can cause contamination of the rubber friction wheel. If the disc drive plate or friction wheel come in contact with grease or oil damage to rubber friction wheel will result .

If grease or oil comes into contact with the disc drive plate or friction wheel, make sure to clean plate and wheel thoroughly with an alcohol base solvent.

LUBRICATION – EVERY 10 HOURS

1. **Auger Shaft** – Using a hand grease gun, lubricate the auger shaft zerk fittings (A) every ten (10) operating hours. Each time a shear bolt is replaced, the auger shaft **MUST** be greased (Figure 24). (See To Replace Auger Shear Bolt in the MAINTENANCE section).
2. For storage or when replacing shear bolts, remove shear bolts and lubricate auger shaft zerks. Rotate augers several times on the shaft and reinstall the shear bolts.

MAINTENANCE

LUBRICATION – EVERY 25 HOURS

Chute Rotation Gear

Lubricate the **chute rotation gear** with automotive type oil. (see Figure 26).

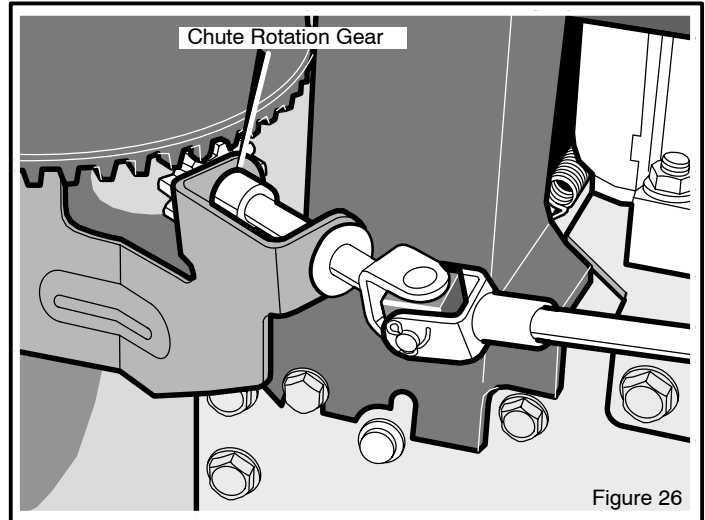

Chains

1. Position speed selector lever in first (1) forward gear.
2. Stand the snowthrower up on the auger housing end.

NOTE: When the crank case is filled with oil, do not leave the snowthrower standing up on the auger housing for an extended period of time.

3. Remove the bottom panel.

4. Lubricate the **chains** with a chain type lubricant.
5. Wipe the **hexshaft and sprockets** with 5W30 motor oil.
NOTE: Clean all excess grease or oil found on the rubber friction wheel or the disc drive plate.
CAUTION: Do not allow grease or oil to contact the rubber friction wheel or the disc drive plate.
6. Install the bottom panel.

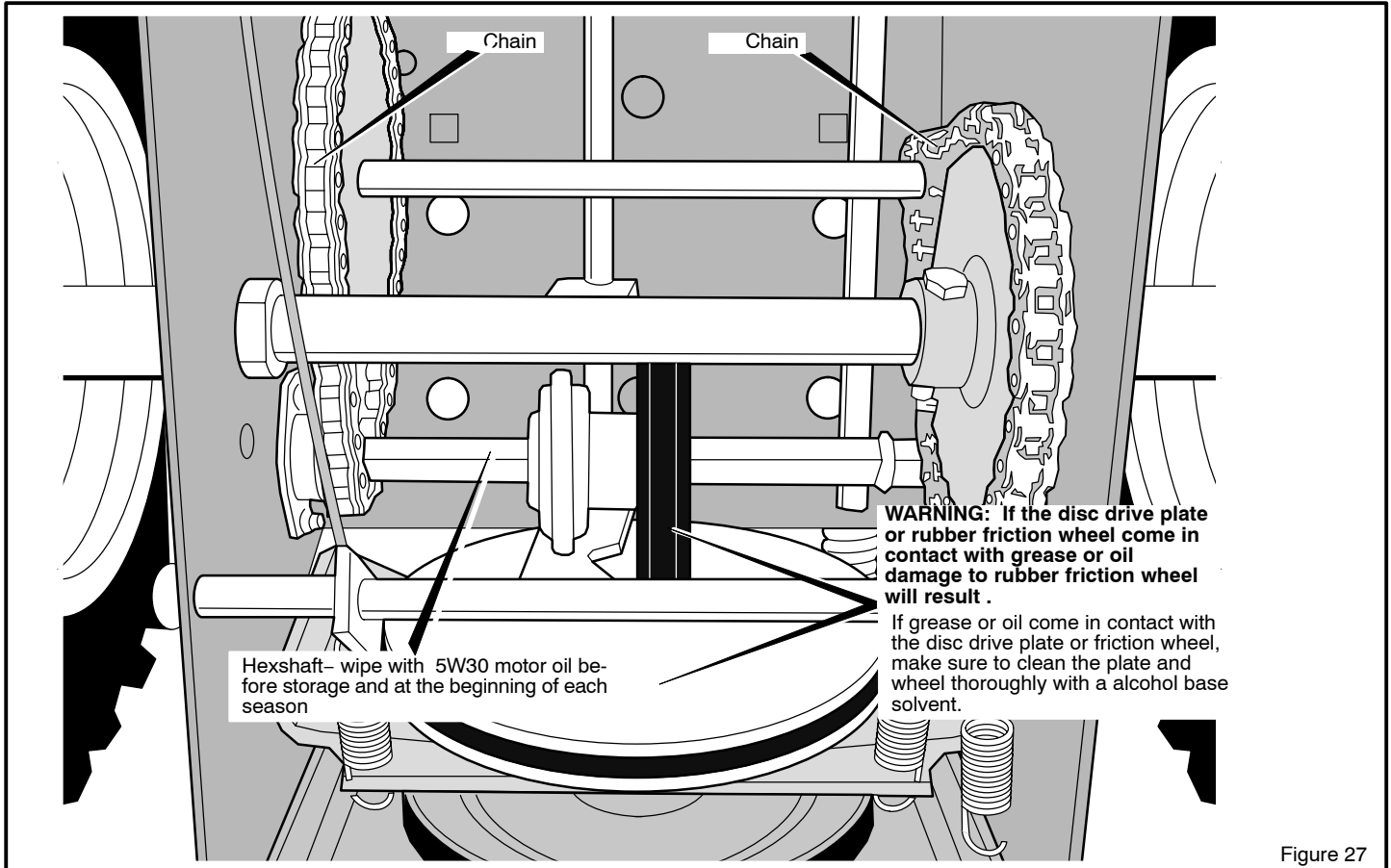

MAINTENANCE

ENGINE

Check Crankcase Oil Level before starting engine and after each 5 hours of continuous use (see Figure 28). Add proper motor oil as required.

NOTE: Overfilling the engine can affect performance. Tighten the oil fill cap securely to prevent leakage.

Change Oil every 25 hours of operation or at least once a year, even if the snowthrower is not used for twenty-five hours. Use a clean, high quality detergent oil. Fill the crank case to FULL line on dipstick (see Figure 28). Be sure original container is marked: A.P.I. service "SF" or higher. Do not use SAE10W40 oil (as it may not provide proper lubrication). See Chart for oil recommendations.

To Drain Oil – Position snowthrower so that the oil drain plug is lowest point on engine. Remove oil drain plug and oil fill cap and drain oil into a suitable container (Figure 29).

NOTE: Oil will drain more freely when warm.

Replace oil drain plug and tighten securely. Refill crank case with proper motor oil or as indicated in the preceding paragraphs of this section.

TEMPERATURE	TYPE OF OIL
0°F (-18° C) and above	S.A.E. 5W30
0°F (-18° C) and below	synthetic 0W30

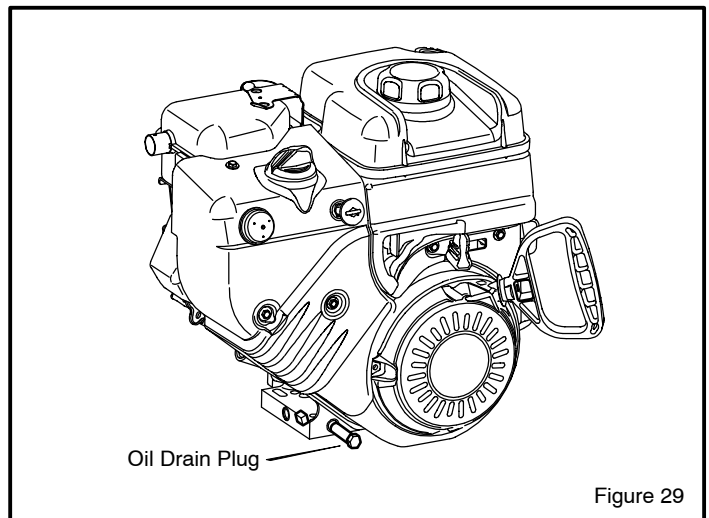
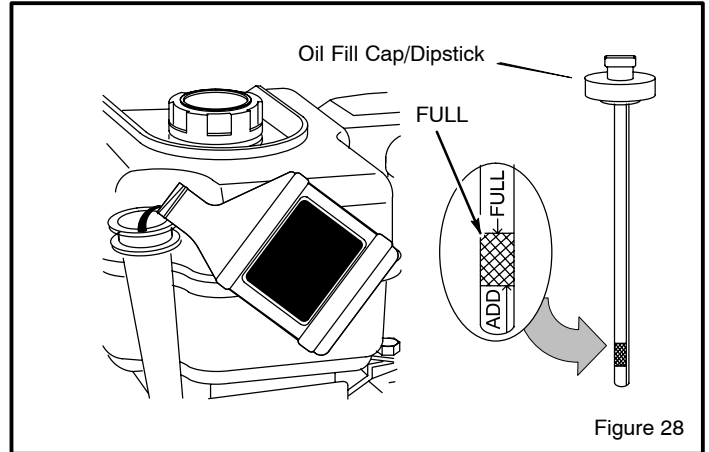
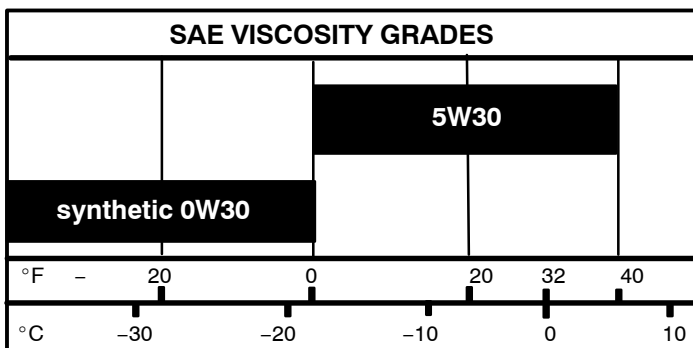

MAINTENANCE



WARNING: Always turn unit off, remove ignition key and disconnect the spark plug wire before making any repairs or adjustments.

AUGER HOUSING HEIGHT ADJUSTMENT

TO ADJUST SCRAPER BAR

After considerable use, the metal scraper bar will have a definite wear pattern. The scraper bar in conjunction with the skids should always be adjusted to allow one-eighth of an inch (3 mm) between the scraper bar and the sidewalk or area to be cleaned.

To adjust the scraper bar, proceed as follows:

1. Position the snowthrower on a level surface.
2. Loosen the carriage bolts and nuts securing the scraper bar to the auger housing.
3. Adjust the scraper bar to the proper position. Tighten the carriage bolts and nuts, insuring that the scraper bar is parallel with the working surface.
4. For extended operation, the scraper bar may be reversed. If the scraper bar must be replaced because of wear, remove the carriage bolts and nuts and install a new scraper bar.

TO ADJUST SKID HEIGHT

This snowthrower is equipped with two height adjust skids, secured to the outside of the auger housing. These elevate the front of the snowthrower.

When removing snow from a hard surface area such as a paved driveway or walk, adjust the skids up to bring the front of the snowthrower down.

When removing snow from rock or uneven construction, raise the front of the snowthrower by moving the skids down. This will help to prevent rocks and other debris from being picked up and thrown by the augers.

To adjust skids, proceed as follows:

1. Place a block (equal to height from ground desired) under scraper bar near but not under skid.
2. Loosen skid mounting nuts (Figure 30) and push the skid down until it touches the ground. Retighten mounting nuts.
3. Set skid on other side at same height.

NOTE: Make sure that snowthrower is set at same height on both sides.



WARNING: Be certain to maintain proper ground clearance for your particular area to be cleared. Objects such as gravel, rocks or other debris, if struck by the impeller, may be thrown with sufficient force to cause personal injury, property damage or damage to the snowthrower.

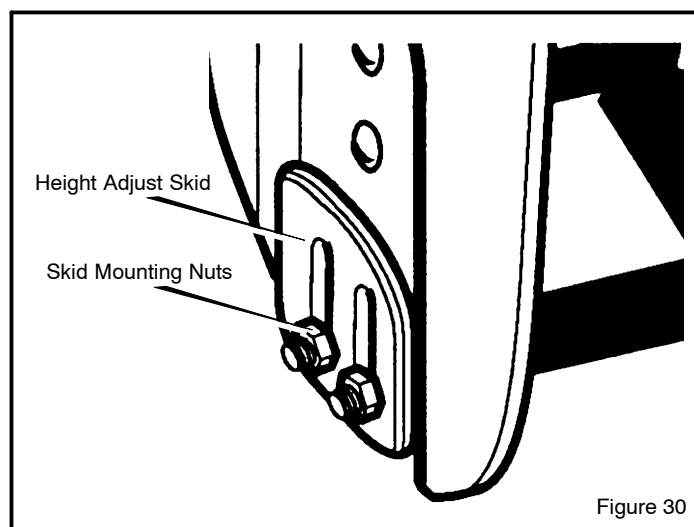

Figure 30

MAINTENANCE

BELT ADJUSTMENT

Traction Drive Belt

The traction drive belt has constant spring pressure and does not require an adjustment. If the traction drive belt is slipping, replace the belt. See "How To Replace The Belts" in the Maintenance section.

Auger Drive Belt

If your snowthrower will not discharge snow, check the control cable adjustment. If it is correct, then check the condition of the auger drive belt. If it is damaged or loose, replace it (see Belt Replacement in this section of the manual).

1. Disconnect spark plug wire.
2. Remove **screw** from **belt cover**. Remove **belt cover** (see Figure 31).
3. Loosen nut on auger idler pulley and move auger idler pulley towards belt about 1/8 inch (3 mm) (see Figure 35).
4. Tighten nut.
5. Have someone engage auger drive clutch. Check tension on belt (opposite idler pulley). Belt should deflect about 1/2 inch (12.5 mm) with moderate pressure (Figure 32). You may have to move idler pulley more than once to obtain the correct tension.
6. Reinstall belt cover.
7. Whenever belts are adjusted or replaced, the cables will need to be adjusted. (See Cable Adjustment in this section of the manual).
8. Attach the spark plug wire.

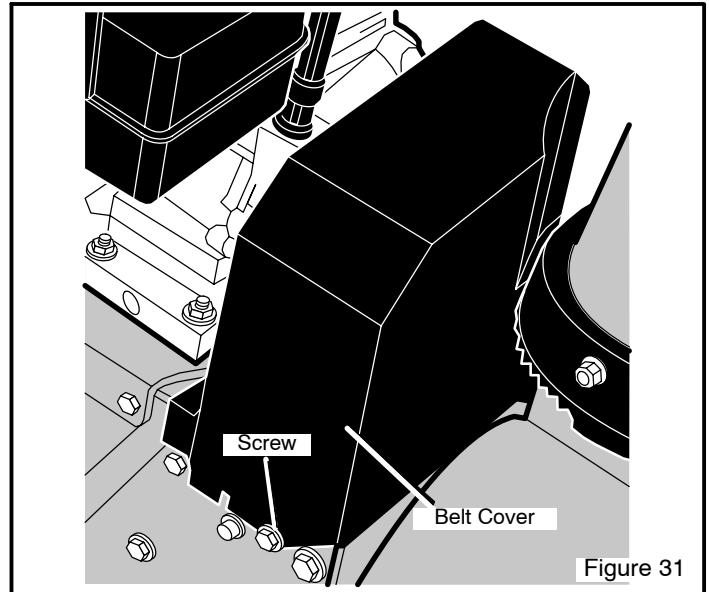

Figure 31

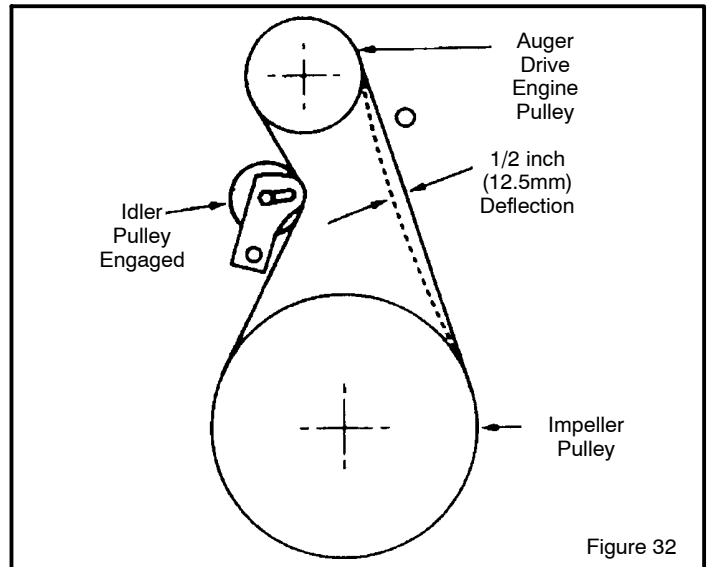

Figure 32

MAINTENANCE

HOW TO REPLACE THE BELTS

The drive belts are of special construction and must be replaced with original factory replacement belts available from your nearest authorized service center.

Some steps require the assistance of a second person.

How To Remove the Auger Drive Belt

If the auger drive belt is damaged, the snow thrower will not discharge snow. Replace the damaged belt as follows.

1. Disconnect the spark plug wire.
2. Loosen the **bolts** on each side of the **bottom panel** (see Figure 33).
3. Remove the **bottom panel**.
4. Remove **screw** from **belt cover**. Remove the **belt cover** (see Figure 31).
5. Loosen the **belt guide**. Pull the **belt guide** away from the **auger drive pulley** (see Figure 35).
6. Pull the **idler pulley** away from the **auger drive belt** and slip the **auger drive belt** off of the **idler pulley**.
7. Remove the **auger drive belt** from the **engine pulley**. To remove the **auger drive belt**, the **engine pulley** may have to be partially rotated.
8. Remove the top four **bolts** that hold together the **auger housing** and the **motor box**. Loosen the bottom two **bolts**. The **auger housing** and the **motor box** can now be split apart for removal of the belt (see Figure 34).
9. Remove the old **auger drive belt** from the **auger drive pulley**. Replace the **auger drive belt** with an original factory replacement belt available from an authorized service center (see Figure 35).
10. Install the new **auger drive belt** onto the **auger drive pulley**.
NOTE: To assemble the auger housing to the motor box, have someone hold the auger clutch lever in the ENGAGED position. This will move the idler arm and pulley enough to allow the auger drive pulley to move back into position.
11. Assemble the **auger housing** to the **motor box** with the four **bolts** that were removed in step 8. Tighten the bottom two **bolts**.
12. Install the **auger drive belt** onto the **engine pulley**.
13. Slip the **auger drive belt** under the **idler pulley**.
14. Adjust the **auger drive belt**. See "How To Adjust The Auger Drive Belt" in the Maintenance section.
15. Adjust the **belt guide**. See "How To Adjust The Belt Guide" in the Maintenance section.

16. Install the **belt cover**. Tighten **screw** (See Figure 31).
17. Check the adjustment of the cables. See "How To Check And Adjust The Cables" in the Maintenance section.
18. Install the **bottom panel** (see Figure 33).
19. Tighten the **bolts** on each side of the **bottom panel**.
20. Connect the spark plug wire.

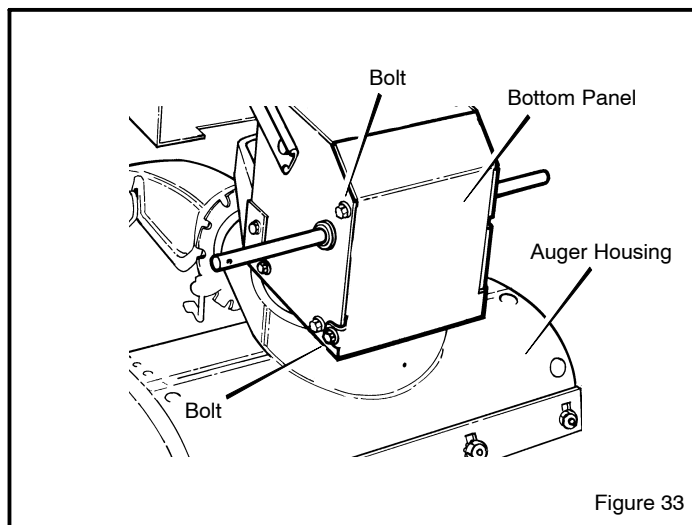

Figure 33

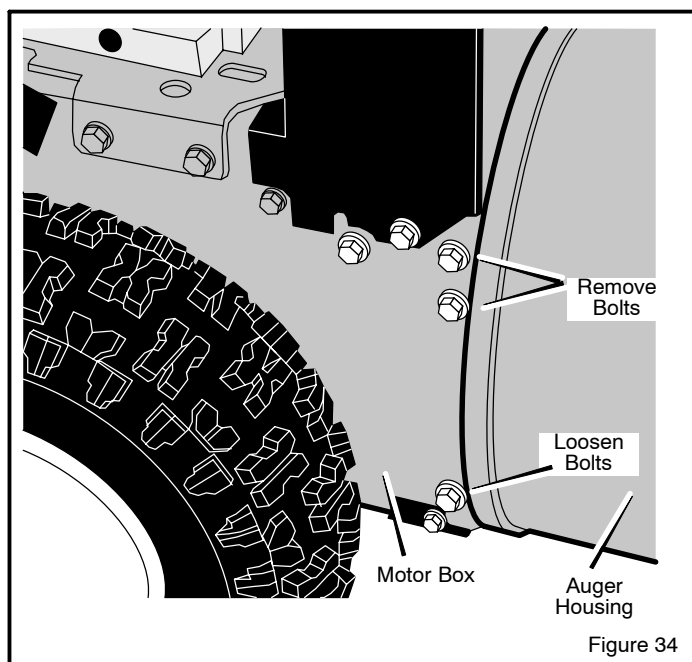

Figure 34

MAINTENANCE

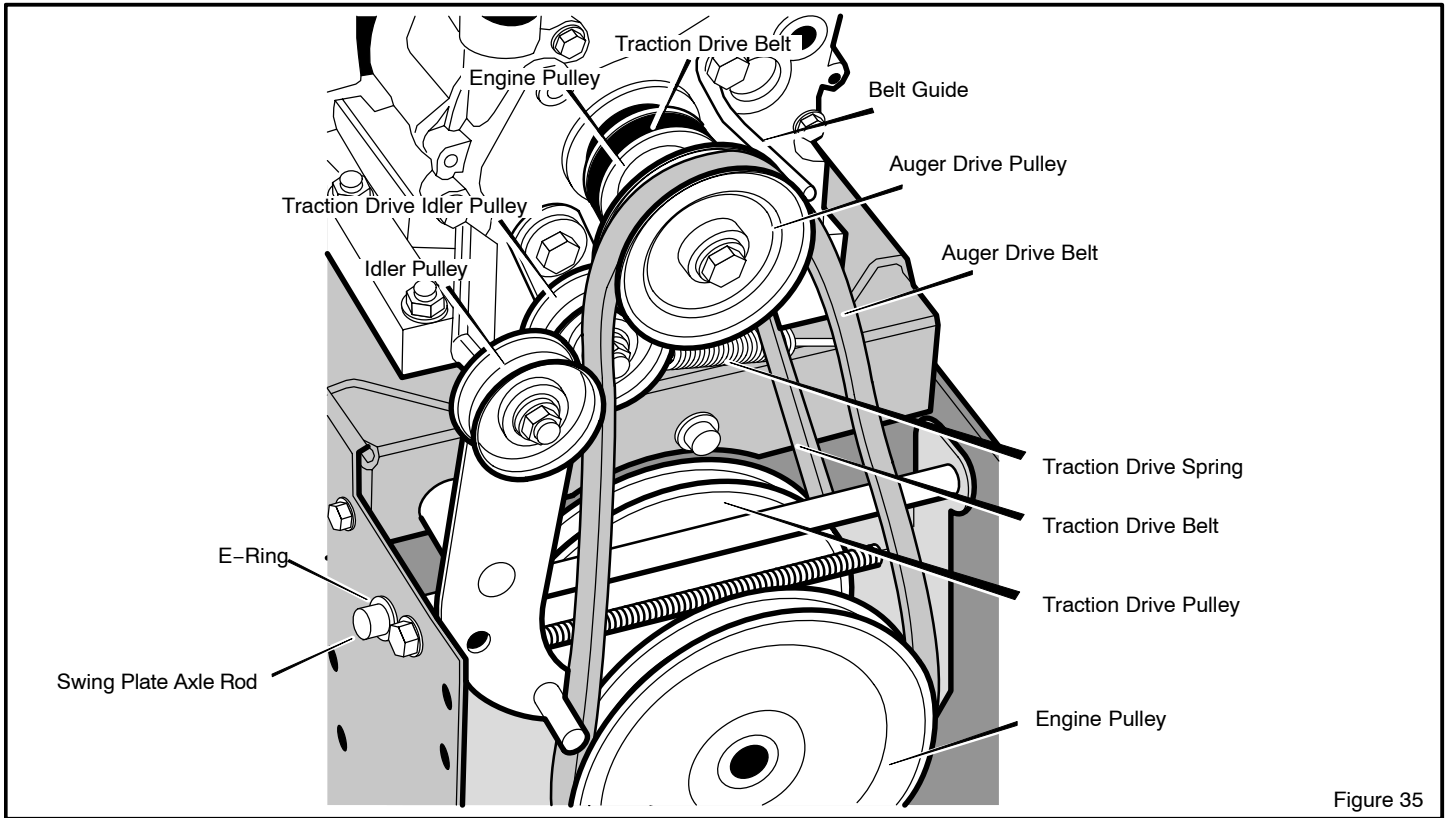

Figure 35

MAINTENANCE

How To Remove the Traction Drive Belt

If the snow thrower will not move forward, check the traction drive belt for wear or damage. If the traction drive belt is worn or damaged, replace the belt as follows.

1. Disconnect the spark plug wire.
2. Remove the auger drive belt. See “How To Remove The Auger Drive Belt” in the Maintenance section.
3. Remove the **e-ring** from one end of the **swing plate axle rod**. Remove the **swing plate axle rod** to allow the swing plate to pivot forward (see Figure 35).
4. Remove the **traction drive spring**.
5. Remove the old **traction drive belt** from the **traction drive pulley** and from the **engine pulley**. Replace the **traction drive belt** with an original factory replacement belt available from an authorized service center.
6. Install the new **traction drive belt** onto the **traction drive pulley** and onto **engine pulley**.
7. Make sure the **traction drive idler pulley** is properly aligned with the **traction drive belt**.
8. Attach the **traction drive spring**.
9. Install the **swing plate axle rod** and secure with the **e-ring** removed earlier.
10. The bottom of the **swing plate** must be positioned between the **alignment tabs**. Make sure the **swing plate** is properly secured (see Figure 36).
11. Install and adjust the **auger drive belt**. See “How To Remove The Auger Drive Belt” in the Maintenance section.
12. Adjust the **belt guide**. See “How To Adjust The Belt Guide” in the Maintenance section.
13. Install the **bottom panel** (see Figure 33).
14. Tighten the **bolts** on each side of the **bottom panel**.
15. Install the **belt cover**. Tighten **screw** (see Figure 31).
16. Check the adjustment of the cables. See “How To Check And Adjust The Cables” in the Maintenance section.
17. Connect the spark plug wire.

NOTE: If the drive will not engage after the traction drive belt has been replaced, then check to make sure that the swing plate is positioned between the alignment tabs.

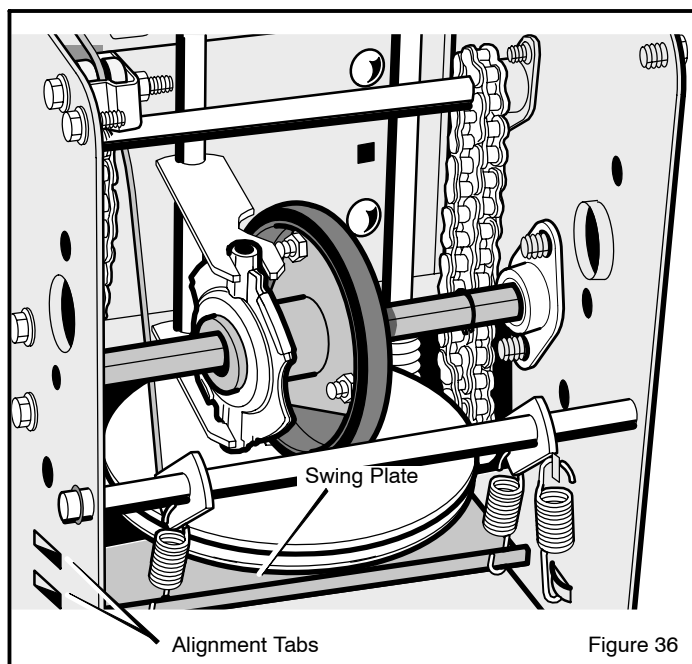

Figure 36

MAINTENANCE

BELT GUIDE ADJUSTMENT

1. Remove spark plug wire.
2. Have someone engage auger drive.
3. Measure the distance between the belt guide and belt. The distance should be 1/8 inch (3.175 mm) for guide. See Figure 37.
4. If adjustment is necessary, loosen belt guide mounting bolt. Move belt guide to the correct position. Tighten mounting bolt.
5. Reinstall belt cover.
6. Reconnect spark plug wire.

HOW TO CHECK AND ADJUST THE CABLES

The cables are adjusted at the factory and no adjustment should be necessary. If the cables have become stretched or are sagging adjustment will be necessary.

Whenever belts are adjusted or replaced, the cables will need to be adjusted.

1. Move clutch lever to the full forward position (just contacting plastic bumper). Holding cable tight, note position of fitting to hole in clutch lever.
2. The center of the "Z" fitting should be between the centre and top of the hole in the clutch lever. Adjust either the auger drive cable or the traction drive cable as follows.

Auger Drive Cable Adjustment



WARNING: Drain the gasoline outdoors, away from fire or flame.

1. Remove the gas from the gas tank. Stand the snow thrower up on the front end of the auger housing.
2. Push cable through spring to expose the threaded portion of the cable (see Figure 38).
3. Hold square end of threaded portion with pliers and adjust locknut in or out until correct adjustment is reached. Pull cable back through spring and connect cable.

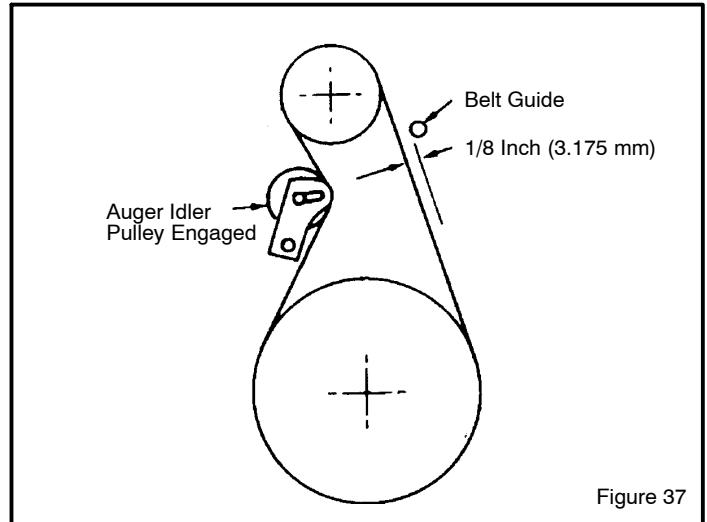

Figure 37

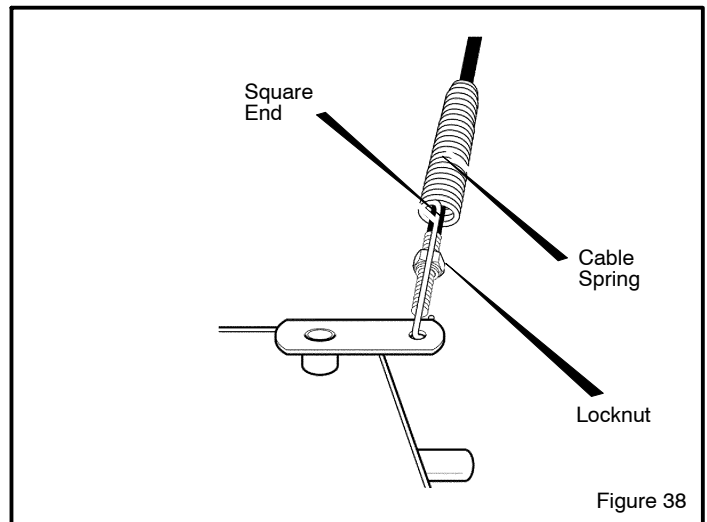

Figure 38

MAINTENANCE

Traction Drive Cable Adjustment



WARNING: Drain the gasoline outdoors, away from fire or flame.

1. Remove the gas from the gas tank. Stand the snow thrower up on the front end of the auger housing.
2. Loosen the **bolts** on each side of the **bottom panel** (see Figure 39).
3. Remove the **bottom panel**.
4. Slide the **cable boot** off the **cable adjustment bracket** (see Figure 40).
5. Push the bottom of the **traction drive cable** through the **cable adjustment bracket** until the “**Z**” hook can be removed.
6. Remove the “**Z**” hook from the **cable adjustment bracket**. Move the “**Z**” hook down to the next adjustment hole.
7. Pull the **traction drive cable** up through the **cable adjustment bracket**.
8. Put the **cable boot** over the **cable adjustment bracket**.
9. To check the adjustment, depress the drive lever and check the length of the **drive spring** (see Figure 41). In correct adjustment, the length of the **drive spring** is minimum 3 inches (76 mm.) maximum 3-3/8 inches (85 mm.).
10. Install the **bottom panel** (see Figure 39).
11. Tighten the **bolts** on each side of the **bottom panel**.

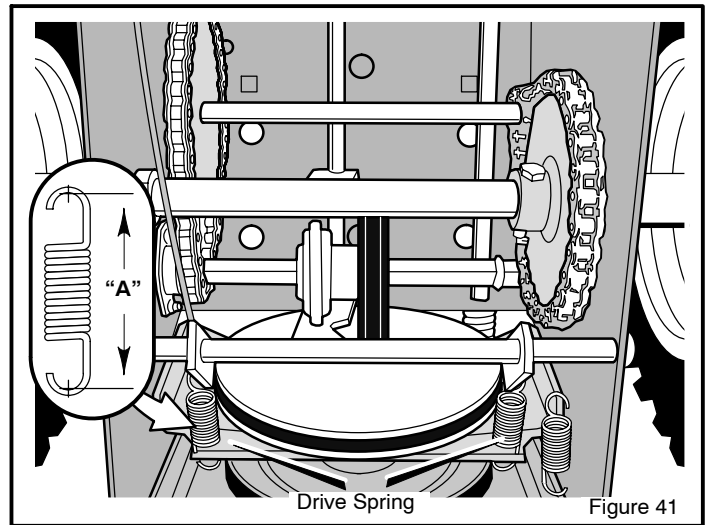
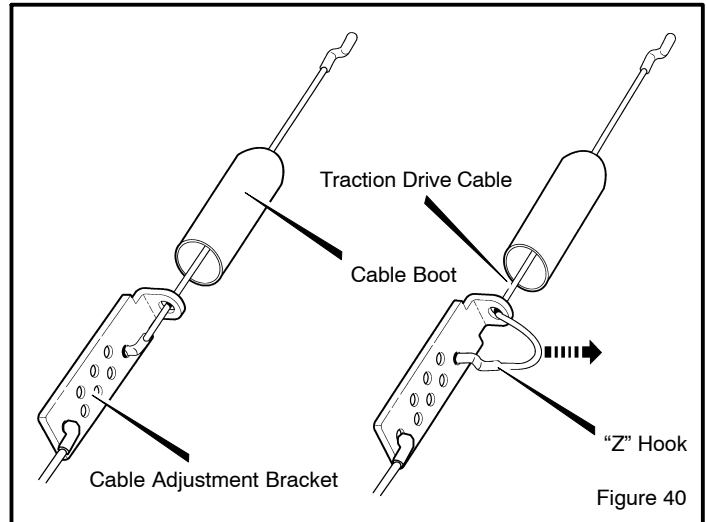
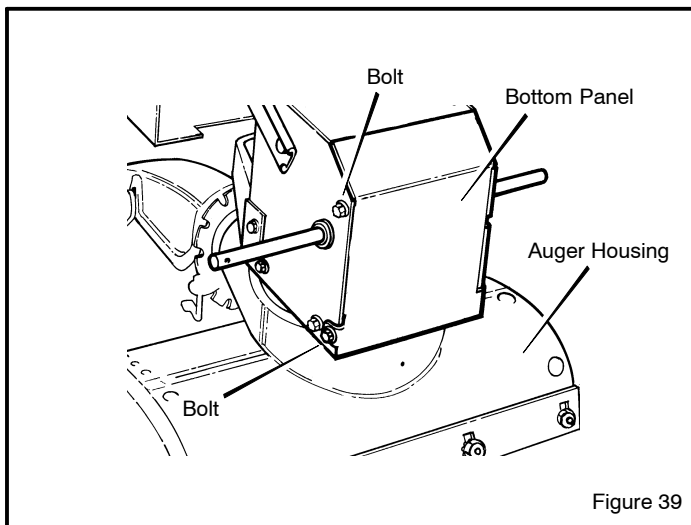

MAINTENANCE

HOW TO ADJUST OR REPLACE THE FRICTION WHEEL

How To Check The Friction Wheel

If the snow thrower will not move forward, check the traction drive belt, the traction drive cable or the friction wheel. If the friction wheel is worn or damaged, it must be replaced. See "How To Replace the Friction Wheel" in this section. If the friction wheel is not worn or damaged, check as follows.

1. Remove the gas from the gas tank. Stand the snow thrower up on the front end of the **auger housing** (see Figure 42).



WARNING: Drain the gasoline outdoors, away from fire or flame.

2. Disconnect the spark plug wire.
3. Loosen the **bolts** on each side of the **bottom panel** (see Figure 42).
4. Remove the **bottom panel**.
5. Position the **shift speed lever** in the lowest forward speed.
6. Note the position of the **friction wheel** (see Figure 43). The correct distance "**A**" from the right side of the **friction wheel** to the outside of the motorbox is as follows:

Tire Size	Distance "A"
12 and 13 inch	4-1/8" (10.5 cm.)
16 inch	4-5/16" (10.95 cm.)

If the **friction wheel** is not in the correct position, adjust as follows.

How To Adjust The Friction Wheel

1. Position the **shift speed lever** in the lowest forward speed.
2. Loosen hex **jam nut** on **speed select rod**. Remove **ball joint** from **shifter rod** (see Figure 44).
3. Move the **friction wheel** to the correct position (see Figure 43).
4. Turn the **adaptor** until the **ball joint** is aligned with the mounting hole in the **shifter rod** (see Figure 44). When aligned, attach the **ball joint** to the **shifter rod**.

5. Tighten the **jam nut**.
6. Install the **bottom panel** (see Figure 42).
7. Tighten the **bolts** on each side of the **bottom panel**.

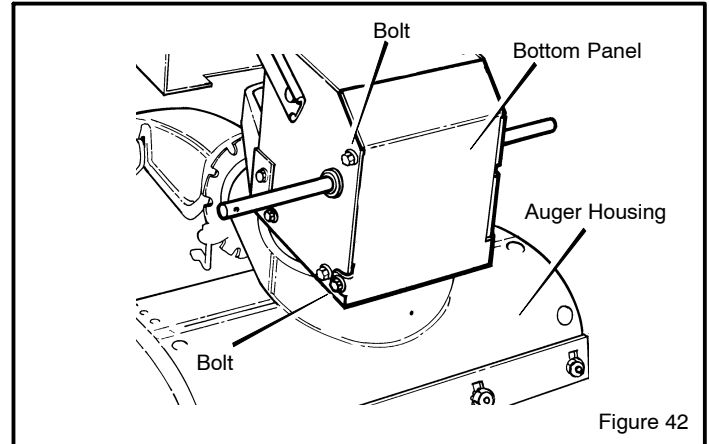

Figure 42

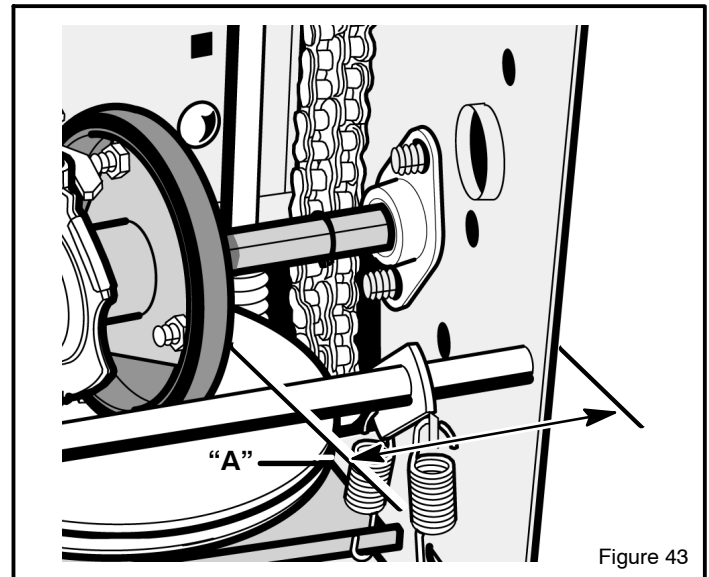

Figure 43

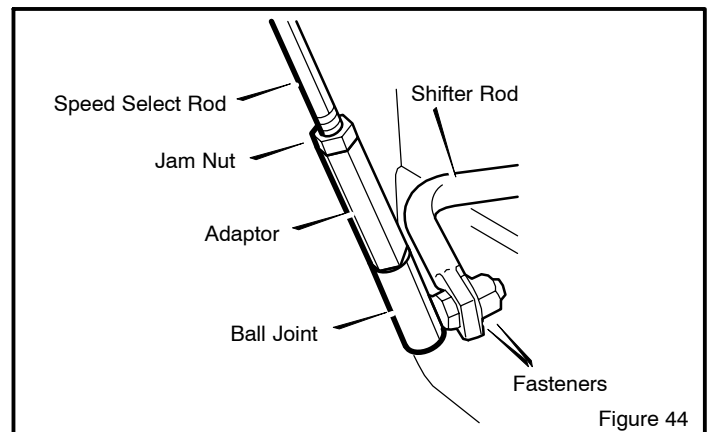

Figure 44

MAINTENANCE

How To Replace The Friction Wheel

If the friction wheel is worn or damaged, the snow thrower will not move forward. The friction wheel must be replaced as follows.

1. Remove the gas from the gas tank. Stand the snow thrower up on the front end of the **auger housing (4)**. (see Figure 42).



WARNING: Drain the gasoline outdoors, away from fire or flame.

2. Disconnect the spark plug wire.
3. Remove the fasteners that secure the left **wheel**. Remove the **left wheel** from the **axle** (see Figure 45)
4. Loosen the **bolts** on each side of the **bottom panel**.
5. Remove the **bottom panel**.

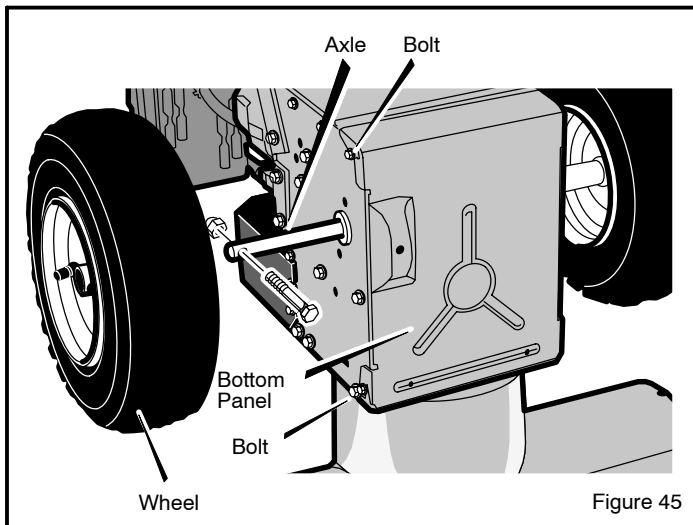

6. Remove the fasteners that secure the **drive sprocket** to the **axle** (see Figure 46).
7. Remove the right wheel, **axle**, and **drive sprocket**.

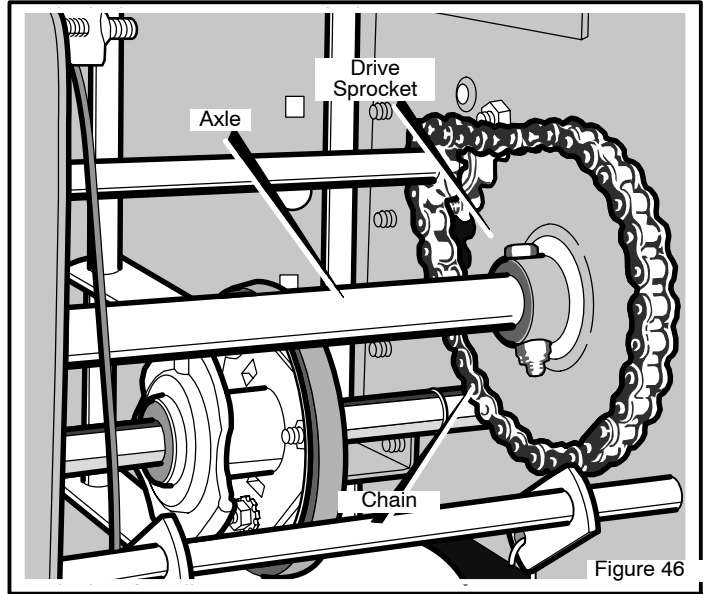

Figure 46

8. Remove the four **bolts** that hold the **bearings** on each side of the **hex shaft** (see Figure 47).
9. Remove the **hex shaft** and **bearings**.

NOTE: Take special note of the position of the washers on the hex shaft.

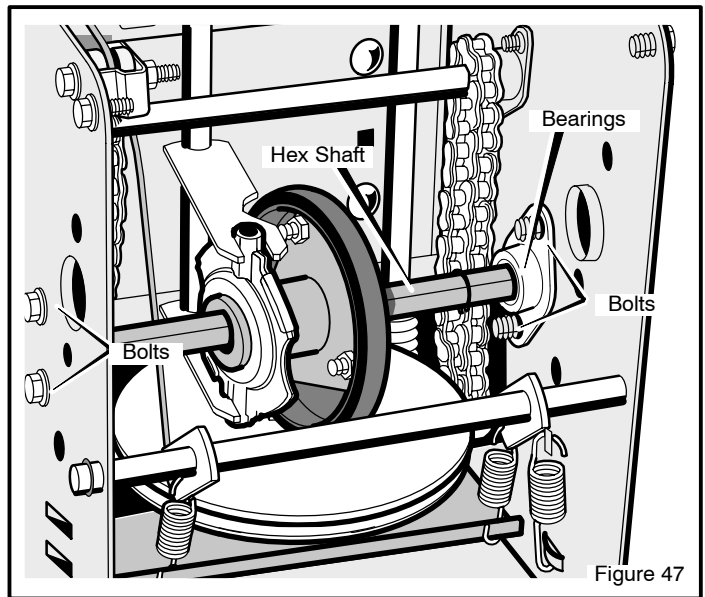
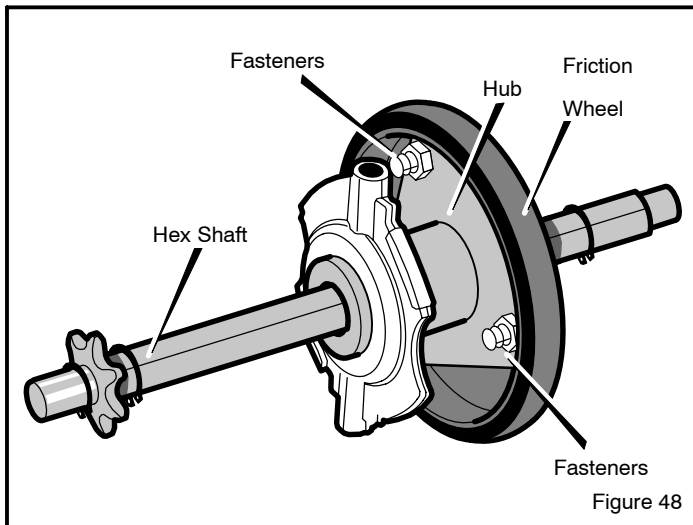

Figure 47

MAINTENANCE

10. Remove the three **fasteners** that hold the **friction wheel** to the **hub** (see Figure 48).
11. Remove the **friction wheel** from the **hub**. Slip the **friction wheel** off the **hex shaft**.
12. Assemble the new **friction wheel** onto **hub** with the fasteners removed earlier.



13. Install the **hex shaft** and **bearings** with the four bolts removed earlier (see Figure 49).

Make sure the washers are properly installed in the original position. Also, make sure the two washers are properly aligned with the actuator arms.

14. Make sure the **hex shaft** turns freely.

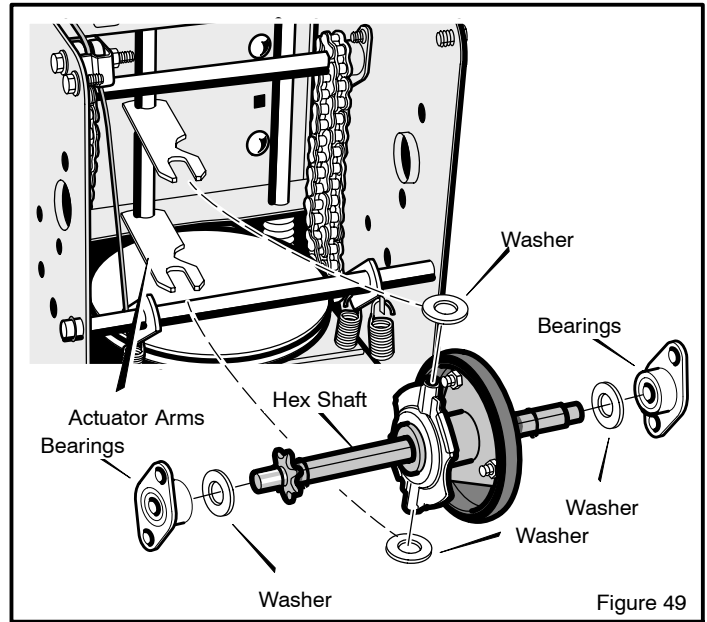

15. Install the right wheel, **axle**, and **drive sprocket** with the fasteners removed earlier. Install the **chain** onto the **drive sprocket** (see Figure 46).
16. Check the adjustment of the friction wheel. See "How To Adjust The Friction Wheel" in this section.
17. Make sure the friction wheel and the disc drive plate are free from grease or oil.
18. Install the **bottom panel** (see Figure 45).
19. Tighten the **bolts** on each side of the **bottom panel**.
20. Install the **left wheel** to the **axle** with the fasteners removed earlier.
21. Connect the spark plug wire.

MAINTENANCE

HOW TO REMOVE THE SNOW HOOD

To access the spark plug, the snow hood must be removed as follows:

1. Remove the choke control knob (see Figure 50).
2. Remove the ON/OFF key.
3. Remove the four mounting screws.
4. Slowly remove the snow hood (see Figure 51). Make sure that the primer button hose and the ignition wire are not disconnected.
5. To install the snow hood, first make sure that the primer button hose and the ignition wire are connected.
6. Mount the snow hood to the engine and secure with the four mounting screws (see Figure 52).
7. Align the tab on the choke control knob with the slot in the snow hood (see Figure 53).
8. Connect the choke control knob with the choke shaft. Make sure the choke control knob is properly installed. If the choke control knob is not installed correctly, the choke will not operate.

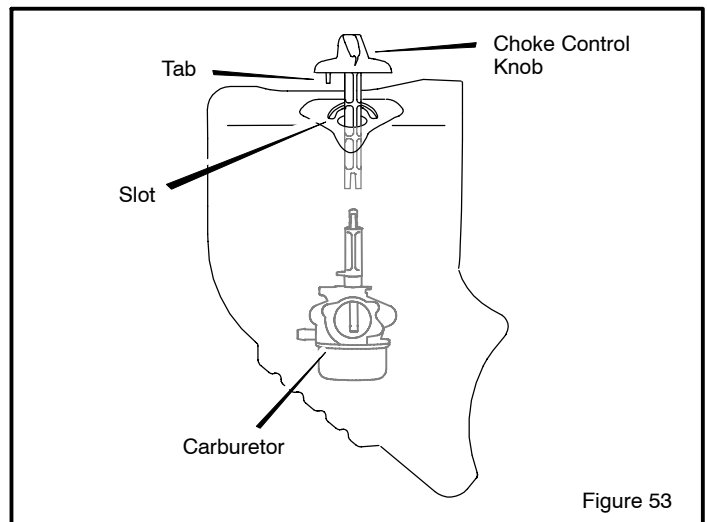
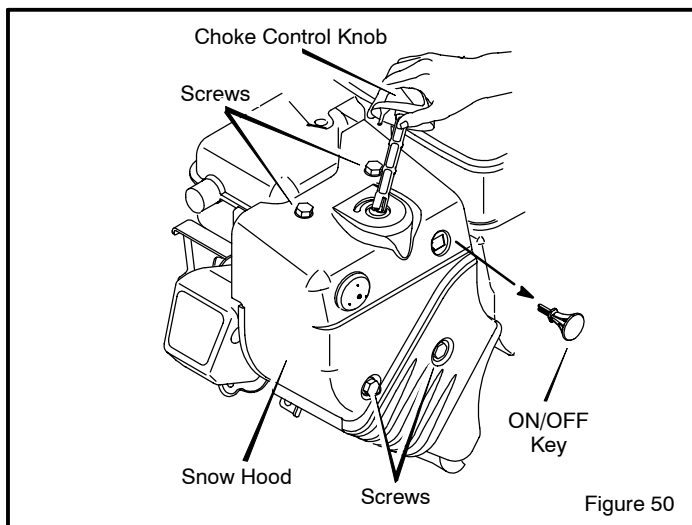
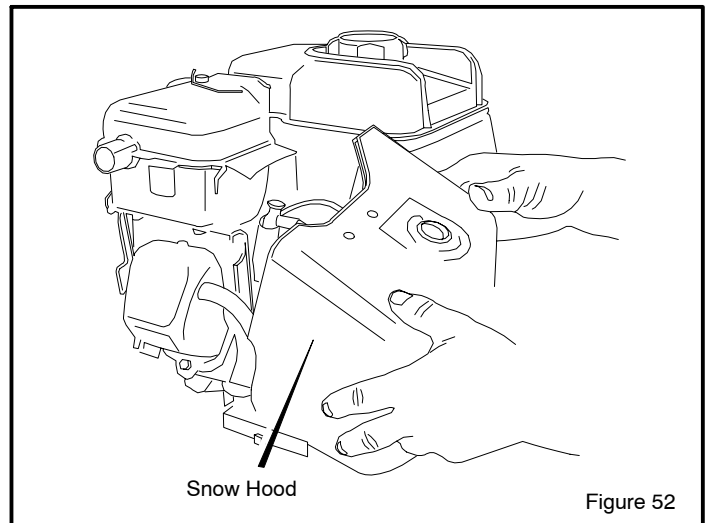
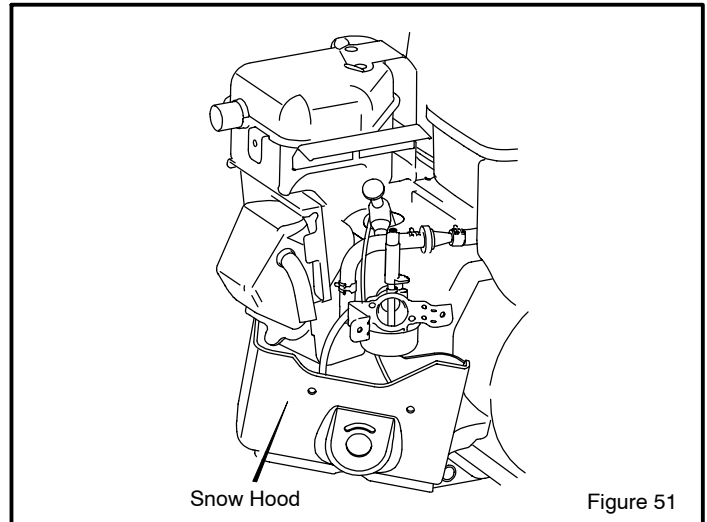

MAINTENANCE

AUGER SHEAR BOLT REPLACEMENT

The augers are secured to the auger shaft with special bolts that are designed to break if an object becomes lodged in the auger housing. Use of a harder bolt will reduce the protection provided by the shear bolt. To replace a broken shear bolt, proceed as follows:



WARNING: To insure safety and performance levels, only original replacement shear bolts should be used.

1. Move throttle to STOP, disengage all controls, disconnect the spark plug lead wire, and insure all moving parts have stopped.
2. Lubricate the auger shaft zerk fittings (see Lubrication Points in the Maintenance section of this manual).
3. Align the hole in the auger with the hole in the auger shaft. Install new shear bolt, spacer and locknut found in the toolbox located on the belt cover (See Figure 54).

NOTE: The spacer fits into the larger hole in the auger tube.

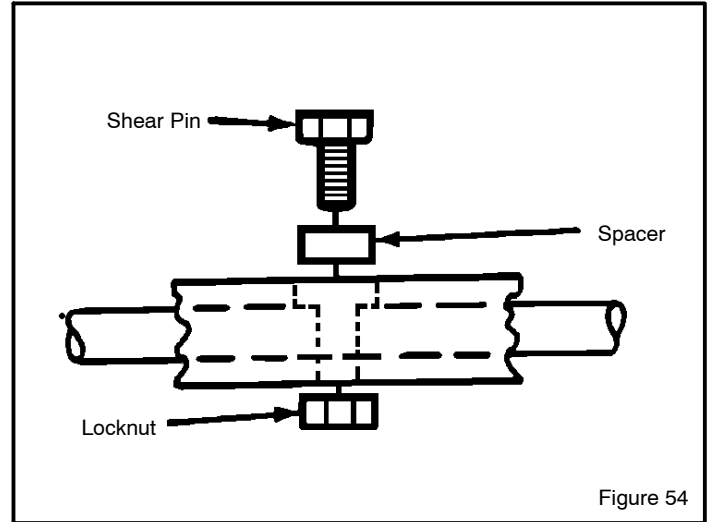

TO ADJUST OR REPLACE THE SPARK PLUG

Check the **spark plug** every twenty-five (25) hours. Replace the **spark plug** if the electrodes are pitted or burned or if the porcelain is cracked.

1. Clean spark plug and reset gap periodically.
2. Clean area around spark plug base before removal, to prevent dirt from entering engine.
3. Replace spark plug if electrodes are pitted or burned or if porcelain is cracked.
4. Clean spark plug by carefully scraping electrodes (do not sandblast or use wire brush).
5. Be sure spark plug is clean and free of foreign material. Check electrodes gap with a wire feeler gauge and reset gap to 0.030" (0.76 mm) if necessary. If a new spark plug is needed, refer to Engine Repair Parts section of this manual for proper replacement spark plug.
6. Before installing spark plug, coat threads lightly with graphite grease to insure easy removal.

7. Tighten plug firmly into engine. If torque wrench is available, torque plug to 18–23 ft-lbs.

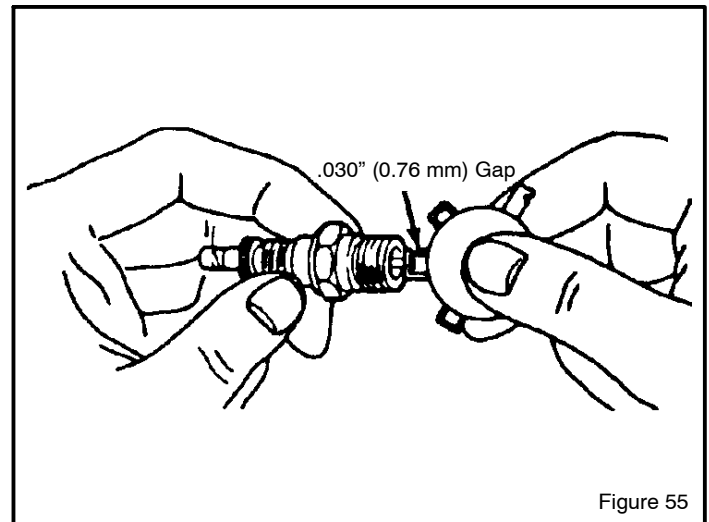

STORAGE

OFF SEASON STORAGE



WARNING: Never store the engine, with fuel in the tank, indoors or in a poor ventilated enclosure where fuel fumes could reach an open flame, spark or pilot light as on a furnace, water heater, clothes dryer, etc.

Handle gasoline carefully. It is highly flammable and careless use could result in serious fire damage to your person and /or property.

Drain fuel into approved containers outdoors, away from open flame.

If the snowthrower is to be stored for thirty (30) days or more at the end of the snow season, the following steps are recommended to prepare your snowthrower for storage.

NOTE: Gasoline must be removed or treated to prevent gum deposits from forming in the tank, filter, hose, and carburetor during storage.

1. To remove gasoline, run engine until tank is empty and engine stops.

If you do not want to remove the gasoline, add fuel stabilizer to any gasoline left in the tank to minimize gum deposits and acids. If the tank is almost empty, mix stabilizer with fresh gasoline in a separate container and add some to the tank. **ALWAYS FOLLOW INSTRUCTIONS ON STABILIZER CONTAINER. THEN RUN ENGINE AT LEAST 10 MINUTES AFTER STABILIZER IS ADDED TO ALLOW MIXTURE TO REACH CARBURETOR. STORE SNOWTHROWER IN SAFE PLACE.**

2. You can help keep your engine (4-cycles only) in good operating condition by changing oil before storage.
3. Lubricating the piston/cylinder area. This can be done by first removing the spark plug and squirting clean engine oil into the spark plug hole. Then cover the spark plug hole with a rag to absorb oil spray. Next, rotate the engine by pulling the starter two or three times. Finally, reinstall spark plug and attach spark plug wire.

4. Thoroughly clean the snowthrower.
5. Lubricate all lubrication points (see "Lubrication" in the Maintenance section).
6. Insure that all nuts, bolts, and screws are securely fastened. Inspect all visible moving parts for damage, breakage, and wear. Replace if necessary.
7. Touch up all rusted or chipped paint surfaces; sand lightly before painting.
8. Cover the bare metal parts of the blower housing auger, and the impeller with rust preventative.
9. If possible, store your snowthrower indoors and cover it to give protection from dust and dirt.
10. On models with folding handles, loosen the knobs that secure the upper handle. Rotate the upper handle back.
11. If the machine must be stored outdoors, block up the snowthrower and insure the entire machine is off the ground. Cover the snowthrower with a heavy tarpaulin.

REMOVING THE SNOWTHROWER FROM STORAGE

When removing the snowthrower from storage, follow the steps below.

1. Put the upper handle in the operating position, tighten the knobs that secure the upper handle.
2. Fill the fuel tank with a fresh fuel.
3. Check the spark plug. Make sure the gap is correct. If the spark plug is worn or damaged, replace before using.
4. Make sure all fasteners are tight.
5. Make sure all guards, shields, and covers are in place.
6. Make sure all adjustments are correct.

TROUBLE SHOOTING CHART

PROBLEM	LOOK FOR	REMEDY
Difficult starting	Defective spark plug.	Replace defective spark plug.
Engine runs erratically	Blocked fuel line.	Clean fuel line.
	Empty gas tank.	Check fuel supply,
	Stale gasoline.	Add fresh gasoline with fuel stabilizer.
	Water or dirt in fuel system.	Remove carburetor bowl to drain fuel tank. Refill with fresh fuel. CAUTION: Do not remove carburetor bowl when the engine is hot.
Engine stalls	Unit running on CHOKE.	Set choke lever to RUN position.
Loss of power	Gas cap vent hole is plugged.	Remove ice and snow from cap. Be sure vent hole is clear.
Excessive vibration	Loose parts or damaged impeller.	Stop engine immediately and remove spark plug wire. Tighten all bolts and make all necessary repairs. If vibration continues, have the unit serviced by a competent repairman.
Unit fails to propel itself	Drive belt loose or damaged.	Replace drive belt. Refer to Drive Belt Replacement in the Maintenance section of this manual.
	Incorrect adjustment of traction drive cable.	Adjust traction drive cable. Refer to Cable Adjustment in the Maintenance section of this manual.
	Worn or damaged friction disc.	Replace friction disc. Refer to Friction Wheel Replacement in the Maintenance section of this manual.
Unit fails to discharge snow	Auger drive belt loose or damaged.	Replace or adjust auger drive belt. Refer to Drive Belt Replacement and Drive Belt Adjustment in the Maintenance section of this manual.
	Auger control cable not adjusted correctly.	Adjust auger control cable. Refer to Cable Adjustment in the Maintenance section of this manual.
	Broken shear bolt.	Replace shear bolt. Refer to Auger Shear Bolt Replacement in the Maintenance section of this manual.
	Discharge chute clogged.	Stop engine immediately and disconnect spark plug wire. Refer to the first Warning in Snow blower Operation in the Operation section of this manual. Clean discharge chute and inside of auger housing.
	Foreign object lodged in auger.	Stop engine immediately and disconnect spark plug wire. Refer to the third Warning in Snow blower Operation in the Operation section of this manual. Remove object from auger.

Identifying Your Snow blower

Your new Snow blower has two (2) identifying numbers: (1) unit model number: (2) unit serial number. The two preceding numbers are required to insure that the proper replacement parts are obtained when required. If you have any questions concerning parts, service, or technical data, contact your nearest John Deere/Frontier dealer.

For complete warranty information refer to the warranty in the Owner's Information section of this manual.

REPLACEMENT PARTS

WE RECOMMEND JOHN DEERE/FRONTIER quality parts and lubricants available at your John Deere/Frontier dealer.

PART NUMBERS MAY CHANGE. When you order replacement parts, use the part numbers listed below and on the following pages. If a part number changes, your John Deere/Frontier dealer will have the latest part number.

WHEN YOU ORDER PARTS, your John Deere/Frontier dealer must have your snowthrower model and serial number and your engine model number. This is the model and serial number that you recorded in the “Owner’s Information” section of this Owner’s Manual.

QUICK REFERENCE PART NUMBERS

The following is a list of replacement parts that you may need for routine service and maintenance. If you do not see the replacement part you need in the following chart, then check the full list of replacement part illustrations following this page.

ITEM	PART NUMBER *
Belt, Drive	MT579932
Belt, Auger	MT585416
Scraper Blade	MT583043E701
Spark Plug	Champion RC12YC

* Part Numbers are subject to change without notice.

FRONTIER MODEL ST1028

FACTORY MODEL 628102x16A ENGINE

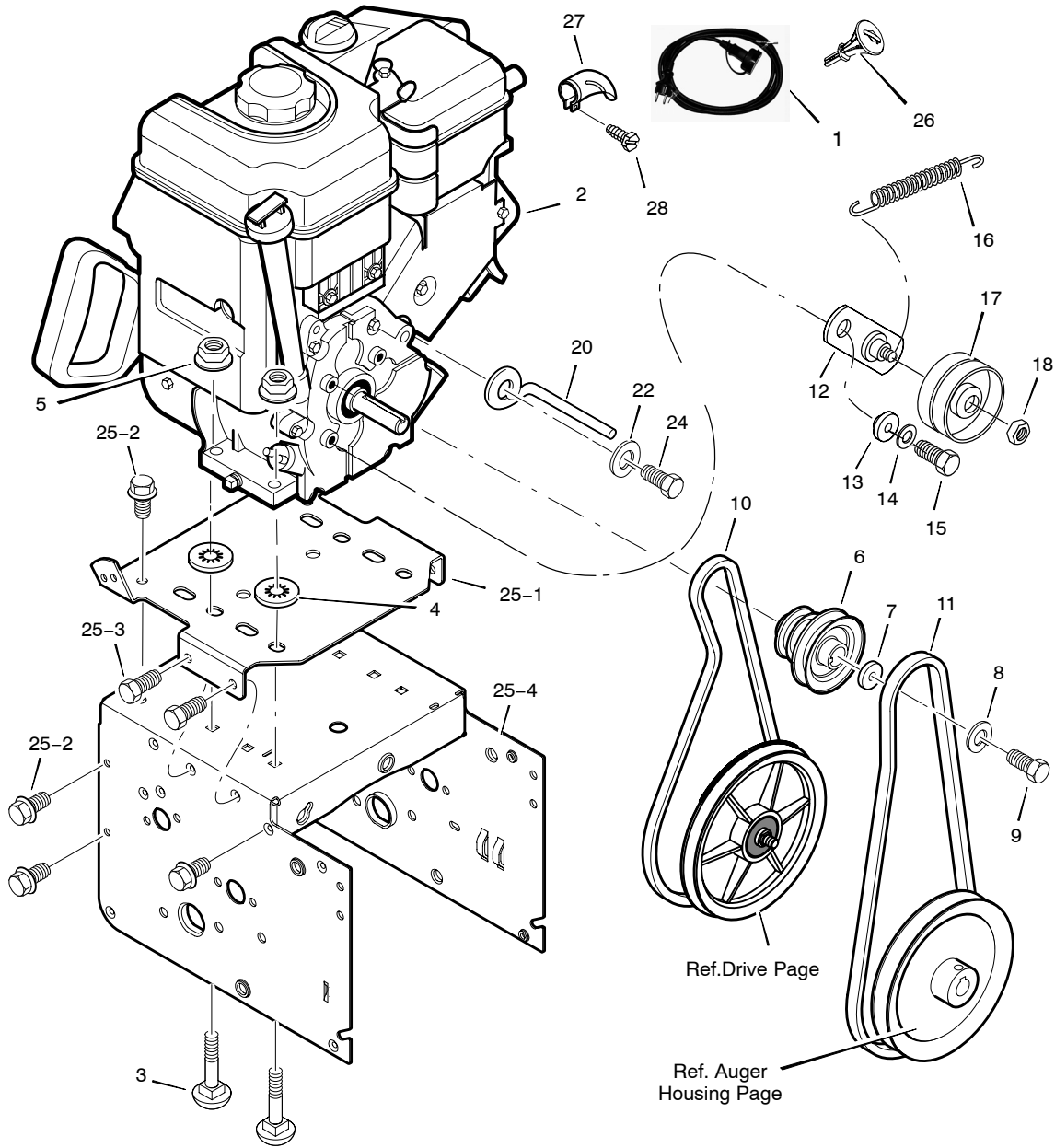

Key No.	Part No.	Description
1	MT6219	CORD, STARTER
2	-----	ENGINE
3	MT002x97	BOLT, CARRIAGE
4	MT028x76	RETAINER, PUSH
5	MT710026	NUT
6	MT1501109	PULLEY, ENGINE
7	MT17x170	WASHER
8	MT71063	WASHER
9	MT71015	SCREW
10	MT579932	BELT, DRIVE V 4L
11	MT585416	BELT, AUGER V 3L
12	MT1501112 YZ	BRACKET ASSEMBLY, IDLER
13	MT1501065	BUSHING, IDLER BRACKET
14	MT71060	WASHER, SPLIT
15	MT710097	SCREW 5/16-24 X .75

Key No.	Part No.	Description
16	MT53704	SPRING, IDLER TRACTION DRIVE
17	MT1502120	PULLEY, IDLER
18	MT590	NUT, JAM 3/8-16
20	MT1501201	GUIDE, ROD BELT
22	MT71060	WASHER
24	MT710097	SCREW
25	-----	FRAME ASSEMBLY
25-1	MT1501062E511	PLATE, ENGINE
25-2	MT310169	SCREW
25-3	MT25x020	SCREW
25-4	MT1501049E511	MOTOR BOX
26	MT1501214	KEY, BRIGGS ENGINE
27	MT226462	DEFLECTOR, MUFFLER
28	MT810140	SCREW
--	MTF-051058L	OWNER'S MANUAL

FRONTIER MODEL ST1028

FACTORY MODEL 628102x16A FRAME

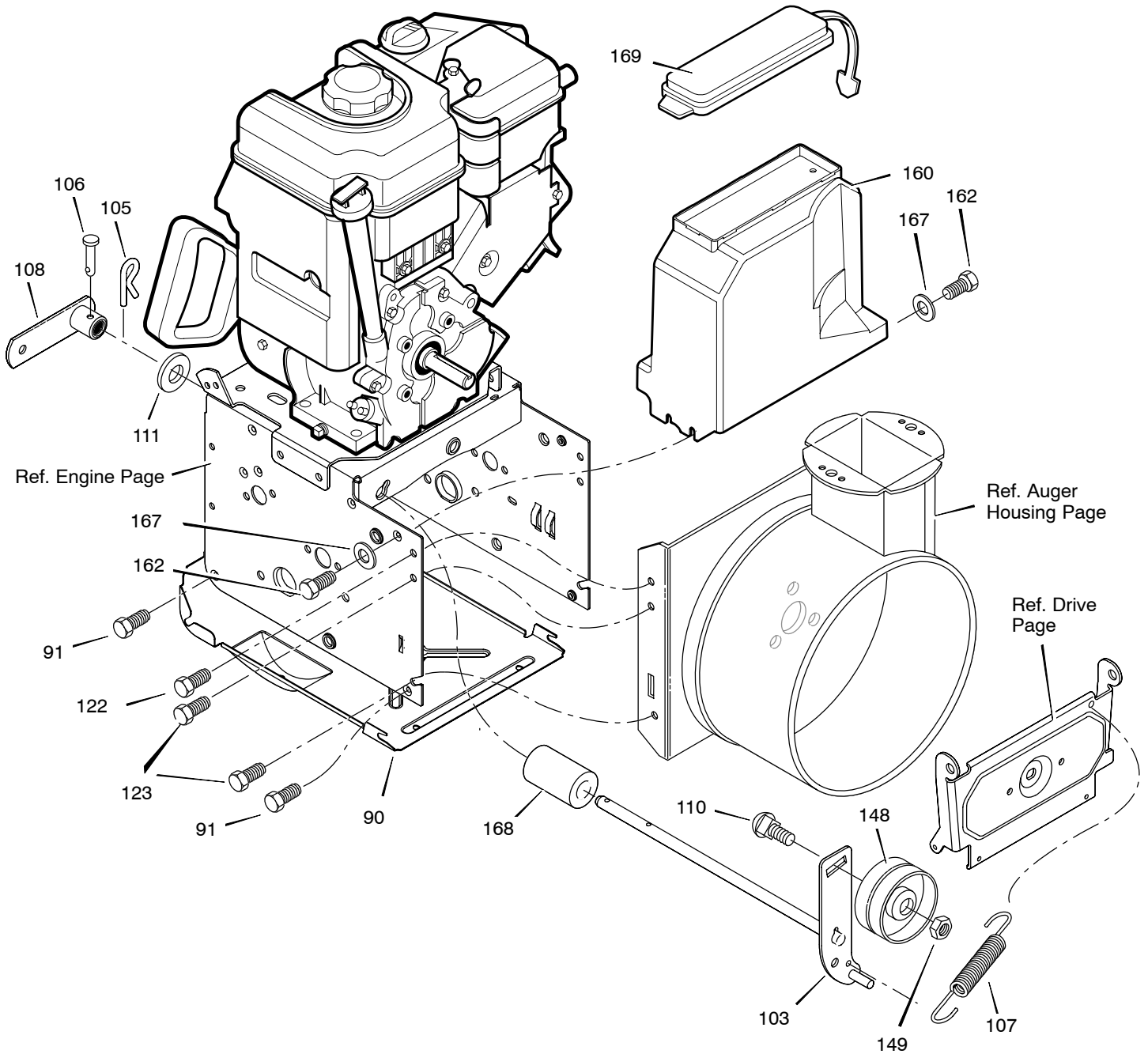

FRONTIER MODEL ST1028

FACTORY MODEL 628102x16A FRAME

Key No.	Part No.	Description
90	MT1501055E701	COVER, BOTTOM
91	MT310169	SCREW, 1/4-20X .63
103	MT1501369 YZ	IDLER ASSEMBLY, AUGER
105	MT711682	PIN, HAIR .38DIA X 1.64LG
106	MT761761	PIN, CLEVIS 3/16" DIA
107	MT165x159	SPRING, TENSION
108	MT761675 YZ	ASSY., SPRING ATTACH
110	MT585781	BOLT, 3/8-16X1.25 CARR.
111	MT711617	WASHER, FLAT
122	MT25x020	SCREW, TAP 5/16-18 X .50
123	MT25x021	SCREW, TAP 5/16-18 X .75
148	MT1502120	PULLEY, IDLER
149	MT590	NUT, JAM 3/8-16
160	MT1502182	COVER, BELT
162	MT26x306	SCREW, TAP
167	MT71067	WASHER, FLAT
168	MT1501200	SPACER, AUGER BRACKET
169	MT760539	LID, TOOL BOX

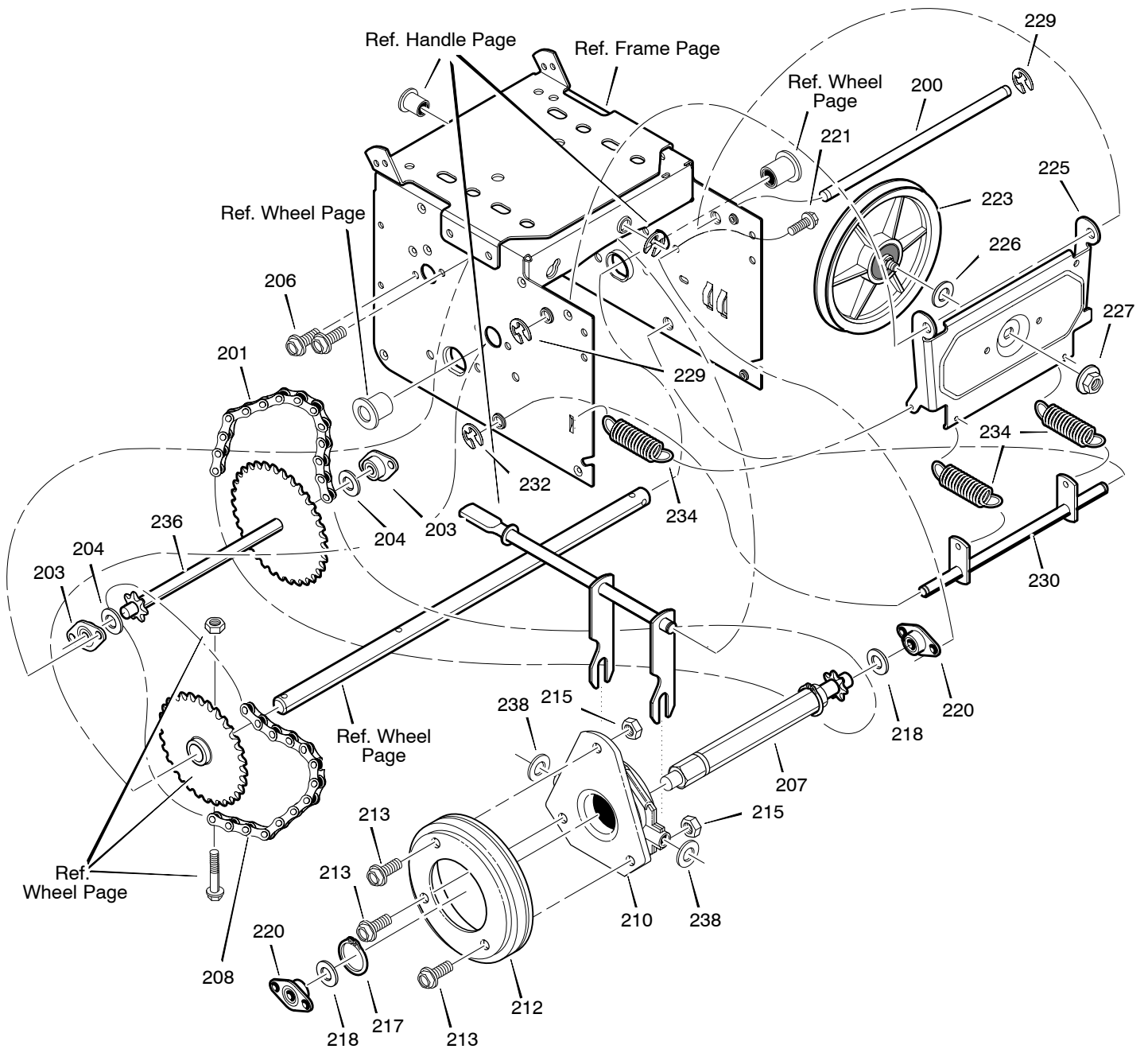

FRONTIER MODEL ST1028

FACTORY MODEL 628102x16A DRIVE

Key No.	Part No.	Description
200	MT1501092 YZ	LF AXLE, SWING PLATE YZ
201	MT579851	CHAIN, ROLLER #420x19.00
203	MT334163	BEARING AND RETAINER, ASSY
204	MT579858	WASHER
206	MT25x020	SCREW, TAP 5/16-18x0.5
207	MT1501100	ASSY, HEX SHAFT
208	MT579868	CHAIN, ROLLER #420x18.00 LG
210	MT337029	BEARING, TRUNION CLUTCH R
212	MT1501435	WHEEL, FRICTION DISC
213	MT001x38	BOLT
215	MT303008	NUT, KEPS HEX 1/4-20
217	MT579859	RING, RETEXT
218	MT579858	WASHER
220	MT334163	BEARING AND RETAINER, ASSY
221	MT25x020	SCREW, TAP 5/16-18 x .5
223	MT1501115	FRICTION PULLY
225	MT1501057 YZ	LF PLATE, SWINGING YZ
226	MT1501158	SPACER, FRICTION PULLEY
227	MT15X114	NUT, FLANGE LOCK 3/8-24
229	MT11X30	RETAINER, RING
230	MT1501107 YZ	LF ASSY, SPRING LINK YZ
232	MT11X30	RETAINER, RING
234	MT165X112	SPRING, EXTENSION
236	MT1501090	SPROCKET 33/7
238	MT71074	WASHER, FLAT

FRONTIER MODEL ST1028

FACTORY MODEL 628102x16A AUGER HOUSING

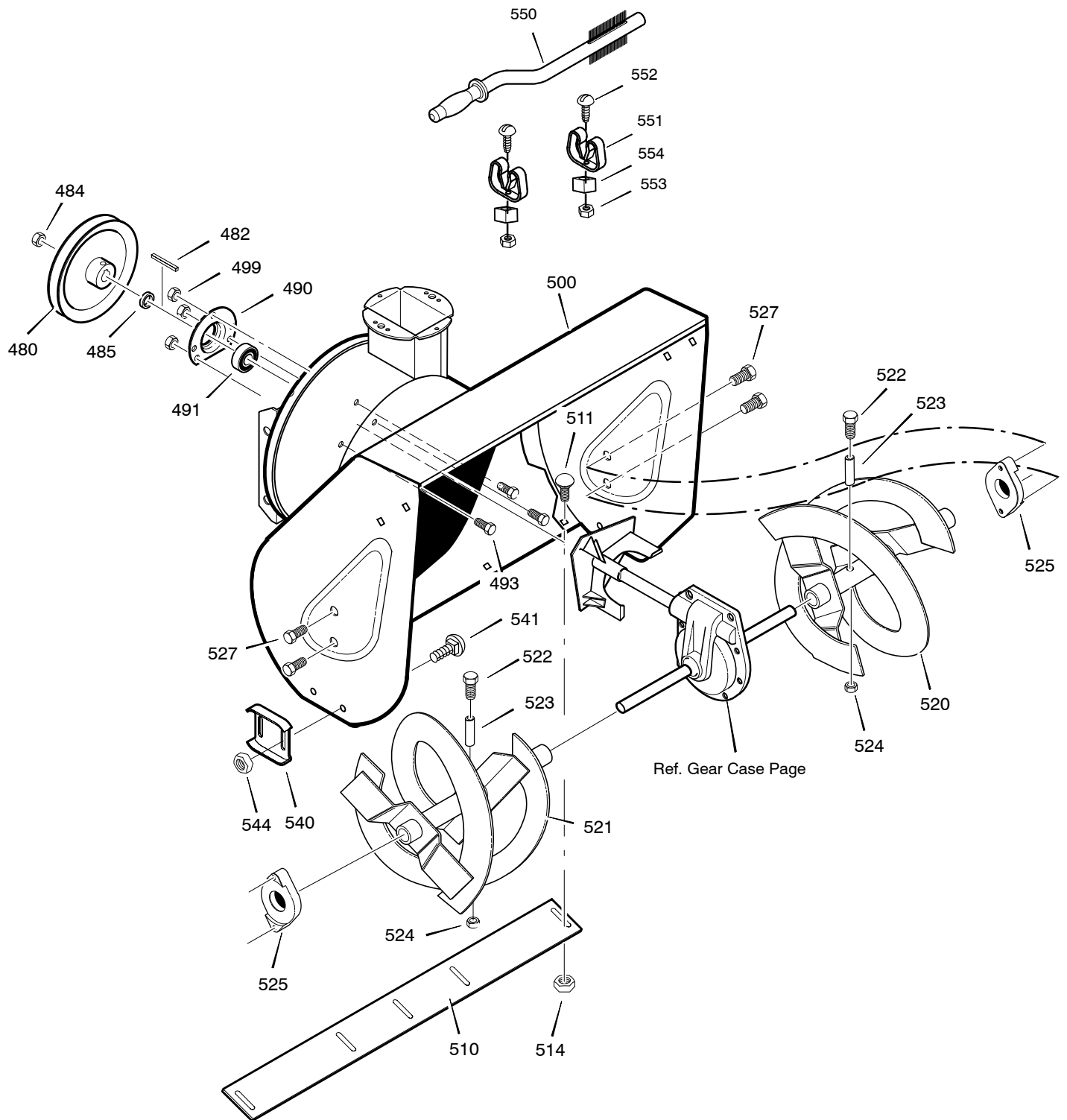

FRONTIER MODEL ST1028

FACTORY MODEL 628102x16A AUGER HOUSING

Key No.	Part No.	Description
480	MT583146	PULLEY, 4L 8.40 OD
482	MT2001022	KEY, SQUARE 3/16 X 3/4
484	MT15x112	NUT, 1/2-20
485	MT1501158	SPACER, FRICTION PULLEY
490	MT582957 YZ	RETAINER, BALL BRNG
491	MT1501389	BEARING, BALL
493	MT001X92	BOLT, HEX 5/16-18X .50
499	MT710026	NUT, 5/16-18 HEXWDFLLK
500	MT1501590E511	HOUSING, ASSY
510	MT583043E701	BLADE, SCRAPER
511	MT001x45	BOLT, 5/16-18x.62
514	MT710026	NUT, 5/16-18
520	MT760597E701	AUGER, ASSY, LH
521	MT760598E701	AUGER, ASSY, RH
522	MT9524	SCREW, 1/4-20 X 1.75
523	MT3943	SPACER, SLEEVE
524	MT73826	NUT, 1/4-20
525	MT53757	BEARING, FLANGE
527	MT25x201	SCREW, 5/16-18X .75
540	MT1502187E701	SKID, HEIGHT ADJUST
541	MT908156	BOLT, 5/16-18 X .50
544	MT710026	NUT, 5/16-18
550	MT1501576	BRUSH, CLEANOUT
551	MT1501672	CLIP, RETAINER
552	MT06x115	SCREW
553	MT15x146	NUT
554	MT578063	BLOCK
--	MT1501216	KIT, SHEAR BOLT

FRONTIER MODEL ST1028

FACTORY MODEL 628102x16A GEAR CASE

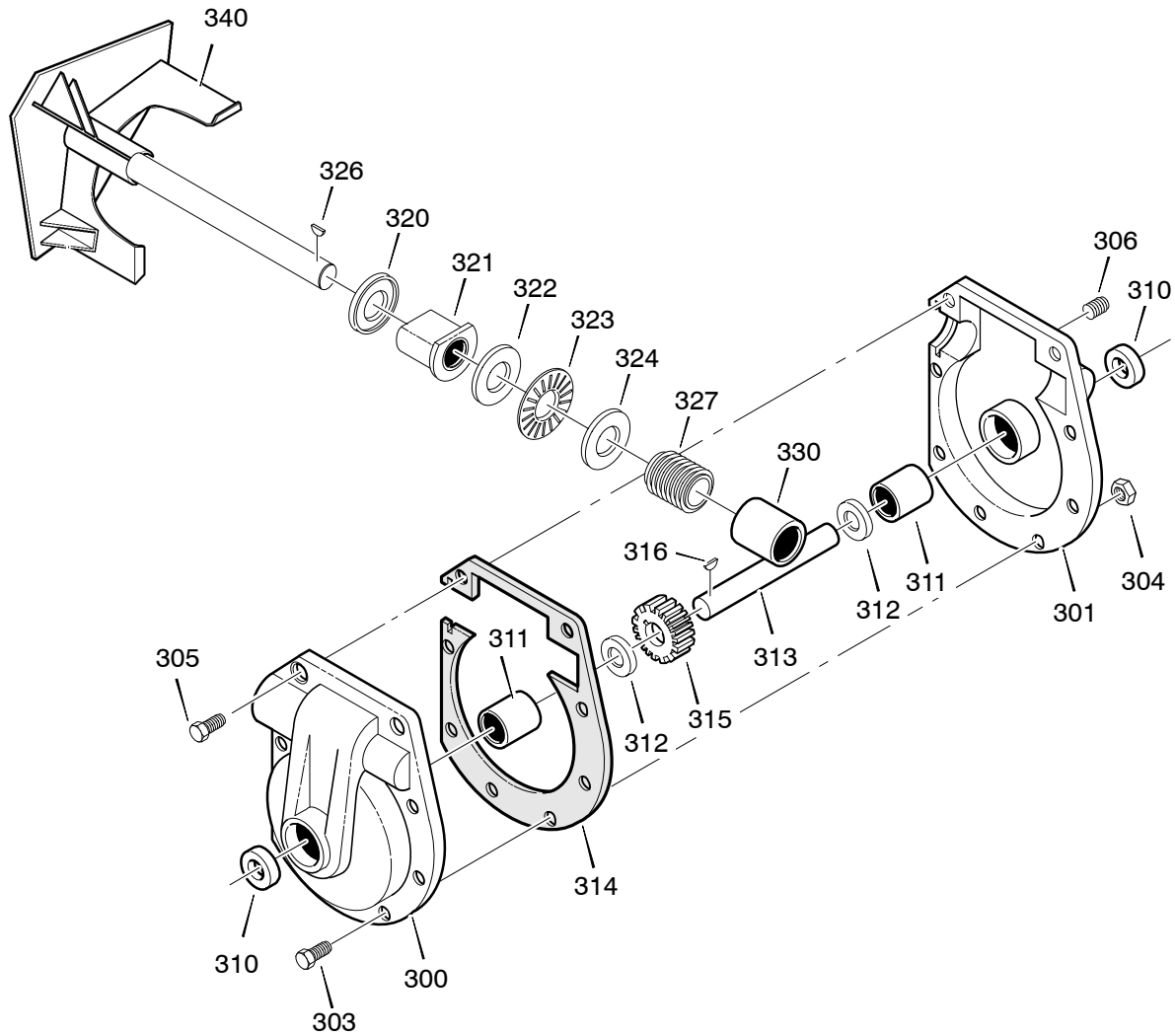

Key No.	Part No.	Description	Key No.	Part No.	Description
300	MT896	CASE, GEAR, RH	316	MT73905	KEY, WOODRUFF #91
301	MT895	CASE, GEAR, LH	320	MT53737	RING, QUAD 0.924 ID
303	MT910828	SCREW, 5/16-24 x 1.00	321	MT583126	BEARING, FLANGE
304	MT71100	NUT, 5/16-24	322	MT48275	WASHER, FLAT
305	MT330434	SCREW, 5/16-24 x 1.50	323	MT50684	BEARING, ROLLER
306	MT53749	PLUG, PIPE 0.25-18	324	MT48275	WASHER, FLAT
310	MT780151	SEAL, OIL	326	MT50795	KEY
311	MT53743	BEARING, SLEEVE	327	MT53732	WORM
312	MT53748	WASHER, FLAT	330	MT53731	BEARING, SLEEVE
313	MT584515	SHAFT, AUGER OUTPUT	340	MT1501147E701	IMPELLER
314	MT897	GASKET, GEAR BOX	--	MT333431	10oz TUBE LUBRIPLATE
315	MT53730	WORM GEAR			

FRONTIER MODEL ST1028

FACTORY MODEL 628102x16A REMOTE CONTROL

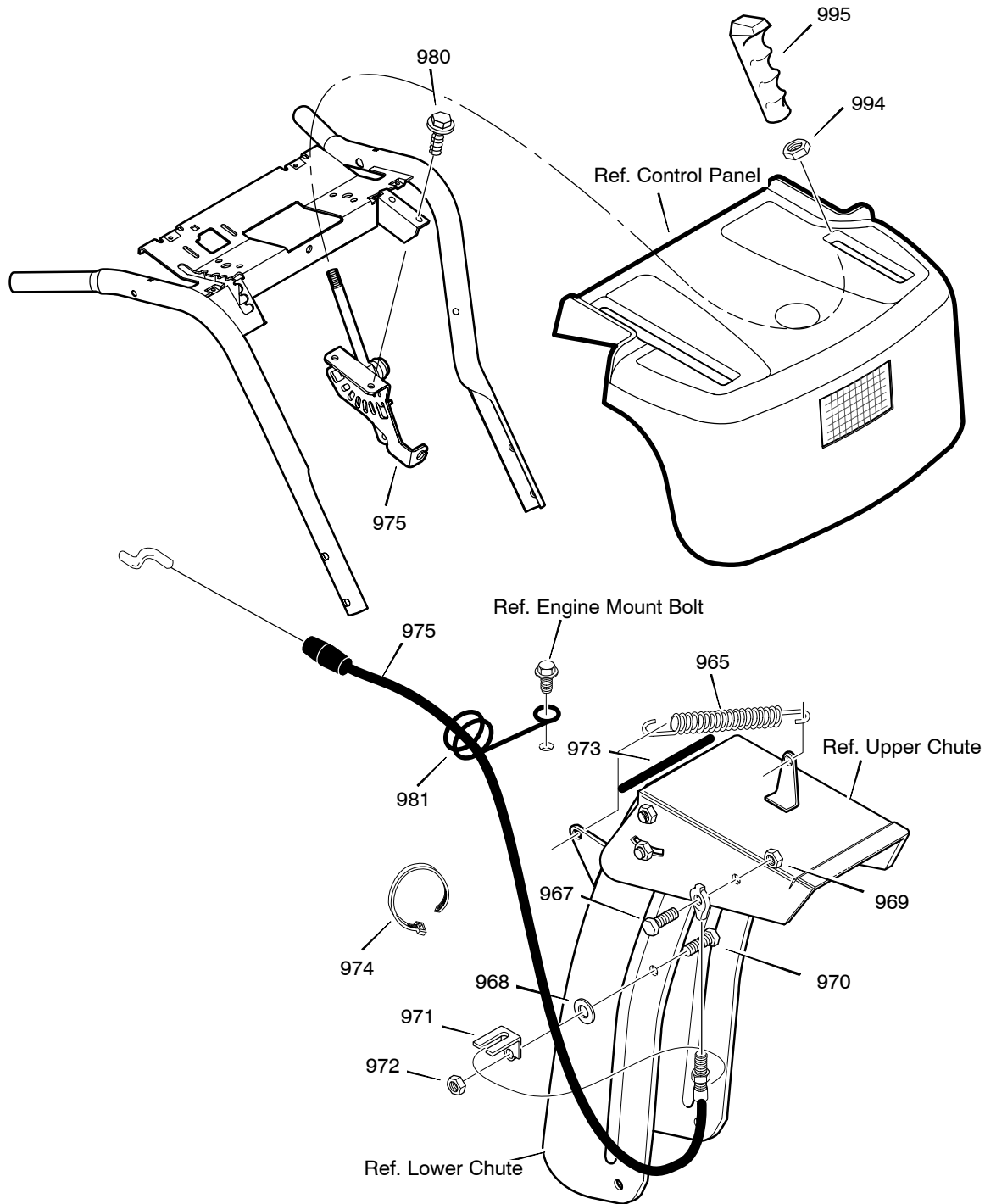

Key No.	Part No.	Description
965	MT318468	TENSION SPRING
967	MT310088	BOLT, SHOULDER
968	MT73787	FLATWASHER
969	MT15x143	NUT
970	MT313676	SCREW, 5/16-18 X 0.75
971	MT306447 YZ	BRACKET, CABLE CHUTE
972	MT71391	NUT, 5/16-18

Key No.	Part No.	Description
973	MT1001221	TRIM STRIP, BLACK
974	MT071372	TIE, CABLE
975	MT1501393	CABLE, CHUTE DEFLECTOR
980	MT313676	SCREW
981	MT780220	WIRE FORM, CHUTE CABLE
994	MT71045	NUT, 3/8-16
995	MT306689	KNOB, SHIFT

FRONTIER MODEL ST1028

FACTORY MODEL 628102x16A DISCHARGE CHUTE

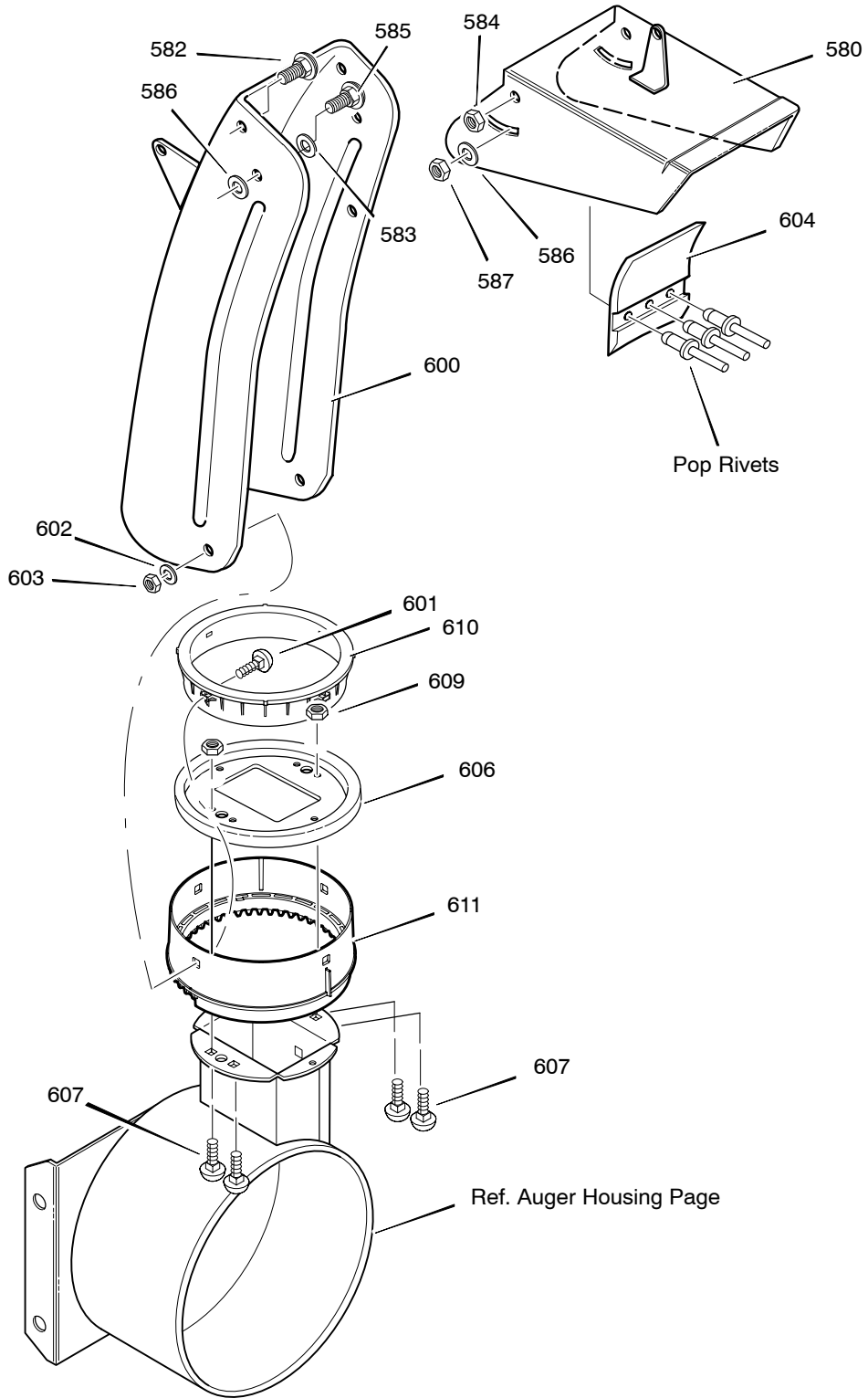

FRONTIER MODEL ST1028

FACTORY MODEL 628102x16A DISCHARGE CHUTE

Key No.	Part No.	Description
580	MT761168E701	CHUTE, UPPER W/REMOTE
582	MT578088	SCREW, 5/16-18 X.75
583	MT12021	PLASTIC WASHER
584	MT71038	NUT
585	MT578088	SCREW, 5/16-18 X.75
586	MT6711	PLASTIC WASHER
587	MT71038	NUT
600	MT761169E701	CHUTE, LOWER W/REMOTE
601	MT2x100	BOLT
602	MT71071	WASHER, FLAT
603	MT71038	NUT
604	MT762322	FLAP
606	MT1501932 YZ	CHUTE COLLAR
607	MT02x101	BOLT
609	MT15x145	NUT
610	MT337227	RETAINER, RING INNER
611	MT1501282	RETAINER, RING OUTER

FRONTIER MODEL ST1028

FACTORY MODEL 628102x16A HANDLE

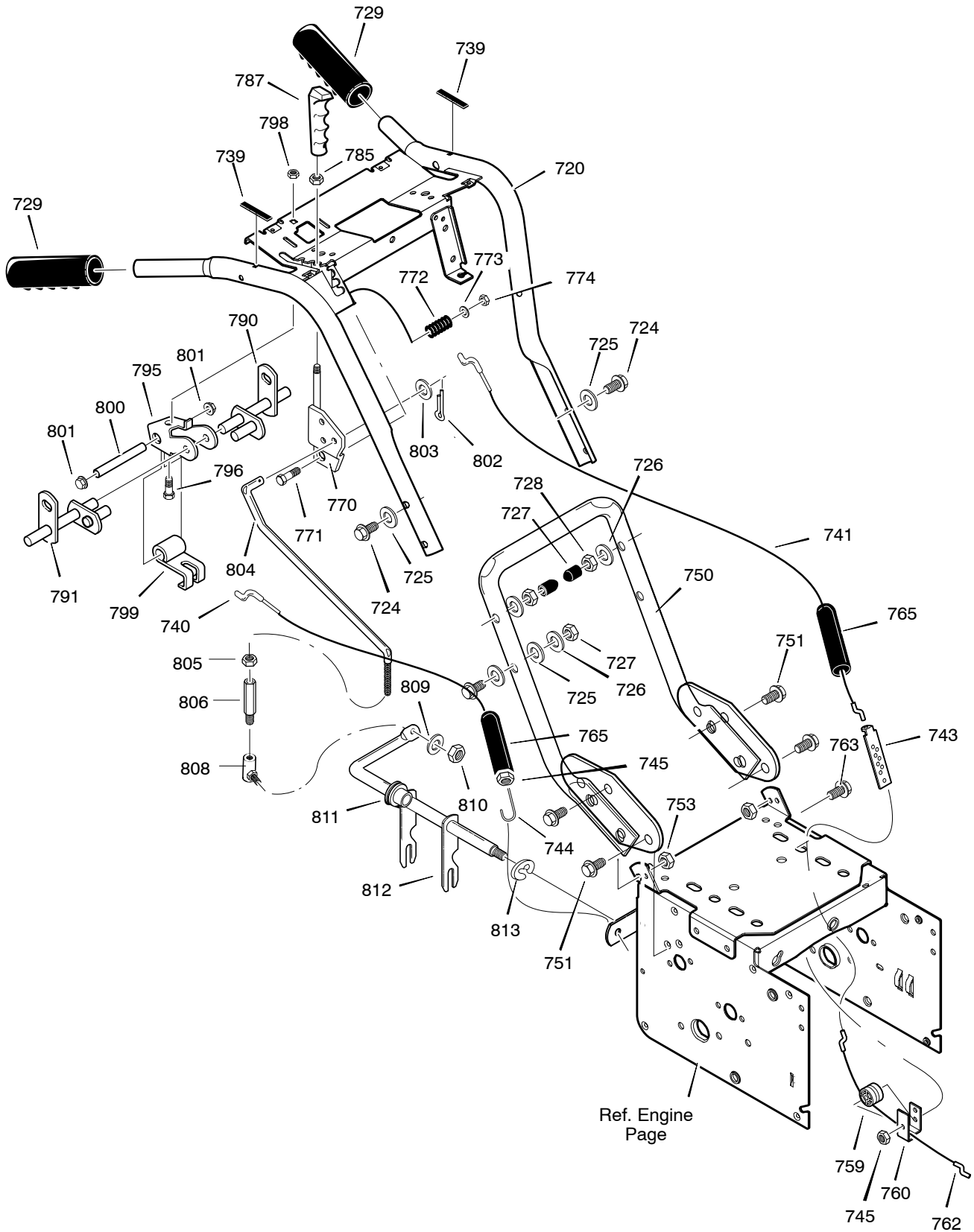

FRONTIER MODEL ST1028

FACTORY MODEL 628102x16A HANDLE

Key No.	Part No.	Description	Key No.	Part No.	Description
720	MT1501421E701	ASSY, HANDLE	773	MT71072	WASHER, FLAT
724	MT7288	SCREW	774	MT71046	NUT, HEX
725	MT71072	WASHER, FLAT	785	MT71045	NUT, HEX
726	MT71062	WASHER	787	MT306689	KNOB, SHIFT
727	MT71044	NUT	790	MT578926	ROD, ASSY LH
728	MT7289	STOP, PLASTIC	791	MT578924	ROD, ASSY RH
729	MT337399	GRIP, HANDLE	795	MT579002	BRACKET, CAM
739	MT4049	BUMPER	796	MT002x53	SCREW
740	MT1501451	CABLE, AUGER CLUTCH	798	MT71038	NUT, NYLOCK
741	MT1501452	CABLE, DRIVE	799	MT8417	CAM LOCK
743	MT313441	BRKT, CABLE ADJ	800	MT584673	PIN, SPRING PIVOT
744	MT1673	SPRING, CLUTCH	801	MT73664	NUT, PUSH ON
745	MT15x145	NUT, HEX	802	MT71081	PIN, COTTER
750	MT1501449E701	HANDLE, LOWER	803	MT71071	FLATWASHER
751	MT25x021	SCREW	804	MT1501728	ROD, SPEED CONTROL
759	MT579860	SPOOL, CABLE	805	MT71042	NUT, 5/16-18
760	MT1501059 YZ	BRKT, SPOOL	806	MT6352	ADAPTER, ROD
762	MT1501122	CABLE, LOWER DRIVE	808	MT50782	BALLJOINT, STEEL
763	MT001798	BOLT, HEX 1/4-20 x 1.5	809	MT71060	WASHER
765	MT308146	BOOT, CABLE	810	MT71042	NUT, 5/16-18
770	MT1501570 YZ	BRACKET, SHIFT	811	MT579944	BEARING, FL
771	MT4058	SCREW	812	MT1501110 YZ	ROD, YOKE
772	MT50786	SPRING	813	MT11X30	RETAINER, RING

FRONTIER MODEL ST1028

FACTORY MODEL 628102x16A

CHUTE ROD / GOULOTTE TIGE

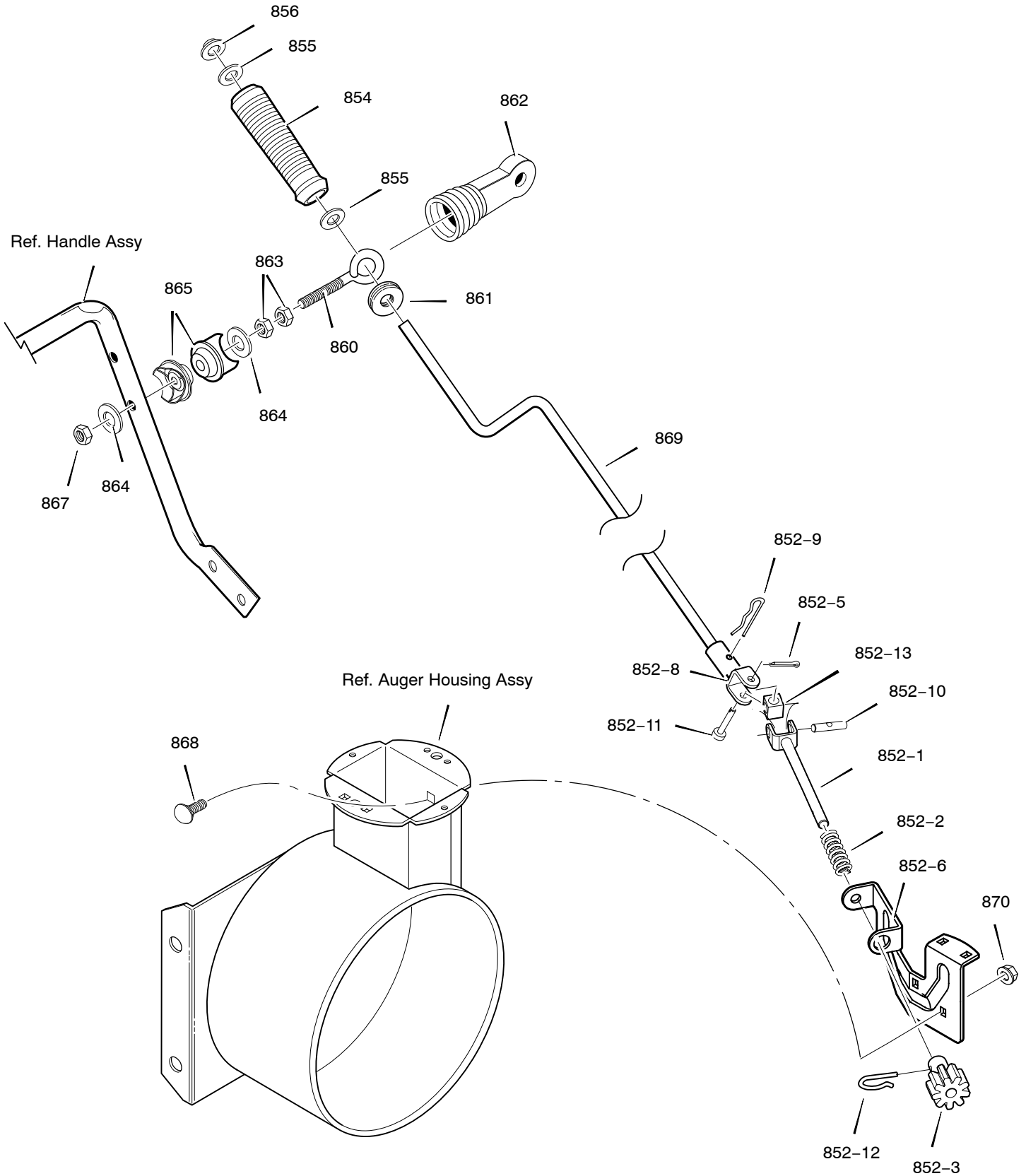

FRONTIER MODEL ST1028

FACTORY MODEL 628102x16A CHUTE ROD

Key No.	Part No.	Description
852-1	MT1501533 YZ	ASSEMBLY, YOKE & ROD
852-2	MT164x37	SPRING
852-3	MT1501067	GEAR, CHUTE ROTATION 9T
852-5	MT579493	PIN, COTTER
852-6	MT1501306E701	BRACKET, CHUTE GEAR
852-7	MT1501293	PIN, HAIR
852-8	MT1501075 YZ	ASSEMBLY, YOKE ADAPTER YZ
852-9	MT711682	PIN, HAIR
852-10	MT578060	PIN, UNIVERSAL JOINT
852-11	MT578309	PIN, CLEVIS
852-13	MT578063	HOUSING, UNIVERSAL
854	MT307399	KNOB, SLEEVE
855	MT309312	FLATWASHER
856	MT73664	NUT, PUSH ON 3/8"
860	MT1501456	EYE BOLT 3/8-16X6.50
861	MT148	GROMMET, EYE BOLT
862	MT1501457	BOOT, EYE BOLT
863	MT71045	NUT, 3/8-16 HEXJAM
864	MT71072	FLATWASHER .406X.81X.066
865	MT309344	ADAPTER, BOOT
867	MT71046	NUT, 3/8-16 HEXNYL
868	MT02x101	BOLT, CARRIAGE 1/4-20 X 0.75
869	MT15x145	NUT, 1/4-20
870	MT1501074 YZ	CRANK, ASSY CHUTE

FRONTIER MODEL ST1028

FACTORY MODEL 628102x16A HEADLIGHT

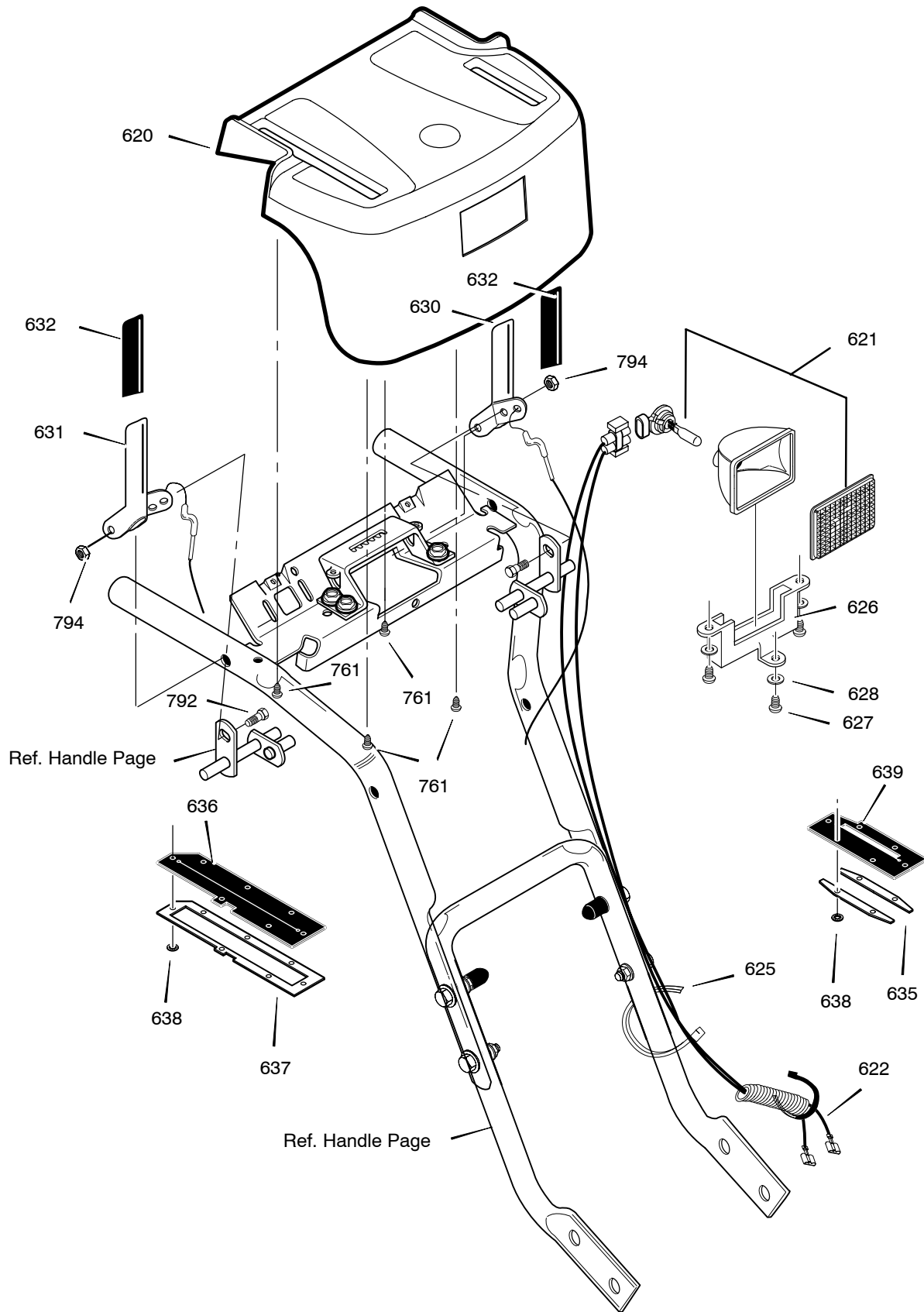

FRONTIER MODEL ST1028

FACTORY MODEL 628102x16A CONTROL PANEL

Key No.	Part No.	Description
620	MT1501988	PANEL, CONTROL W/LIGHT
621	MT762343	LIGHT, HALOGEN
622	MT1501455	HARNESS, WIRE
625	MT071372	TIE, CABLE
626	MT1501412	BRACKET, LIGHT
627	MT901696	SCREW #8 X .50
628	MT901736	WASHER, FLAT
630	MT1501358E701	CLUTCH HANDLE LH
631	MT1501357E701	CLUTCH HANDLE RH
632	MT337380	GRIP, CLUTCH LEVER
635	MT1501545	FRAME, COVER
636	MT1501542	COVER, SPEED LEVER
637	MT1501544	FRAME, SPEED COVER
638	MT028x79	NUT, PUSH
639	MT1501543	COVER, CHUTE LEVER
792	MT905531	BOLT, 1/4-20 X 0.50
794	MT908913	NUT, 1/4-20

FRONTIER MODEL ST1028

FACTORY MODEL 628102x16A WHEELS

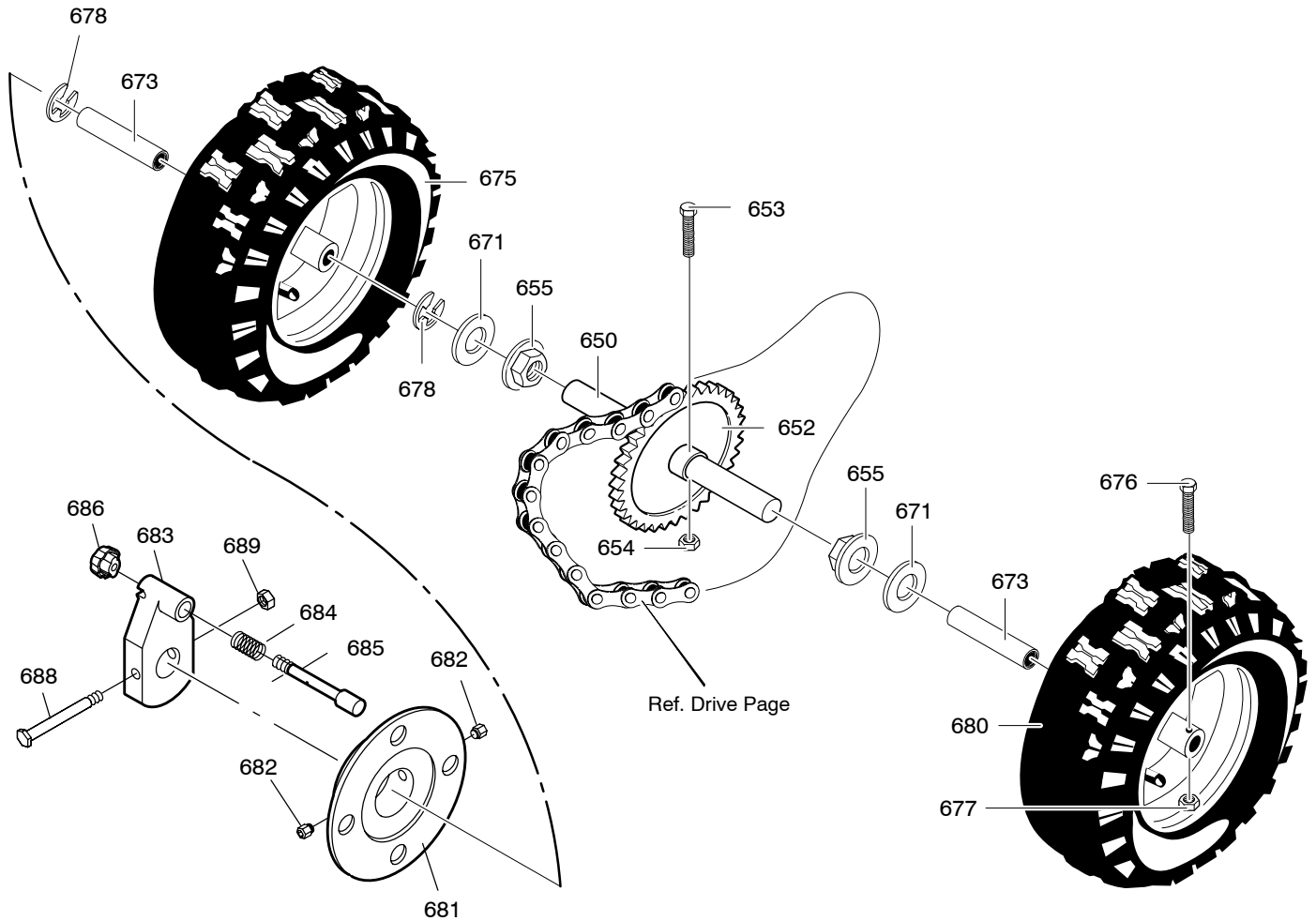

Key No.	Part No.	Description	Key No.	Part No.	Description
650	MT1501563	SHAFT, AXLE	678	MT239	RING, RET
652	MT1501089	SPRKT & HUB	680	MT1501825	TIRE & RIM, LEFT
653	MT01x193	SCREW, 1/4-20X1.75	681	MT1501032E	DISC, WHEEL
654	MT15x145	NUT, 1/4-20 HEX NYLOCK	682	MT2001066	SCREW
655	MT1501114	BEARING, AXLE	683	MT1501930	HUB ASSEMBLY, WHEEL LOCK
671	MT017x83	FLATWASHER	684	MT164x34	SPRING, COMPRESSION *
673	MT1501138	BUSHING, WHEEL	685	MT1501856 YZ	PIN, LOCK *
675	MT1501824	TIRE & RIM, RIGHT	686	MT1501855	KNOB *
676	MT577015	SCREW, 1/4-20X1.75	688	MT73839	SCREW
677	MT15x145	NUT, 1/4-20 HEX NYLOCK	689	MT15x116	NUT

* These parts are included with key 683. They are not compatible with model year 2003 machines. Order new Hub, Wheel Lock for upgrade.

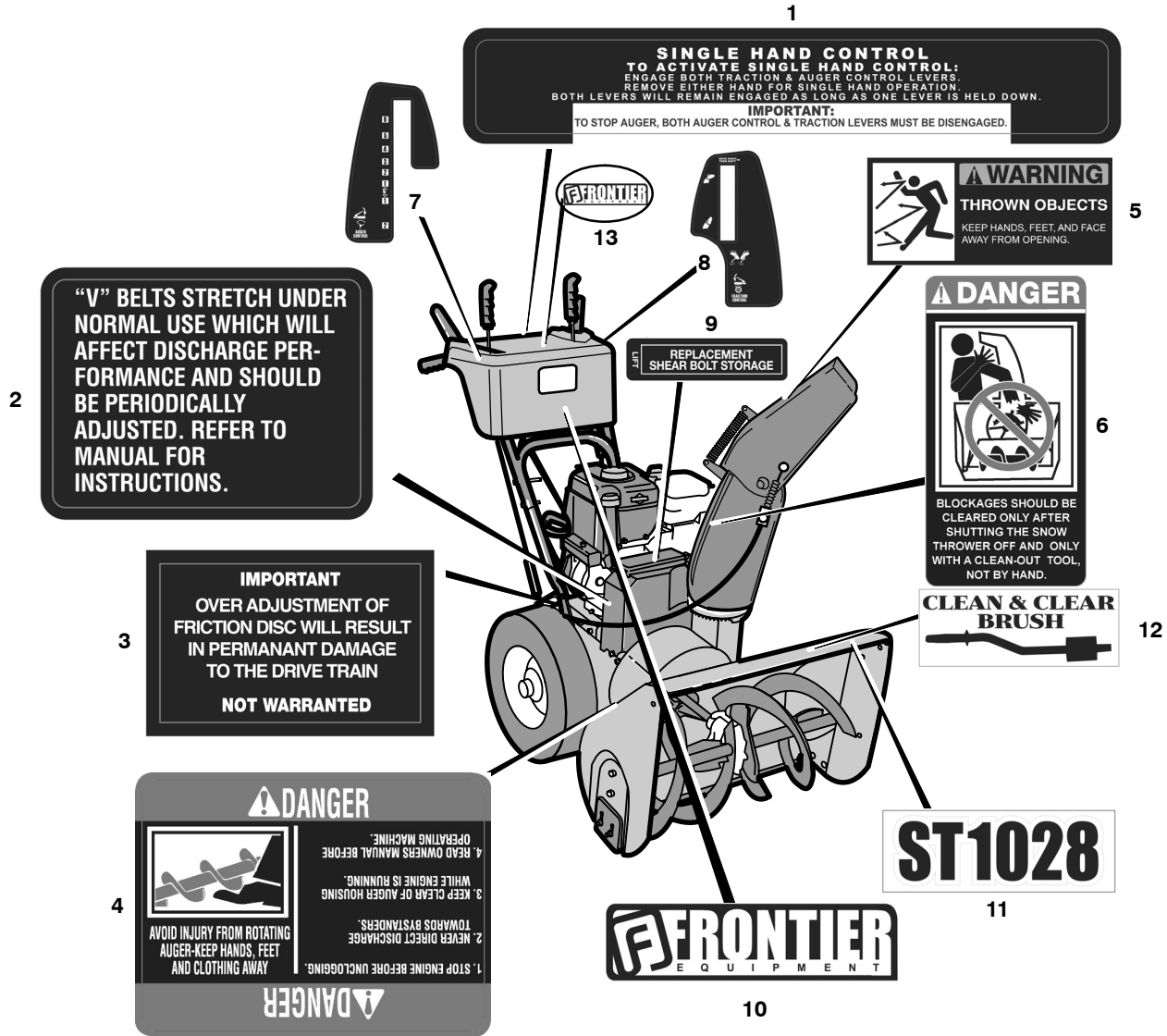

Key No.	Part No.	Description
1	MT48x5294	DECAL, SINGLE HAND CONTROL
2	MT7390	DECAL, V-BELTS
3	MT7859	DECAL, OVER ADJUSTMENT
4	MT48x5286	DECAL, ROTATING AUGER
5	MT48x5578	DECAL, DANGER
6	MT48x5965	DECAL, UNCLOGGING CHUTE
7	MT48x5291	DECAL, SPEED CONTROL
8	MT48x5967	DECAL, REMOTE CHUTE CONTROL
9	MT760983	DECAL, SHEAR BOLTS
10	MT1501548	LOGO NAMEPLATE, FRONTIER
11	MT48x5296	DECAL, ST1028
12	MT48x5599	DECAL, CLEAN & CLEAR BRUSH
13	MT48x5604	DECAL, PANEL
---	MTF-051058L	OPERATOR'S MANUAL

SPECIFICATIONS ST1028

Engine	Briggs & Stratton Intek Snow OHV
Horsepower	10.5 hp
Starter	Electric / Recoil
Fuel Capacity	4 quarts
Drive System	Friction Disc
Speeds	6 Forward / 2 Reverse
Tire Diameter	16"
Traction Control	Wheel Lock
Clearing Width	28"
Housing Height	21"
Auger Diameter	12"
Auger Type	Steel / Saw Tooth
Impeller Diameter	12"
Chute Rotation	Remote
Chute Turning Radius	190°
Deflector Control	Remote
Weight	271 lbs
Warranty - Engine	3 years
Warranty - Machine	3 years

